MX type roof extract fan



instructions for use

Vent-Axia[®]

Table of Contents

1. Foreword	page 3	11. Malfunctions	
2. Guarantee and liability		11.1 Malfunction tables	page 22-24
2.1 Guarantee conditions	page 3	11.2 Replacement of components	page 25
2.2 Liability	page 3	11.3 Logbook	page 26
3. Safety		12. EC declaration of conformity	page 27
3.1 General safety regulations	page 4		
3.2 Pictograms used	page 4		
4. Technical data			
4.1 General specifications	page 5		
4.2 Dimensioned drawings	page 6		
5. Speed control			
5.1 MX without speed control	page 7		
5.2 Speed control of one MX fan	page 7		
5.3 Speed control of a number of MX fans	page 7		
5.4 RSC servo contact	page 7		
5.5 LTG temperature control	page 7		
6. Communication			
6.1 Reading and adjustment	page 8		
6.2 VU Control Unit	page 8		
6.3 Communication with laptop/PC	page 8		
6.4 MX network	page 8		
7. Installation			
7.1 Installation conditions	page 9		
7.2 Transport, storage and unpacking	page 9		
7.3 Verification of delivery	page 9		
7.4 Installation	page 9		
8. Electrical connection			
8.1 Controls clamp strip	page 10		
8.2 Wiring upon delivery	page 10		
8.3 Relationship between speed and voltage at 0-10 V controls input	page 11		
8.4 Wiring diagrams	page 12-16		
9. Adjustment			
9.1 Summary of MX settings	page 17		
9.2 MX network: addressing, settings and copying of settings	page 18		
9.3 Control of air volume	page 19		
9.4 Measuring report	page 20		
10. Inspection and maintenance			
10.1 Inspection and maintenance	page 21-22		

1. Foreword / 2. Guarantee and liability

This installation manual contains instructions for the installation and maintenance of the MX roof extract fan. This manual applies to the following types:

MX 10/10
MX 20/20
MX 30/10
MX 30/20

Read this manual carefully before commencing installation or maintenance of the fan.

This manual contains information required for safe and optimal installation of the MX roof extract fan. It is also intended as a reference for service and maintenance work, in order that this can be carried out in a sound manner.

2.1 Guarantee conditions

Applicable only to products installed and used in the United Kingdom. For details of guarantee outside the United Kingdom contact your local supplier.

Vent-Axia guarantees its products for two years from the date of purchase against faulty material or workmanship. In the event of any part being found to be defective, the product will be repaired, or at the Company's option replaced, without charge, provided that the product:

- 1) has been installed and used in accordance with the instructions given with each unit.
- 2) has not been connected to an unsuitable electricity supply. (The correct electricity supply voltage is shown on the product rating label attached to the unit.)
- 3) has not been subjected to misuse, neglect or damage.
- 4) has not been modified or repaired by any person not authorised by the company.

IF CLAIMING UNDER TERMS OF GUARANTEE

please return the complete product, carriage paid to your original supplier or nearest Vent-Axia Centre, by carrier or personal visit. Please ensure that it is adequately packed and accompanied by a letter clearly marked 'Guarantee Claim' stating the nature of the fault and providing evidence of date and source of purchase.

The guarantee is offered to you as an extra benefit, and does not affect your legal rights.

2.2 Liability

The MX has been designed for extraction of (polluted) air, which is diagonally exhausted. Any other application is seen as 'inappropriate use' and can result in damage to the MX or personal injury, for which the manufacturer cannot be held liable.



Work to be carried out on the fan may only be carried out by a qualified mechanical electrical engineer.

The manufacturer is not responsible for any damage derived from:

- non compliance with the safety, operating and maintenance instructions in this guide;
- the use of components not supplied by the manufacturer;
- normal wear and tear.

Safety

It is important that you heed the safety instructions given below, for sensible use of the MX roof extract fan but also for your own safety and that of other people.

3. Safety

3.1 General safety regulations

- Always comply with the safety regulations and instructions given in this manual.
- Make sure that (parts of) the fan not (yet) anchored and tools cannot fall off the roof and cause damage or personal injury.
- When the fan is completely or partly dismantled, make sure nobody can touch rotating or live parts.
- Do not leave a (partly) dismantled fan which is connected to the power supply, unattended.
- Make sure that parts which conduct electricity do not become wet.
- The fan must be fitted in such a manner that there is no risk of anybody touching the side of the fan which does not have a protective screen (see EN 294).

3.2 Pictograms used

The following pictograms may be used in the manual.



Point of attention

4. Technical data

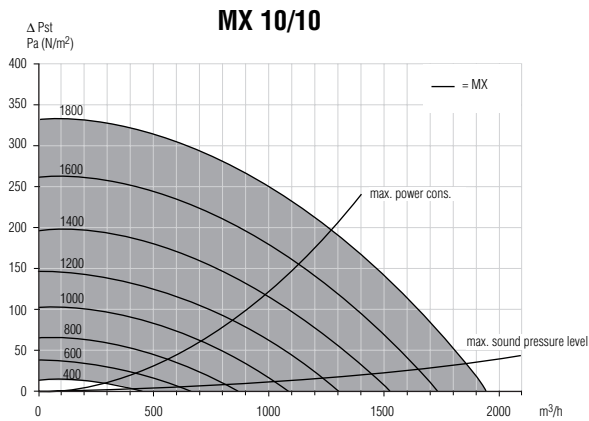

Speed rpm	Current consumption A	Power consumption W_{el}	Noise level			
			deliv dB(A)	suction dB(A)	suction* cos. dB(A)	ϕ
1800	0,76	174	57	72	63	0,99
1600	0,55	125	54	70	61	0,99
1400	0,39	87	50	66	58	0,99
1200	0,26	60	46	63	55	0,99
1000	0,17	39	41	58	51	0,99
800	0,12	27	36	56	49	0,98
600	0,09	19	30	49	42	0,92
400	0,07	12	24	41	35	0,75

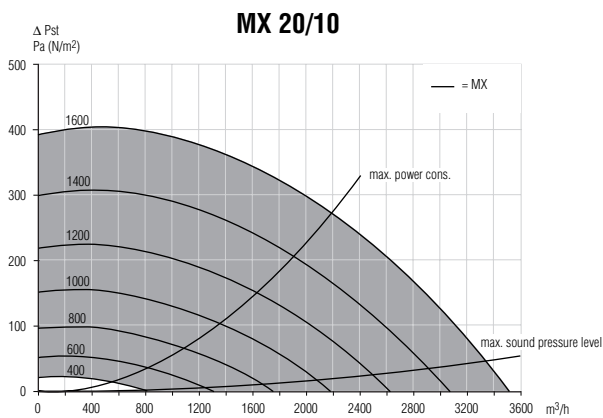

Speed rpm	Current consumption A	Power consumption W_{el}	Noise level			
			deliv dB(A)	suction dB(A)	suction* cos. dB(A)	ϕ
1600	1,80	409	62	77	64	0,99
1400	1,16	266	58	74	62	0,99
1200	0,73	169	53	69	57	0,99
1000	0,44	100	48	65	54	0,99
800	0,25	57	42	59	49	0,99
600	0,14	31	36	55	45	0,96
400	0,09	17	28	48	39	0,82

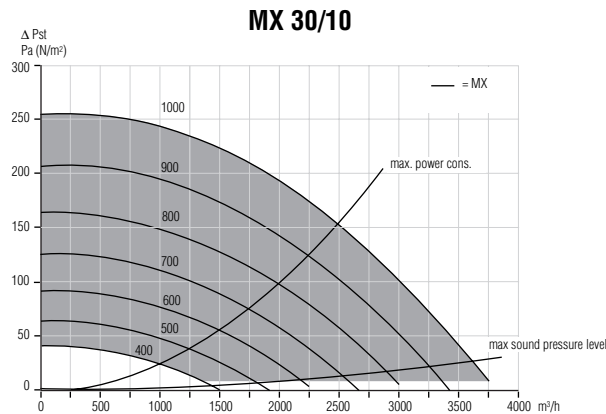

Speed rpm	Current consumption A	Power consumption W_{el}	Noise level			
			deliv dB(A)	suction dB(A)	suction* cos. dB(A)	ϕ
1000	1,30	297	56	71	61	0,99
900	0,92	217	52	68	57	0,99
800	0,64	148	49	65	56	0,99
700	0,44	103	46	62	53	0,99
600	0,29	67	42	60	50	0,99
500	0,19	44	37	55	46	0,99
400	0,13	28	33	52	43	0,94

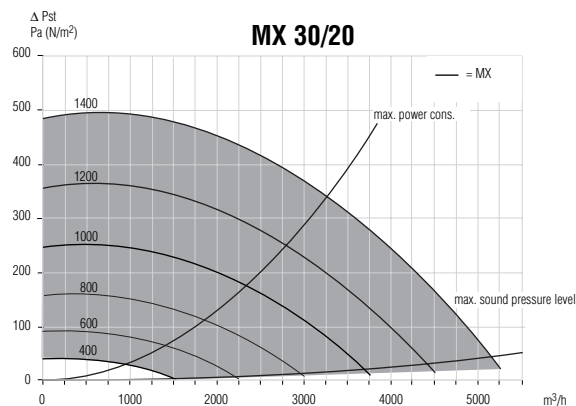

Speed rpm	Current consumption A	Power consumption W_{el}	Noise level			
			deliv dB(A)	suction dB(A)	suction* cos. dB(A)	ϕ
1400	3,34	761	64	78	67	0,99
1200	2,03	462	61	75	64	0,99
1000	1,18	269	57	71	60	0,99
800	0,65	147	51	66	55	0,98
600	0,32	72	44	60	49	0,98
400	0,12	28	36	51	41	0,98

4. Technical data

4.2 Dimensioned drawings

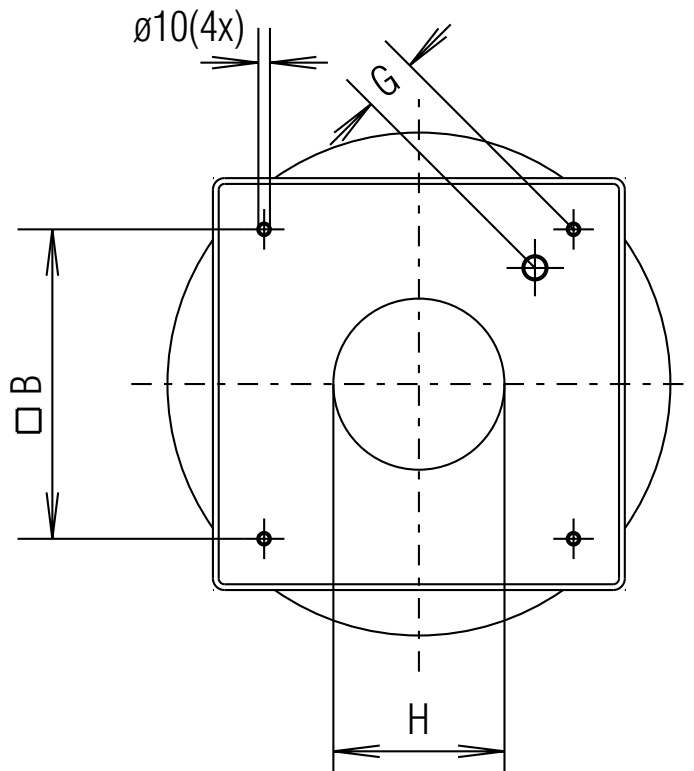
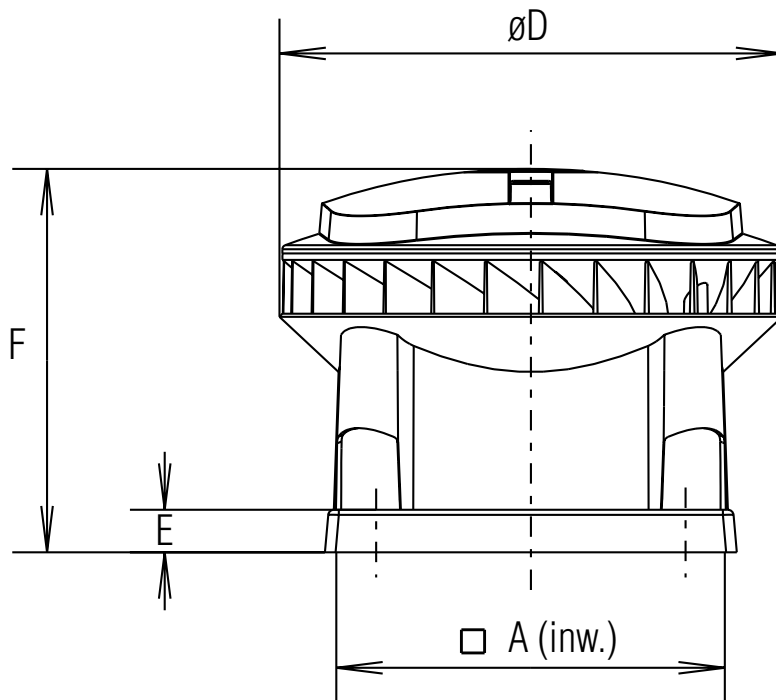

type of fan	type of acc*	A	B	D	E	F	G	H
MX 10	330	460	330	575	60	473	44	196
MX 20	450	580	450	708	60	540	48	241
MX 30	535	665	535	863	60	601	64	302

* The coding indicates the gauge of the fastening holes.

5. Speed control

Various regulators can be fitted in order to regulate the speed. A distinction is made between regulation of one fan or regulation of a number of fans at the same time.

5.1 MX without speed control

When the MX is delivered, it operates at the maximum set speed when connected to the power supply. This capacity is given on the label on the top of the controls. Remove the LUS3 from the clamp strip of the controls (see chapter 8.2) and the MX will operate at the minimum speed. In order to operate the fan at a different speed, this speed must be set using the Control Unit VU (see chapter 6.1).

5.2 Speed control of one MX fan

The following regulators are available for speed control of one MX fan.

SAG 0-M

Rotating switch for continuous adjustment of the speed. (see diagram 2 page 13 & SAG 0-M leaflet)

SAG 0-5

Rotating switch for adjustment of the speed in five positions. (see diagram 2 page 13 & SAG 0-5 leaflet)

SAG 0-2

Rotating switch for adjustment of the speed in two positions. (see diagram 2 page 13 & SAG 0-2 leaflet)

5.3 Speed control of a number of MX fans

The following regulators are available for speed control of a number of MX fans.

VG 31

Power supply unit for the parallel control of maximum 31 MX fans. The unit is fed with 230 V AC voltage. Depending on the speed regulation required, the power supply unit is connected to the SAG 0 - M, SAG 0-5 or SAG 0-2.

DNG 31

Unit for day/night switching of maximum 31 MX fans. The switching times are set with a timer. A central switch can be used to simultaneously switch all connected fans on and off. The unit is fed with 230 V AC voltage. The DNG 31 can also be used for day/night switching of MX-ZMV.

5.4 RSC servo contact

The servo contact can be used for the parallel switching of another system component, a valve for example. The servo contact is supplied in a separate housing which can be fitted under the cover of the MX, for example.

5.5 LTG temperature control

The LTG is a temperature regulator with which the MX speed can be continuously adjusted, depending on the temperature. The temperature is measured using the supplied temperature gauge. The temperature is set between 20°C and 50°C using a rotation knob on the housing. Rotation of a potentiometer in the housing adjusts the bandwidth between 0.5°C and 10°C. The speed of the MX varies between the minimum and maximum of the set bandwidth.



The LTG can also be used in combination with the VG31. One LTG can be used to control a number of fans.

cooling or heating

There is a choice between 'cooling' or 'heating'.

- For cooling, the MX will be speeded up when the temperature increases. A rotation knob on the LTG housing is used to set the temperature, whereby the MX operates at the minimum speed. The MX is speeded up as the temperature rises. The maximum speed is reached at the set temperature + bandwidth.
- For heating, the MX will be slowed when the temperature increases. The rotation knob on the LTG housing is used to set the temperature, whereby the MX operates at minimum speed. The MX is speeded up as the temperature drops. The maximum speed is reached at the set temperature - bandwidth.

The cooling or heating function can be set using a number of jumpers within the housing. The LTG also includes a jumper which can be used to select that the fan is switched off when it reaches the set temperature.

6. Communication

For example

The jumpers in the housing are set to 'cooling'. Temperature set at 25°C, bandwidth at 4°C. MX fan capacity set at: minimum 40%, maximum 80%.

At 25°C, the fan works at 40%, at $25 + 4 = 29^{\circ}\text{C}$, the fan works at the maximum capacity.

6.1 Reading and adjustment

Each MX is fitted with a connection for the Control Unit VU or a laptop/PC. This connection can be found under the MX cover.

Various units can be adjusted and read via this connection, such as:

- type of fan and controls;
- required capacity and limitations of minimum and maximum capacity;
- current speed;
- address and group number (for application of MX in a network);
- malfunctions.

6.2 VU Control Unit

The VU Control Unit allows for direct communication with the MX.

Method of operation

The plug of the unit is inserted into the MX connection. Once the Control Unit has been switched on, the current data of the MX is shown on the display of the unit. These settings can be changed.

Consider the following applications, for example:

- adjustment on site or subsequent re-adjustment of the capacity of the MX;
- setting an address (MX in network).

The unit is supplied in a case with a user's manual. Also included with the unit is a charging unit for charging in a car (12V) or via a wall socket (230V).

6.3 Communication with laptop/PC

The VENT-AXIA Maintenance Software can be used for direct communication between the laptop/PC and MX. An interface is used for connection of the MX to the laptop/PC.

The possibilities for adjustment and reading are virtually the same as those for the VU Control Unit.

The main difference is that, when communicating with a laptop/PC, the MX settings can be saved as a file. For a list of the options, refer to the 'VENT-AXIA Maintenance - Software – Networks – Communication Manual', available from VENT-AXIA.

6.4 MX network

A network of fans can be built, via inter-connection of a number of MX fans using the communication connection. The serial connection of each fan is double, in order to interconnect them. Each fan in the network is programmed with its own address, via the lap-top/PC or the Control Unit.

Besides the direct connection between the lap-top/PC or the Control Unit with the network, reading and adjustment can also take place remotely. From the lap-top/PC, a modem can be used to communicate with an MX network at a different location.

The MX network at location must be connected to the telephone net via a modem or other equipment, for this purpose. For more information, refer to the 'VENT-AXIA Maintenance – Software – Networks – Communication Manual', available from VENT-AXIA.

7. Installation

7.1 Installation conditions

- The MX must be installed according to the general and locally applicable safety and installation regulations.
- The MX must be fitted in such a manner that there is no risk of anybody touching the suction side of the fan (see EN 294).
- The permissible temperature of the air to be moved is from -30°C to +80°C.
- The fan is designed for continuous operation and must not be switched on and off more frequently than once every five minutes.

7.2 Transport, storage and unpacking

- The MX must be transported horizontally.
- During storage, the MX must be positioned horizontally.
- The fan should preferably be lifted using the recesses in the side of the housing or on the base.
- Ensure that the packaging materials are disposed of in an environmentally responsible manner.

7.3 Checking the delivery

- The type indication and other fan rating plate information must match that on the order.
- The box contains the manual and a bag with mounting bolts and rings, intended for attaching the MX to a mounting curb.

7.4 Installation

General

- It is vital that the roof construction or foundation on which the MX is to be installed is sufficiently rigid. If it is not rigid enough, undesirable vibrations may occur during operation of the fan.
- The fan must be installed using the supplied bolts and rings. Ensure that both the foundation and the surface into which the bolts are screwed are sufficiently strong to retain the fan even under severe weather conditions.
- The fan must be mounted horizontally to avoid rain and wind blowing into the fan. The maximum permissible angle of installation is 5° to the horizontal.
- Ensure that the four corners of the fan mounting base are level. An unlevel mounting base may result in uneven stress on the fan construction.
- The power supply cable, any control cables and possibly a pressure hose can be fed through a tube leading from under the base of the fan to under the hood. This tube is indicated under the hood as 'supply cable', see illustration 7.1. A tube to one of the recesses in the corners of the ventilators can be used to feed cables to the operating switch. This is indicated by 'cable', see illustration 7.1.

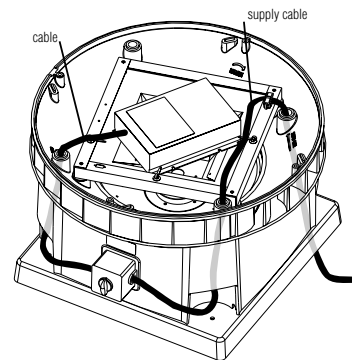

ill. 7.1

8. Electrical connection

8.1 Controls connection strip

The connection strip of the controls is shown below.

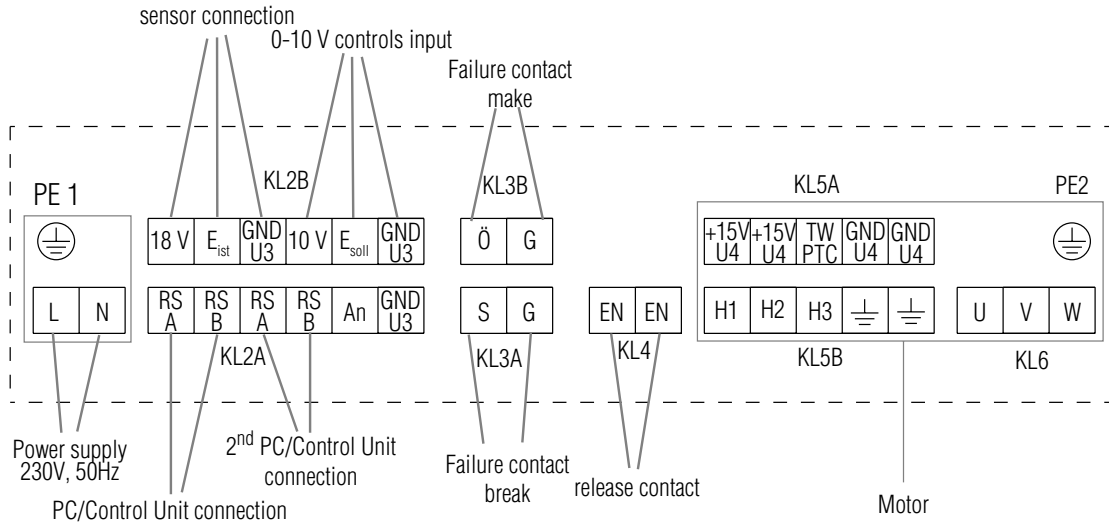

- 0–10 V controls input: for regulation of the speed of the MX using low voltage switches.
- Release contact: the current at this contact must be 10- 250 volt (AC or DC). When there is no current at the release contact, the fan will not work, even if there is 230 V power supply.
- Malfunction contacts: There is a make and break contact. In case of a malfunction, the contact between the two KL3A connectors is closed and between the two KL3B connectors is opened. The reverse situation occurs when there is 'no malfunction'.
- Communication connection: for adjustment and reading of the MX using the VU Control Unit or the laptop/PC. The contact is double: one A/B connection is connected to a sub-D9 connector in the frame, one A/B connector is free and can be used for looping when the MX is included in a network.

8.2 Wiring upon delivery

The MX standard

There are three links on the controls connection strip. One or more links may need to be removed in order to connect up control equipment. Refer to the applicable diagrams in chapter 8.4.

- LUS1 is used to connect the +10V to the first connector of the release contact.
- LUS2 is used to connect the GND to the second connector of the release contact.
- LUS3 is used to connect the +10V to the E_{soll} of the 0-10V controls input.

LUS1 and LUS2 provide current for the release contact. Via LUS3, there is 10V on the E_{soll} of the 0-10 controls input. The fan will therefore operate at maximum capacity following connection.

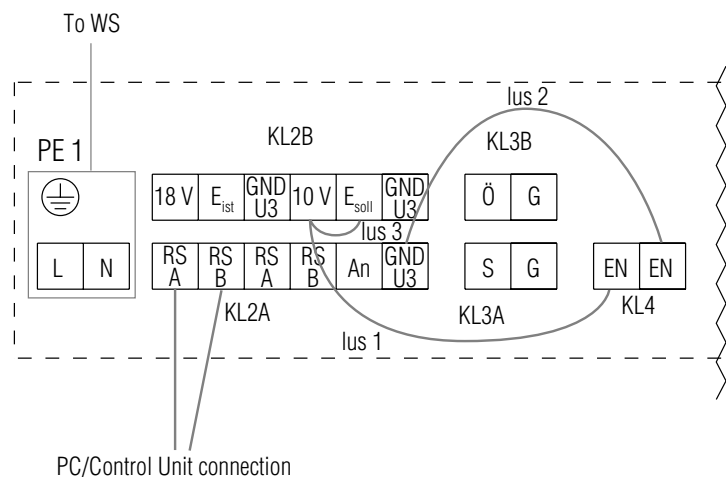

8.3 Relationship between speed and current at 0-10V controls input

When connecting regulators, the speed of the MX is controlled by varying the voltage at the 0-10 V controls input.

Measurement of the voltage between E_{Soll} and GND connectors of the 0-10V controls input allows for the speed of the fan to be derived from one of the graphs given below. The current between E_{Soll} and GND can be measured both on the MX (two connectors of the 0-10 V controls input) and the switch/regulator connected.

Adjustment example

If you wish to adjust an MX 20/10 to two speeds using the SAG 0-2: 750 rpm and 1000 rpm, follow the example below.

- Turn the switch to position '1'.
- Rotate the n1 potentiometer until the voltage between the GND and E_{Soll} connectors is 3.8 V. This corresponds with 750 rpm, see the characteristic of the MX 20/10 below.
- Now turn the switch to position '2'. Now rotate the n2 potentiometer until 5.5 V is given, which corresponds with 1000 rpm.

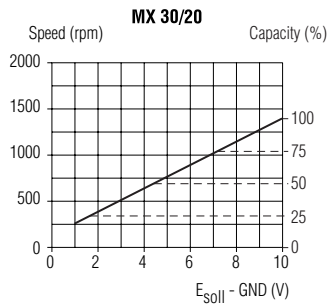
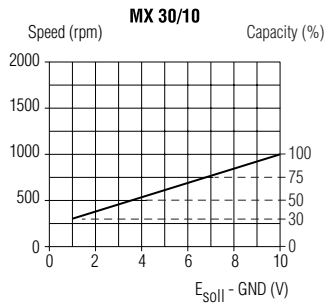
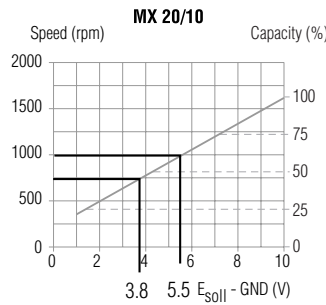
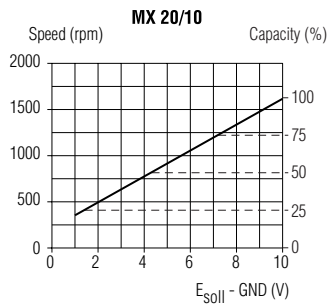
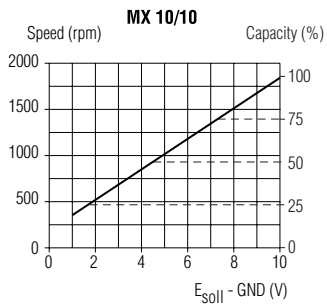

These graphs apply only if the minimum and maximum capacity setting has not been changed.

The minimum and maximum capacity can be adjusted using the VU Control Unit or the laptop/PC. This means that the graphics of the fan change.

Example

Min. Capacity 50% and Max. Capacity 70% means 50% at 0 V and 70% at 10 V at the 0-10V controls input.

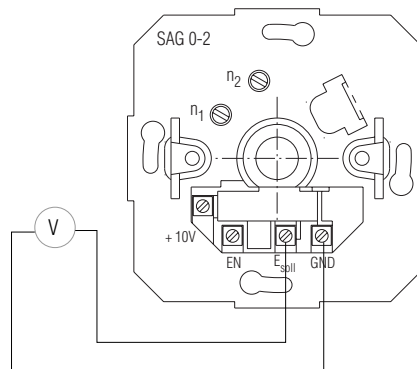
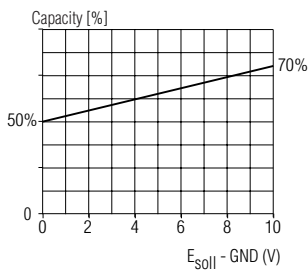

8. Electrical connection

The fan is connected in accordance with the applicable diagram.

 A number of diagrams may be simultaneously applicable.
The fan is class 1 and must be earthed

8.4 Wiring diagrams

MX (standard) wiring diagram

diagram 1

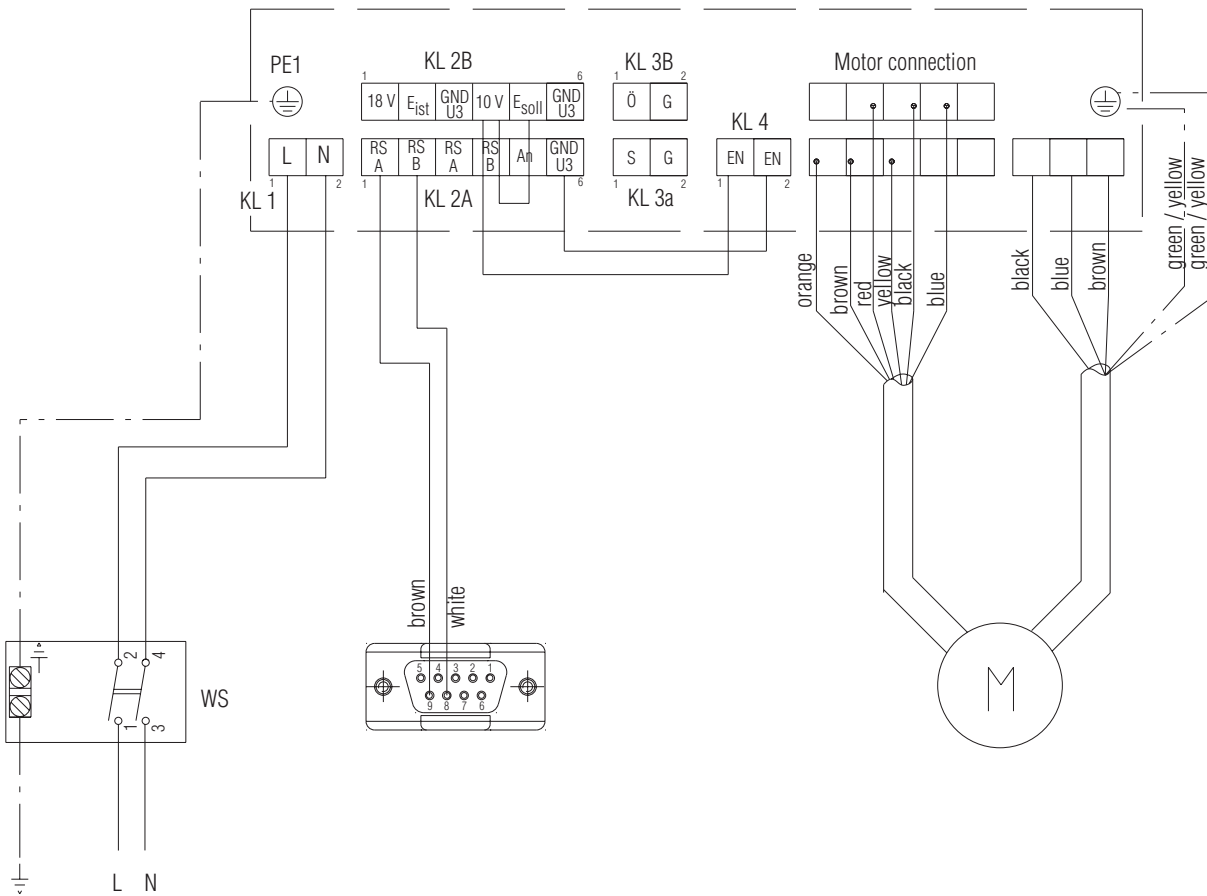

SAG 0-2 / SAG 0-5 / SAG 0-M wiring diagram diagram 2

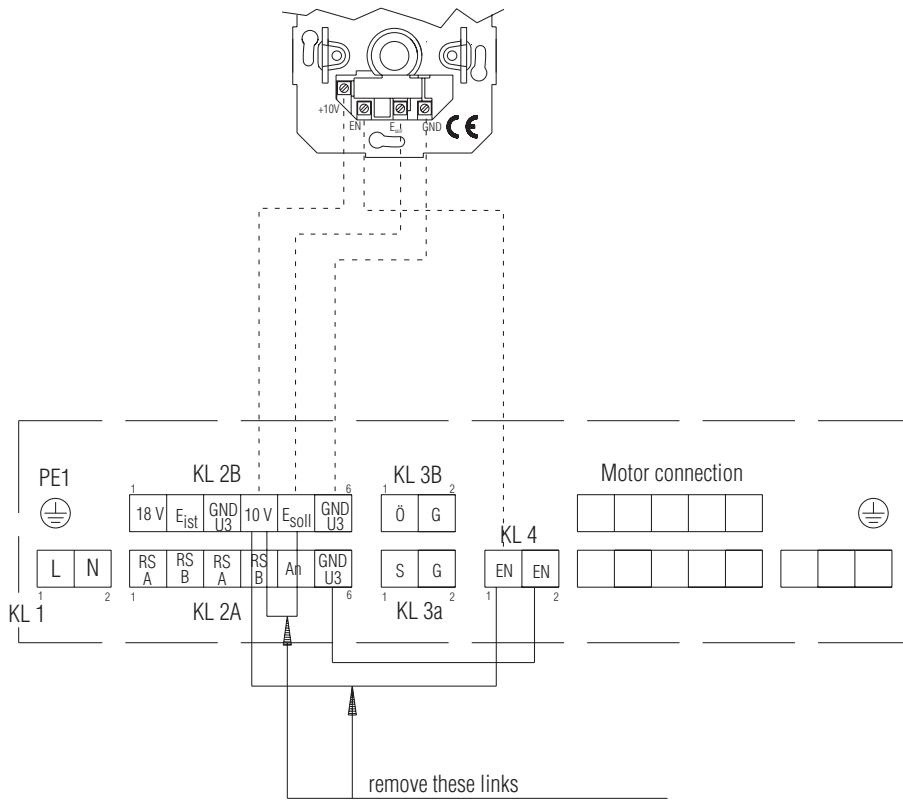

VG 31 wiring diagram diagram 3

Use VG 31 in combination with switch SAG

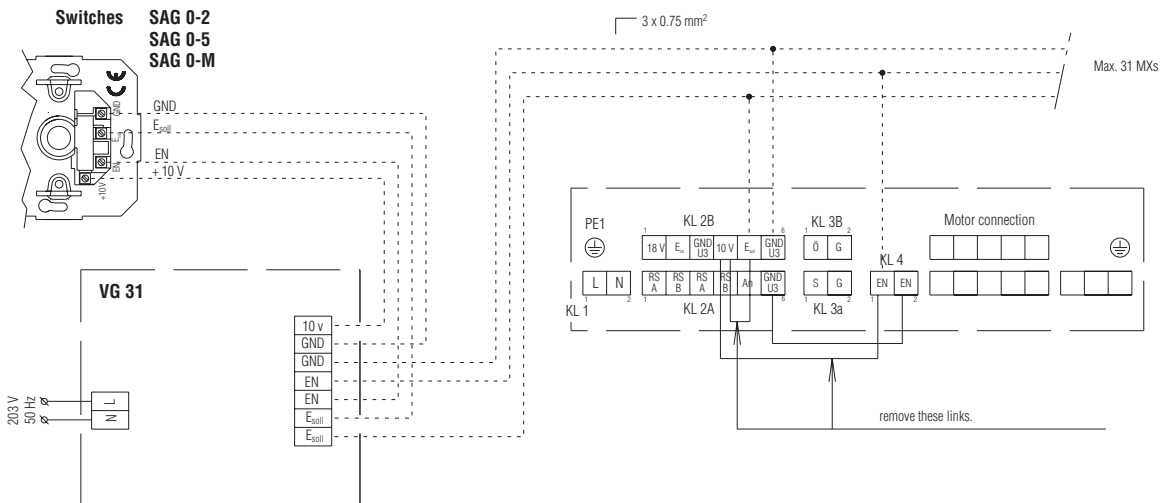

8. Electrical connection

DNG 31 wiring diagram
 diagram 4

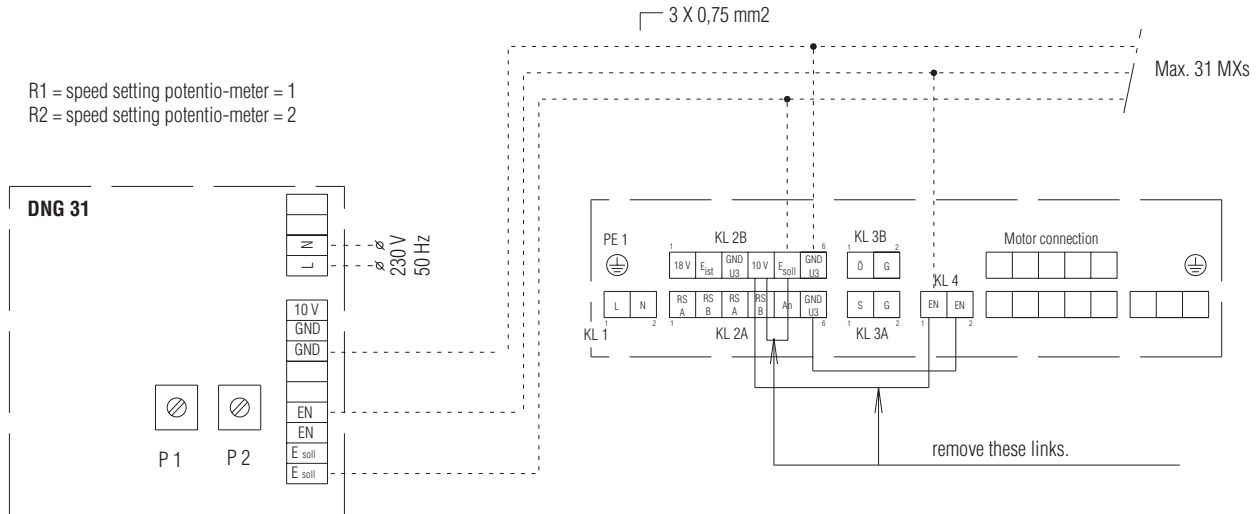

RSC wiring diagram
 diagram 5

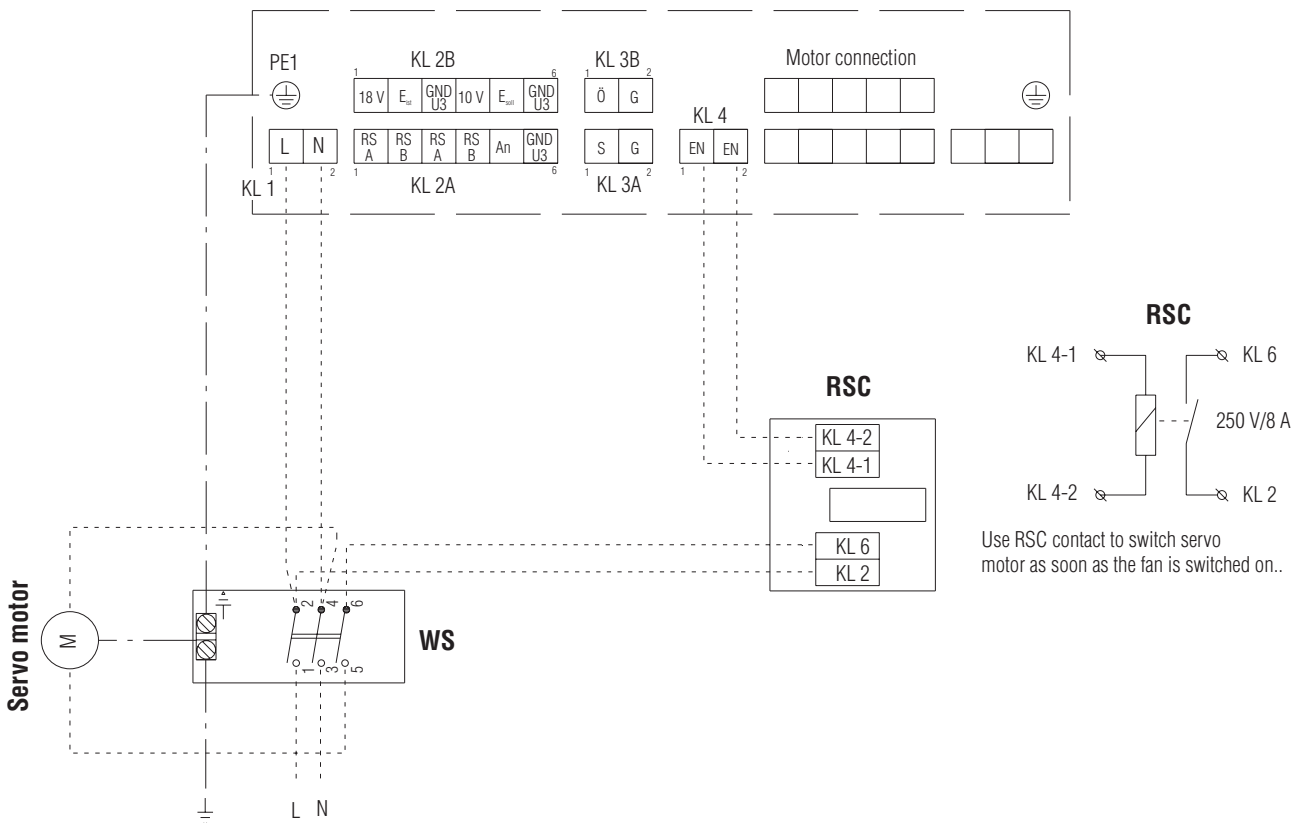

LTG wiring diagram diagram 6

R=upper temperature setting potentiometer
R7=band width setting potentiometer

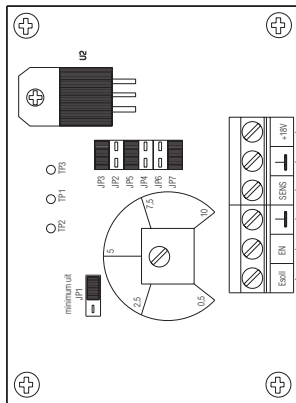

Jumpers (removable link) in 4 positions shown below

- heating: to JP2, JP4, JP7
- cooling: to JP3, JP5, JP7
- upon reaching the set temperature, the fans must switch on: JP1 to 'uit'
- upon reaching the set temperature, the fans must continue rotation at minimum speed: JP1 to 'minimum'

external sensor

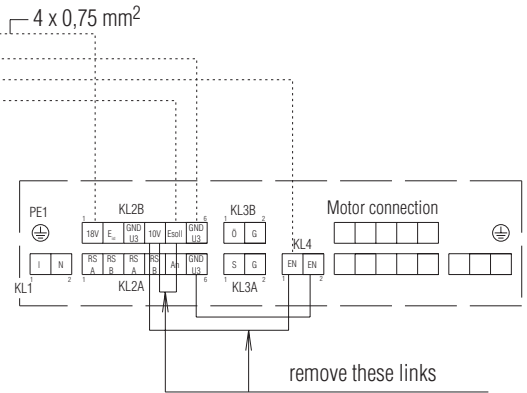

Cooling

temperature setting 20°C
band width 5°C

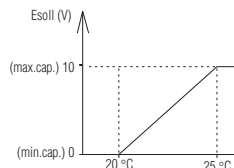

Heating

temperature setting 20°C
band width 5°C

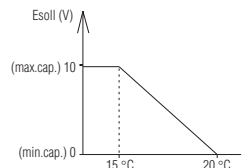

Wiring diagram for linking of MX malfunction contacts (potential-free)

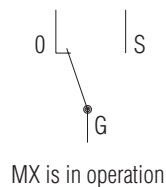
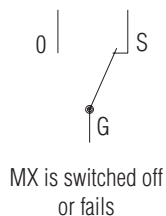
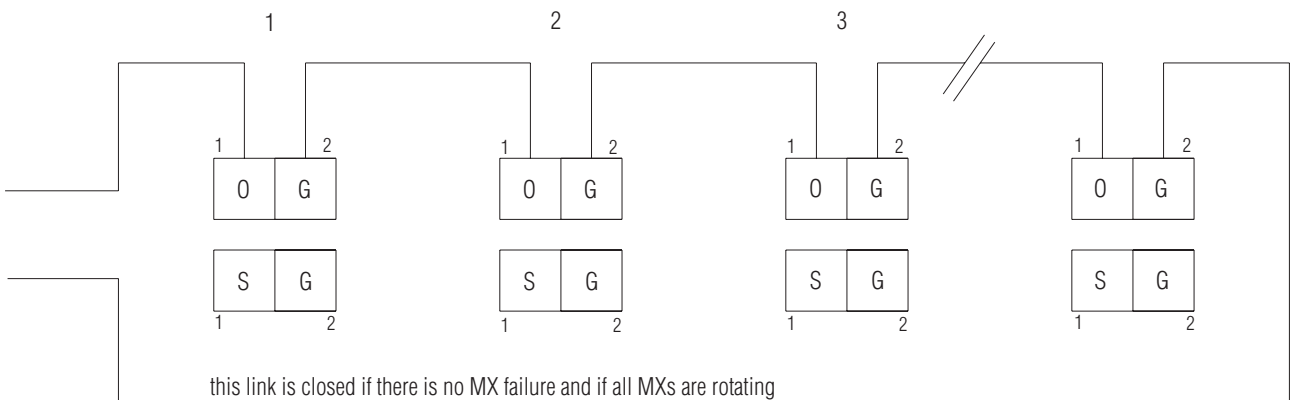

8. Electrical connection

diagram 7
Wiring diagram for MX in network

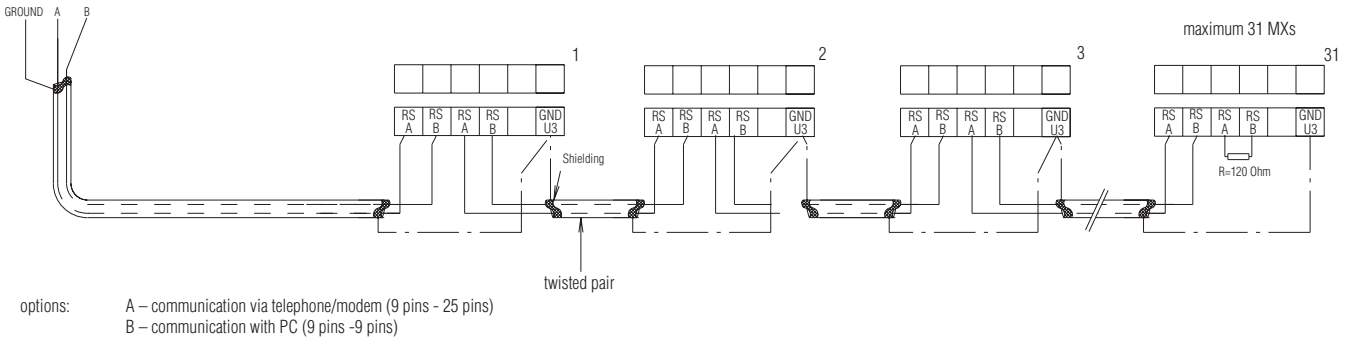
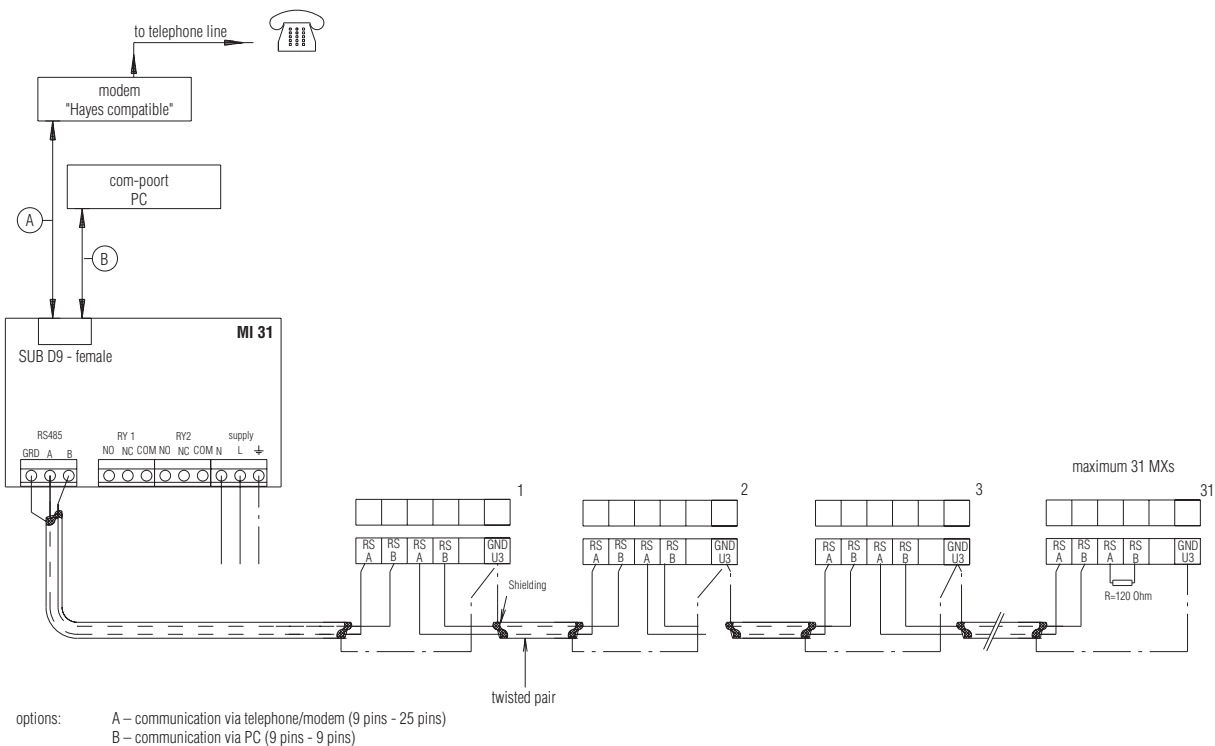

diagram 8

Wiring diagram for MX in network with modem communication

diagram 9



9. Adjustment

9.1 Summary of MX settings

Adjust the MX settings and any control equipment according to the applicable column. The MX is pre-set to the given values. Do not change these values unless absolutely necessary. At [...] fill in the value set by you.

Standard:	DNG 31	SAG 0 – 2	SAG 0 – M SAG 0 – 5	LTG	
Wiring diagram	1	1 + 5	1 + 3 of 4	1 + 3 or 4	2 + 5
Possibly also diagram:	6-8-9-10	6-8-9-10	6-8-9-10	6-8-9-10	6-8-9-10
In MX (with VU)					
Mode	Control	Control	Control	Control	External
Set point	Ana 0..10V	Ana 0..10V	Ana 0..10V	Ana 0..10V	Dig 0/10
Sensor	None	None	None	None	0-300
Regulation	Positive	Positive	Positive	Positive	Positive
Address *	1 or [...]	1 or [...]	1 or [...]	1 or [...]	1 or [...]
Group *	1 or [...]	1 or [...]	1 or [...]	1 or [...]	1 or [...]
Minimum capacity	15 % **	15 % **	15 % **	15 % **	15 % **
Maximum capacity	100 % or [...] %	100 %	100 %	100 %	100 %
Set point digital (0)	-	-	-	-	Low
Set point digital (1)	-	-	-	-	High,
Set point RS-485	-	-	-	-	-
Write / reset Reset	Write/ Reset	Write/ Reset	Write/ Reset	Write/ Reset	Write/ Reset
Save / set *	For similar setting in other MX	For similar setting in other MX	For similar setting in other MX	For similar setting in other MX	For similar setting in other MX
In SAG					
Speed n1			[...] V		
Speed n2			[...] V		
Maximum speed				[...] V	
In LTG					
Potential-meter (bandwidth)					[...] °C
Jumper (removable link)				see manual [...]	LTG
In VG 31					
In DNG 31					
Time switch	Times low [...]	high[...]			high[...]
Switch		To			To
Low (R1)		[...] V			Potential-meter
High (R2)		[...] V			Potential-meter
RSC	-		-	-	-

- No adjustment necessary.

* If the fan is part of a network, follow the instructions on page 18.

** The minimum capacity of the MX 30/10 has not been factory set at 15% but rather at 30%.

9. Adjustment

9.2 MX network: addressing, settings and copying of settings

If more than one MX is connected (see diagrams 8 + 9), each MX must have its own address.

Addressing

1. Make a (roof) summary of all fans, divide the fans into groups of a maximum of 31 and note an address number and group number by each fan.
2. Use the operating switch to turn off all the fans connected in this network.
3. Connect the VU to the first MX.
4. Turn this fan on only.
5. Enter the correct address in the 'Settings' menu under 'Address'.
6. Enter the correct group number in the 'Settings' menu under 'Group'.
7. Possibly also note the address in the table on page 17 of the manual for this fan.
8. Select 'Write/reset' 'Write/reset' in the 'Settings' menu.
9. Now turn this fan off again.
10. Connect the VU to the next MX.
11. Repeat points 4 to 10 for each MX of this network.
12. Turn all the fans back on.

Settings

13. Connect the VU to a random MX.
14. Press the 'Menu' key ('Main menu' will appear).
15. Choose the correct group under 'MX Group no.' in the 'Main menu'.
16. Choose the correct address under 'MX network' in the 'Main menu'.
17. Set the MX in the 'Settings' menu, according to the table on page 17.
18. Note the new setting in the table on page 17 of the manual for this fan.

More than one MX of the same type and with the same setting.

19. Select 'Save/set' then 'Save' in the 'Settings' menu.
20. Possibly choose the next group under 'MX Group no.' in the 'Main menu'.
21. Choose the next address under 'MX network' in the 'Main menu'.
22. Select 'Save/set' then 'Set' in the 'Settings' menu.
23. Select 'Write/reset' 'Write/reset' in the 'Settings' menu.

9. Adjustment

9.3 Control of air volume

The air volume is determined by the speed of the impeller and the external resistance in the mounting curb, see the graph on page 5.

The speed can be determined by:

- measuring with the aid of a stroboscope;
- reading the speed with the VU Control Unit in the 'Status' menu under 'Speed'.
- measuring the voltage on the 'E_{soll}' and 'GND U3' connector and plotting these measured values in the applicable graph on page 14. These graphs only apply if the MX has been set at minimum speed 15%* and maximum speed 100% (this is the standard factory setting). If these settings are different, the applicable graph must be adjusted accordingly.

* The minimum capacity of the MX 30/20 has been factory set at 25%.

Example

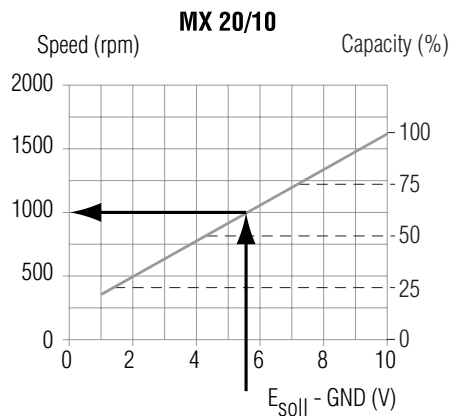

Measured voltage 5.5 V
Speed is 1000 rpm

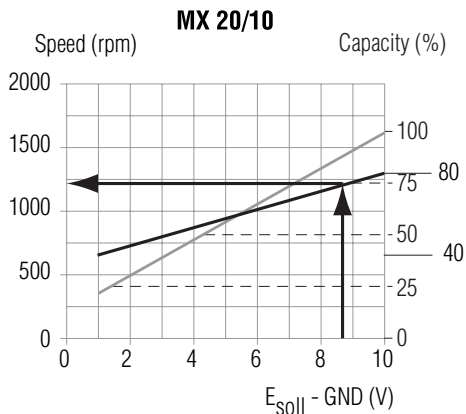

Minimum capacity setting 40%
Maximum capacity setting 80%
Measured voltage 8.7 V
Speed is 1200 rpm

The external resistance can be determined by:

- measuring the external resistance in the mounting curb;

The air volume can now be determined.

- Now plot the speed line found in the graph on page 5.
- Now draw a line from the external resistance found to the right.
- Draw a line vertically from the intersecting point found and determine the air volume.

Example

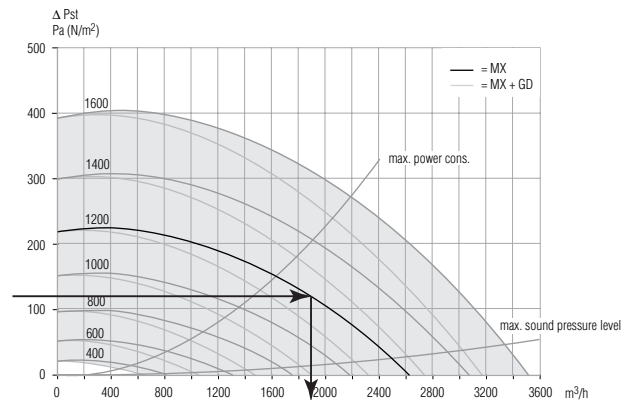

Speed 1200 rpm
External resistance 120 Pa
Air volume is 1900 m³/h

Conclusions

More air than the design value means that the resistance in the system is lower than the design value.

Possible causes are:

- lower duct resistance than assumed;
- valves or grilles have not be fitted or adjusted (open too far);
- leakage in the duct system. Compare the air volume with the total measured air volume through the valves.

Less air than the design value means that the resistance in the system is higher than the design value.

Possible causes are:

- higher duct resistance than assumed;
- valves or grille not adjusted (too far closed);
- blockage in the duct system. Compare the air volume with the total measured air volume through the valves.

9. Adjustment

9.5 Measuring report

Type of fan							
Group / address / Set point		/		/			
Pressure set at Pa							
Net:							
Room:		Kitchen	Kitchen	Bathroom	Toilet
Type of valve or extractor hood:							
Required air delivery high: in l/s or m³/h*							
LEVEL		A					
		Q					
		A					
		Q					
		A					
		Q					
		A					
		Q					
		A					
		Q					
		A					
		Q					
		A					
		Q					
		A					
		Q					
		A					
		Q					
		A					
		Q					

A = Setting of the valve or extractor hood

Q = Air volume in l/s or m³/h*

* Delete that which is not applicable.

10. Inspection and maintenance

Exploded view

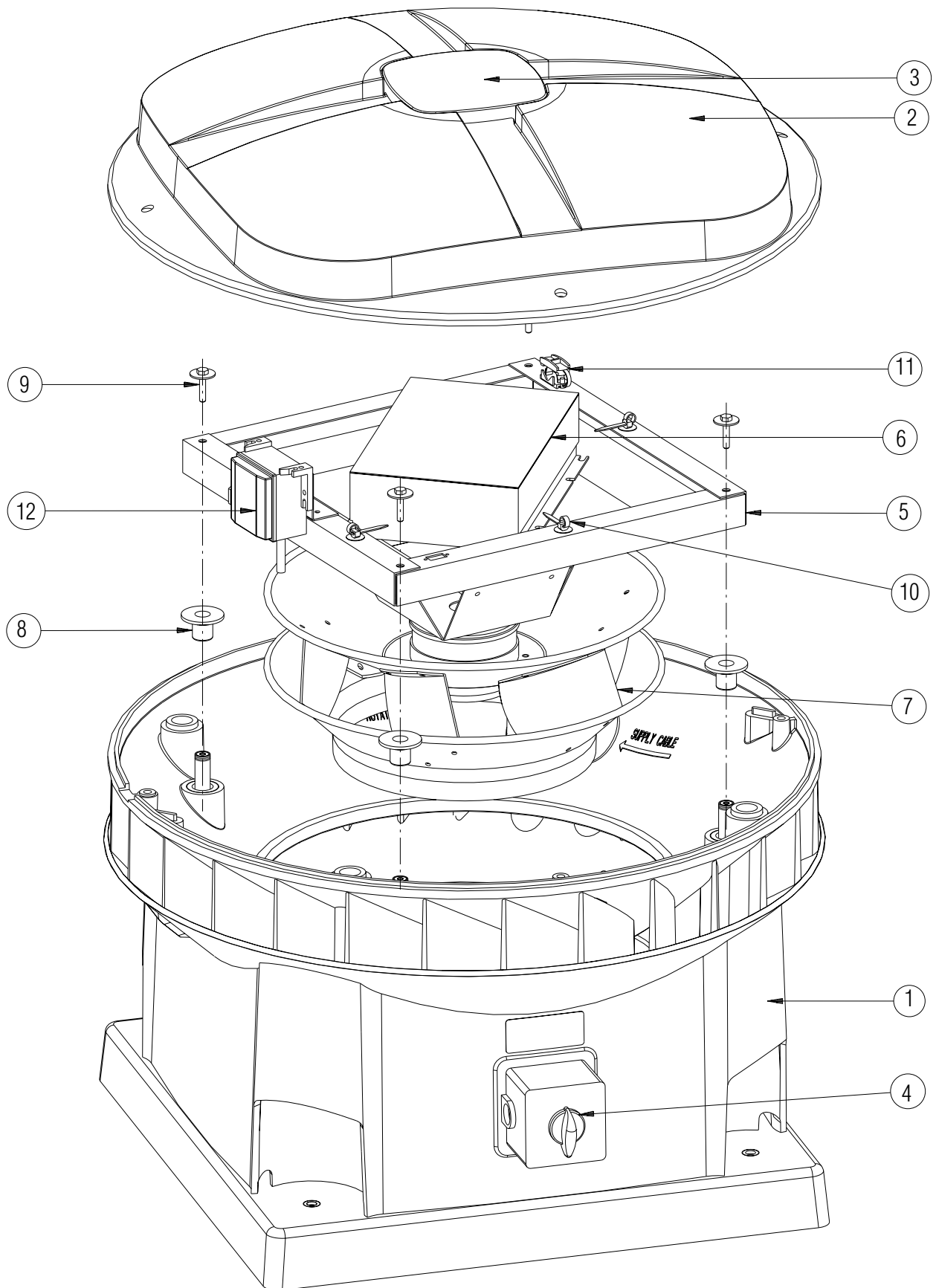

10. Inspection and maintenance / 11. Malfunctions

10.1 Inspection and maintenance

The fan must be inspected once every two years. This depends on the degree of pollution of the air. More frequent inspection is required in the case of extreme pollution. Examples could include extraction in institutional kitchens or industrial processes.

- Make sure that (parts of) the ventilator not (yet) anchored and tools cannot fall/blow off the roof or cause damage or personal injury in any other manner.
- When the ventilator is completely or partly dismantled, make sure nobody can touch rotating parts or live parts.
- Do not leave a (partly) dismantled fan which is connected to the power supply, unattended.
- Make sure that parts which conduct electricity do not become wet.

Proceed as follows for inspection or maintenance. (ref to exploded view of fan)

1. Turn off the fan using the service isolator (4).
2. Remove the fan cover (2).
3. Unscrew the 4 bolts (9).
4. Lift the inner fan components (5) (motor-impeller, frame and housing) vertically and then lay them upside down in the housing.

 Take care not to damage the cables and air hoses.

5. If necessary, clean the impeller (7) carefully using a soft brush.

 Do not damage or bend the impeller.

6. If the bearings are defective, replace the motor-impeller.*
7. If necessary, clean the housing (1) carefully using a soft brush.
8. Insert the inner components (5) back in place.
9. Check that the impeller (7) can rotate freely.
10. If necessary, clean the controls (6) carefully using a soft brush.
11. Check that the cables and hoses are not lying against sharp edges of the frame or the controls.
12. Make sure the cables cannot come in contact with the impeller (7).
13. Clean the air cap (3) in the fan cover.
14. Fix the fan cover back in place (2).
15. Turn the fan back on using the service isolator (4) and check whether it works properly.
16. Also check whether the fan reacts properly to the regulator(s), if fitted.

* Bearings cannot be replaced. This is due to the permanent magnets in the motor. The complete motor-impeller must then be replaced. Follow the instructions for replacement of the motor-impeller.

11.1 Malfunction tables

Two malfunction tables have been included below.

The first table is for identification of a malfunction in an MX. It begins when a complaint is received.

The second table is intended for identification of a malfunction in an MX installation with regulator(s). Use this table to check the complete regulator circuit. Check the entire installation according to the table. Follow the instructions from the top down. Only follow those instructions which are marked in the appropriate column.

In the first table, there are 2 references to the previous page. This is in order to check the pressure transmitter. Proceed as follows:

- Make sure there is 18V (=form the controls or external) on connector '18V' and 'GND U3' of the sensor.
- Measure the regulating signal at the 'Eist' and 'GND U3' connectors. This must vary if you blow carefully into the hose which measures the exterior pressure. This pressure must increase upon blowing.
- Compare the measured pressure through the pressure sensor (the 'Sensor' value in the 'Status' menu) with the measured pressure through a 'foreign' pressure meter. Use the same pressure hoses on the two meters.

Complaint	LED on controls for	Possible	What do I measure	Display in 'Malfunctions' menu	Particulars in 'Status' menu	Cause	Action
Rotates (too slowly)	Red	All	15V = between '15V' and 'GND U4' connectors 7V = between 'TW PTC' and 'GND U4' connectors	Motor temp.	Speed is lower than required speed.	Motor runs with difficulty	Replace the motor-impeller
Rotates too slowly and makes too much noise	Red	All	15V = between '15V' and 'GND U4' connectors 7V = between 'TW PTC' and 'GND U4' connectors	Motor temp.	Speed is lower than required speed.	Impeller sticks	Check for damage and replace any damaged parts
Rotates constantly at high speed	Green	External Regulators	10V = between 'E _{soil} ' and 'GND U3' regulator is in regulating position	None	According to 'settings' high	(Wiring to) regulator is broken (GND U3).	Check (wiring to) regulator and replace if necessary, see second table.
Rotates at constantly low speed	Green	External Regulators	If '10V' and 'E _{soil} ' connectors are connected, ventilator does not speed up. Disconnect 'E _{soil} ' wire	None	According to 'settings' low	Controls defective	Replace controls
Rotates at constantly low speed	Green	External Regulators	If '10V' and 'E _{soil} ' connectors are connected, ventilator does speed up. Disconnect 'E _{soil} ' wire	None	According to 'settings' low	(Wiring to) regulator is broken	Check (wiring to) regulator and replace if necessary, see second table.
Rotates constantly at maximum speed	Green	ZMV	OV = between '18V' and 'GRD U3' connector of the controls	None	Sensor: 1 Pa	Controls defective	Replace controls
Rotates constantly at maximum speed	Green	ZMV	18V = between '18V' and 'GRD U3' connectors OV = between 'E1st' and 'GRD U3' connector of the controls	None	Sensor: 1 Pa	(wiring to) pressure transmitter is defective	Check (wiring to) pressure transmitter, and replace if necessary, see previous page.
Rotates constantly at maximum speed	Green	ZMV	18V = between '18V' and 'GRD U3' connectors OV = between 'E1st' and 'GRD U3' connector of the controls	None	Sensor: 1 Pa	No pressure difference is measured	Check the place of pressure measurement. Is the air hose bent or loose?
Rotates constantly at minimum speed	Green	ZMV	No 18V = between '18V' and 'GRD U3' connectors of the controls	None	Sensor: (±) 300 Pa	Controls defective	Replace controls
Rotates constantly at minimum speed	Green	ZMV	18V = between '18V' and 'GRD U3' connectors of the controls	None	Sensor: (±) 300 Pa	(wiring to) pressure transmitter is defective	Check (wiring to) pressure transmitter, and replace if necessary, see previous page.
Does not rotate	Green	All	No 10V or more at release contact	None	Speed: 0 rpm	Break in the release circuit.	Check release circuit, also between MX and regulators, see second table.
Does not rotate	Red	All	No 15V = between '15V' and 'GND U4' connectors	Motor blocked	Speed: 0 rpm	Controls defective	Replace controls
Does not rotate	Red	All	15V = between '15V' and 'GND U4' connectors	Motor blocked	Speed: 0 rpm	Break in motor controls wiring	Check (wiring to) motor-impeller and replace if necessary
Does not rotate	Red	All	15V = between '15V' and 'GND U4' connectors	Hall sensor	Speed: 0 rpm	Break in motor controls wiring	Check (wiring to) motor-impeller and replace if necessary
Does not rotate	Off	All	No 230V ~ between 'L' and 'N'	No connection	-	No current	Check operating switch connection and electrical installation
Does not rotate	Off	All	230V ~ between 'L' and 'N'	No connection	-	Controls defective	Replace controls
Does not rotate	Red	All	Internal Com. error	Temp. controls	-	Controls defective	Replace controls
Does not rotate	Red	All	Temp. controls	None	Nothing in particular	Impeller out of balance	Replace controls
Ventilator vibrates	Green	All	Nothing in particular	None	Nothing in particular	Impeller out of balance	Check impeller for pollution or replace the motor-impeller
Ventilator makes excessive noise	Green	All	Nothing in particular	None	Nothing in particular	Bearings defective	Replace the motor-impeller
Ventilator makes excessive noise	Green	All	Nothing in particular	None	Nothing in particular	Impeller sticks	Check whether anything is caught in the rotor or the impeller is running against the base or against the cabling to the motor
VU settings are not applied	Green/Red	All	Nothing in particular	None	Nothing in particular	Controls defective	Replace controls

Resetting: Every malfunction (LED on controls is red) must be reset by turning off the fan and waiting until the LED is green, then turning the fan back on again.

Or: using VU in the 'Settings' menu, then 'Write/reset'. Take note: The settings of the 'Settings' menu are passed on to the fan.

11. Malfunctions

Carry out check of:	Check to be carried out. If yes, go to the next line	If no, the malfunction is in the :	SAG 0-2 SAG 0-5 SAG 0-M	LTG SAG or LTG + VG 31	DNG 31
VG 31 or DNG 31	230V~ on 'L' and 'N' connectors?	Electrical installation		X	X
VG 31 or DNG 31	10V= on '+10V' and 'GND' connectors?	VG 31 or DNG 31, check F3 fuse		X	X
DNG 31	10V= on connectors 'EN UIT' and 'GND' switch on. 0V= on connectors 'EN UIT' and 'GND' switch off.	DNG 31			X
DNG 31	Adjust potentiometer R1. Does the voltage vary between connector '1' and 'GND'? (Reset the potentiometer to the same voltage).	DNG 31			X
DNG 31	Adjust potentiometer R2. Does the voltage vary between connector '2' and 'GND'? (Reset the potentiometer to the same voltage).	DNG 31			X
DNG 31	Switch the timer manually. Does the voltage vary between 'E _{soil} IN' connector and 'GND'?	DNG 31 Timer. See also the timer manual for timer control			X
DNG 31	Switch the timer manually. Does the voltage vary between 'E _{soil} UIT' connector and 'GND'?	DNG 31 Check F2 fuse			X
MX	Remove the wire on 'E _{soil} ' connector. Does the MX start working in low speed?	MX controls	X		
MX	Connect up '10V' and 'E _{soil} ' connectors. Disconnect 'E _{soil} ' wire Does the MX start working in high speed?	MX controls	X		
MX	Remove the wire on 'EN' connector. Does the impeller stop?	MX controls	X		
MX	Return the wiring to its original state.		X		
SAG	Is there 10V= on '10V*' and 'GND' connectors?	MX – SAG cabling	X	X	
SAG	Set the SAG to position '0'. Does the MX switch off?	MX – SAG cabling Is there release applied?	X	X	
SAG	Connect up '10V*' and 'EN' connectors. Does the MX start working in low speed?	MX – SAG cabling	X	X	
SAG	Also connect up '10V*' and 'E _{soil} ' connectors. Disconnect 'E _{soil} ' wire Does the MX start working in high speed?	MX – SAG cabling	X	X	
SAG	Return wiring to its original state		X	X	
SAG	Turn the regulator knob. Does the voltage vary on 'E _{soil} ' and 'GND' connectors?	SAG	X	X	
SAG	Knob in position '0', no connection between '10V*' and 'EN' connectors. Knob in any other position, with connection between '10V*' and 'EN' connectors. Is that correct?	SAG	X	X	
VG 31	Turn the SAG knob. Does the voltage vary between 'E _{soil} UIT' connector and 'GND'?	VG 31 Check F2 fuse		X	
VG 31	10V= on 'EN UIT' and 'GND' connectors SAG not at position '0'. 0V= on 'EN UIT' and 'GND' connectors SAG at position '0'.	VG 31		X	
MX	Remove the wire on 'E _{soil} ' connector. Does the MX start working in low speed?	MX controls		X	X
MX	Connect up '10V' and 'E _{soil} ' connectors. Disconnect 'E _{soil} ' wire Does the MX start working in high speed?	MX controls		X	X
MX	Remove the wire on 'EN' connector. Does the impeller stop?	MX controls		X	X
MX	Return wiring to its original state Do the controls work well?	MX – VG31 or DNG 31 wiring		X	X

* If there is an LTG, substitute '18V connector' for '10V connector'.

11.2 Replacement of components

Always apply the valid safety regulations and instructions.

- Make sure that (parts of) the fan not (yet) anchored and tools cannot fall/blow off the roof or cause damage or personal injury in any other manner.
- When the ventilator is completely or partly dismantled, make sure nobody can touch rotating parts or live parts .
- Do not leave a (partly) dismantled fan which is connected to the power supply, unattended.
- Make sure that parts which conduct electricity do not become wet.

Motor impeller

1. Turn off the fan using the service isolator (4).
2. Remove the fan cover (2).
3. Pull the connected switches out of the controls and remove the earth wires.
4. Unscrew the controls (6).
5. Undo the retaining brace (10) with which the motor wires are bound up.
6. Unscrew the motor (7) from the frame. The motor impeller may be left to lie in the housing.
7. Unscrew the 4 bolts (9).
8. Remove the frame. Take care not to damage any wires or hoses.
9. Remove the motor impeller (7).
10. Lay the new motor impeller in the housing.
11. Put everything back in the reverse order. Take care that cables and hoses are put back in the right place.
12. Check that the impeller (7) can rotate freely.
13. Check that the cables and hoses are not lying against sharp edges of the frame or the controls.
14. Make sure the cables cannot come in contact with the impeller (7).
15. Turn the fan back on using the service isolator (4) and check whether it works properly.
16. Also check whether the fan reacts properly to the regulator(s), if fitted.
17. Fix the fan cover back in place (2).

Controls

1. Remove the fan cover (2).
2. Connect a VU manual unit onto the sub D9 connector.
3. Select 'Save/set' then 'Save' in the 'Settings' menu.*
4. Turn off the fan using the service isolator (4).
5. Pull the connected switches out of the controls and remove the earth wires.
6. Unscrew the controls (6).
7. Install the new controls.
8. Attach all plugs and earth wires.
9. Check that the cables and hoses are not lying against sharp edges of the frame or the controls.
10. Make sure the cables cannot come in contact with the impeller (7).
11. Switch on the fan using the operating switch (4).
12. Select 'Save/set' then 'Set' in the 'Settings' menu.
13. Check whether everything works properly.
14. Also check whether the fan reacts properly to the regulator(s), if fitted.
15. Fix the fan cover back in place (2).

* Does this function no longer work due to the defect? Make use of the information on the sticker on the controls for point 12. Or that of a comparable fan. Or set point 12 in accordance with the settings list or the table on page 15.

Pressure transmitter

1. Turn off the fan using the service isolator (4).
2. Remove the fan cover (2).
3. Remove hose connections on the pressure transmitter (12). Take note of where the hoses belong.
4. Remove the electrical connection in the pressure transmitter.
5. Undo the retaining brace (10) with which the wires are bound up.
6. Remove the pressure transmitter.
7. Install the new pressure transmitter.
8. Re-attach the electrical connection and hose to the pressure transmitter.
9. Check that the cables and hoses are not lying against sharp edges of the frame or the controls.
10. Make sure the cables cannot come in contact with the impeller (7).
11. Switch on the fan using the operating switch (4).
12. Check whether everything works properly.
13. Also check whether the fan reacts properly to the regulator(s), if fitted.
14. Fix the fan cover back in place (2).

MX service parts

Component	Number	MX 10/10	MX 20/10	MX 30/10	MX 30/20	
Housing	1	448000010	448000020	448000030	448000030	
Fan cover	2	448000110	448000120	448000130	448000130	
Air cap	3	448000200	448000200	448000200	448000200	
Operating switch	4	660030040	660030040	660030040	660030040	
Frame	5	348000010	348000020	348000030	348000030	
Controls	6	655000140	655000140	655000140	655000140	
Motor-impeller	7	476900010	476900020	476900030	476900030	
Sealing rubber	8	850000130	850000130	850000130	850000130	
Retaining brace	10	875000020	875000020	875000020	875000020	
Pull relief	11	860000300	860000300	860000300	860000300	
Pressure transmitter	12	660000040	660000040	660000040	660000040	
Conversion set MX->MX+ZMV		476000007	476000007	476000007	476000007	
Cable control-pressure transmitter	13	682030778	682030778	682030778	682030778	
Cable control-switch	14	682031504	682031504	682031504	682031504	
Wire + sub-D9 connector	15	682010068	682010068	682010068	682010068	
Pressure hose		030000830	030000830	030000830	030000830	
Fan installation set		804063200	804063200	804063200	804063200	
ZMV installation set		476000006	476000006	476000006	476000006	
MX manual		849050400	849050400	849050400	849050400	
Resistance 120 ?		676012000	676012000	676012000	676012000	
VU controls unit in case		498200005	498200005	498200005	498200005	
SAG						
	SAG button	660800010	DNG 31	F2 1AT fuse	676000030	
	SAG 0-2 cover plate	660800011		F3 315 mA T fuse	676000060	
	SAG 0-5 cover plate	660800012		Time switch	660800040	
	SAG 0-M cover plate	660800013		Switch	660800041	
	Rosette	660800014		DNG housing	660800042	
LTG						
	LTG button	660800020	Front plate with LED interface	Housing	660800050	
LTG housing		660800021		PC modem		660800051
VG 31		F2 1AT fuse			315 mA T fuse	676000060
		F3 315 mA T fuse			Modem cable 9/25	821000073
		VG housing		PC cable 9/9	821000074	

9.3 Phased plan for adjustment

If the MX is intended for residential ventilation, use this table.
Follow the marked directions from the top down in the column which is applicable.

ZMV	STB valves and extractor hoods					
	Only STB valves					
	STZ valves also with 2 positions and/or extractor hoods					
	Only STZ valves without 2 positions					
None	STB valves and extractor hoods					
ZMV	Only STB valves					
Set the MX according to the table on page 21	X	X	X		X	X
Also set the calculated constant pressure.			X	X	X	X
Also set the calculated maximum capacity.	X	X				
Set any external regulators to the highest position	X	X	X	X	X	X
Close windows and doors	X	X	X	X	X	X
Open all intake openings intended for that purpose.	X	X	X	X	X	X
Make sure there are constructional overflow facilities (min. 12 cm ² per l/s).	X	X	X	X	X	X
Install the valves and set these according to the calculated settings chart	X	X			X	X
Install the correct valves in the correct area.			X			
Install the correct valves in the correct area. Close the 2 position valves.				X		
Install the extractor hoods and set the butterfly valves according to the calculated settings chart						
Close the extractor hoods		X		X		X
Check the air volumes through the valves						
Start as close as possible to the fan.	X	X				
Check the air volumes through the valves.						
Start as close as possible to the place where the pressure is measured.					X	X
Check the underpressure behind the valve furthest from the fan. This must be minimum 50 Pa.			X	X		
Check the underpressure behind the valve closest to the fan. This must be maximum 200 Pa. Arrange for extra resistance in the branch, if necessary.						
If the majority of the deviations is minus (or plus), ensure that all the deviations are minus (or plus). Also ensure that the most unfavourable valve is completely open	X	X			X	X
Adjust the required % 'Maximum capacity' if necessary. Refer to the table. The lower the figure, the less energy used.	X	X				
Adjust the required pressure 'Set point digital (1)' if necessary. Refer to the table. The lower the figure, the less energy used.			X	X	X	X
Also adjust the 'Set point digital (0). 50% of 'Set point digital (1)'. Open the extractor hoods		X				X
Open the 2 position valves and the extractor hoods				X		
Check the air volumes through the valves again.	X				X	
Check the underpressure behind the valve furthest from the fan. This must be minimum 50 Pa.			X			
Check the air volumes through the valves and extractor hoods again.		X				X
Check the air volumes through the extractor hoods.				X		
Check the underpressure behind the valve furthest from the fan. This must be minimum 50 Pa.						
Draw up a measuring report.	X	X	X	X	X	X
Set any external regulators back to the correct position	X	X	X	X	X	X



For further information, see:
J.E. VENT-AXIA Ventilation systems Residential Information, 'Adjustment instructions' tab sheet.

12. EC statement

J.E. Stork Ventilatoren b.v.
P.o. box 621
8000 AP Zwolle-NL
Commercial Register Zwolle 22293

EU-declaration of conformity

Machine description	:	MX10/10; MX20/20; MX30/10; MX30/20
EU-Type examination	:	- Not applicable
- Number	:	:
- Name of notified body	:	:
- Address	:	:
Conforms the following directives	:	- Machinery Directive (98/37/EC) - Low voltage Directive (73/23/EC) - EMC Directive (89/336/EEC, 92/31/EEC and 93/68/EEC)
Conforms with harmonized standards	:	- EN 292-1 (1991) "Safety of machinery" - EN 292-2 (1991) "Safety of machinery" - EN 414 (1992) "Safety of machinery" - EN 60034-5 (1986) "Classification of degrees of protection provided by enclosures for rotating machinery" - EN 60335-1 (1995) "Safety of household and similar electrical appliances" - EN 50178 (1997) "Electronic equipment for use in power installations" - EN 55014-1 (1997) "Requirements for household appliances, electric tools and similar apparatus. (Part 1: Emissions)" - EN 55014-2 (1997) "Electromagnetic compatibility (EMC) Immunity requirements for household, powertools and similar apparatus" - EN 61000-3-2 (1995/A1:1998) "Electromagnetic compatibility (EMC) –Part 3: Limits; Section 2: Limits for harmonic current emissions" - EN 61000-3-3 (1997) "Limitation of voltage fluctuations and flicker in low voltage supply systems for equipment with rated current less than of equal to 16A"
Conforms with national standards	:	:
Conforms with international standards	:	:

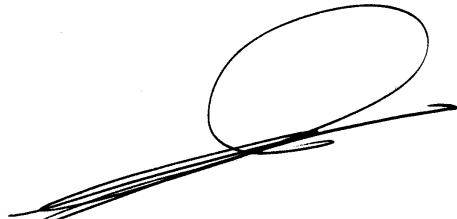

Zwolle, October 20th, 2000

P. Jansen
Managing Director

