

Vent-Axia[®]
Clean Air Systems

HR100W, HR100WH & HR30W

Through The Wall Heat Recovery Ventilators

Installation and Servicing Instructions

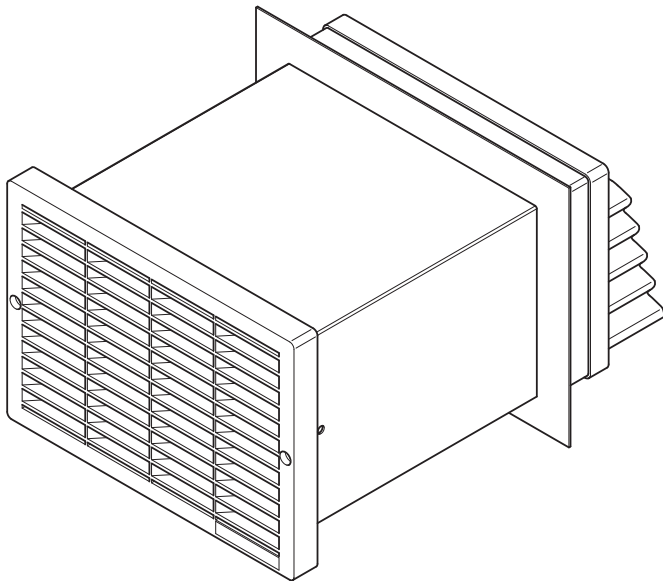



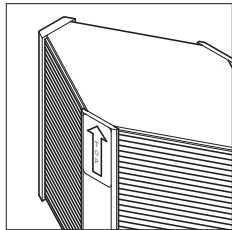
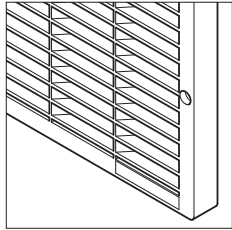
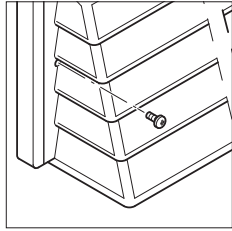

Contents

Section	Page
1.0 Introduction	4
2.0 Site Requirements	5
3.0 Installation	6
4.0 Electrical	8
5.0 Maintenance	9
6.0 Additional Information	11
7.0 Fixing Template	12

1.0 Introduction

1.1 Description

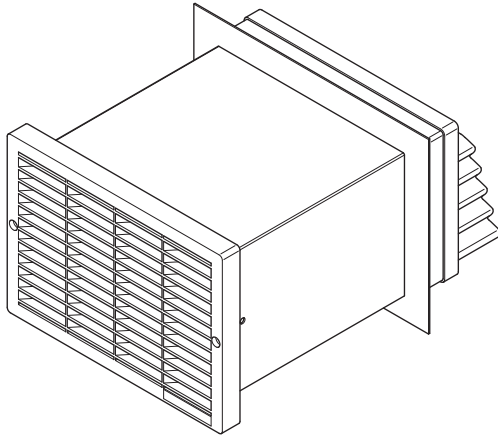

Fig. 1

1. The HR100W, HR100WH and HR30W units are "through the wall" heat recovery ventilators, for use in areas such as kitchens, bathrooms and single occupancy bedrooms.

2. The units are fitted with twin impeller and heat exchanger arrangements which simultaneously supply and extract air while transferring heat from the stale exhaust airflow to the fresh intake airflow. This provides up to 70% heat recovery from the stale extracted air. A boost speed facility is available for periods when higher air change rates are required.

3. Installation and maintenance for all three units is the same, therefore the majority of this booklet is based on the standard HR100W unit (Fig. 1). For additional information on the other units, please refer to Additional Information (Section 6.0).

2.0 Site Requirements

2.1 Information

1. The unit is designed for installation in external walls with a thickness of up to 280mm (Fig. 3). For wall thicknesses above 280mm, an extension kit (Ref. EXT100) must be used.

2. The unit must be sited and connected by a suitably qualified person and be in accordance with current U.K. Building Regulations and I.E.E. Wiring Regulations (BS 7671).

3. The unit is intended for permanent connection to the mains electrical supply.

4. The unit is intended for fixed wiring installation.

5. Ensure that the mains electrical supply is compatible with the product's rating label.

6. The unit must be sited away from direct sources of heat in excess of 40°C.

7. Do not site the appliance in the vicinity of excessive levels of airborne oil or grease.

8. If the unit is installed in a room containing a fuel burning appliance, the installer must ensure that air replacement is adequate for both appliances.

9. The internal grille surround must be sited a minimum of 125mm away from any wall or projecting surface (Fig. 2).

10. The external cowl of the unit must be sited a minimum of 500mm away from the flue of gas or open fire appliances. This is to avoid back flow of gases entering the room.

11. All safety regulations and requirements must be strictly followed to prevent hazards to life and property both during and after installation and during subsequent maintenance or servicing.

12. Ensure the mains electrical supply is isolated before commencing installation, or maintenance.

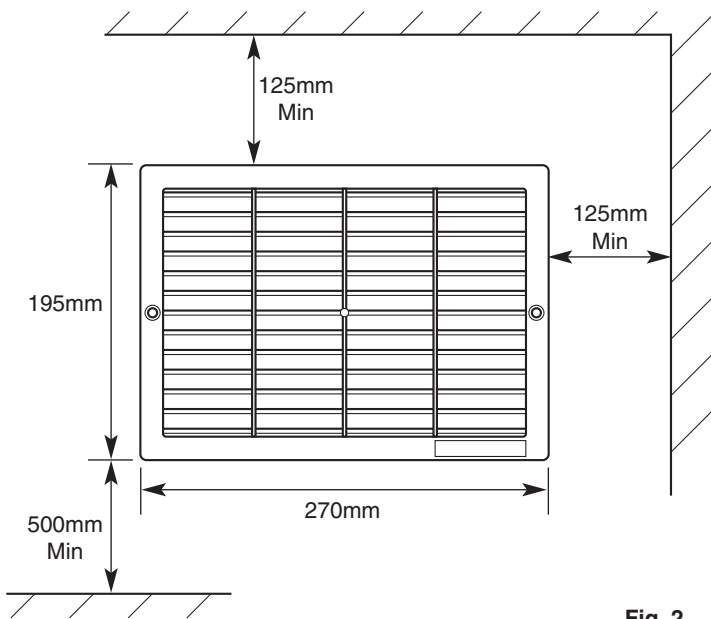

Fig. 2

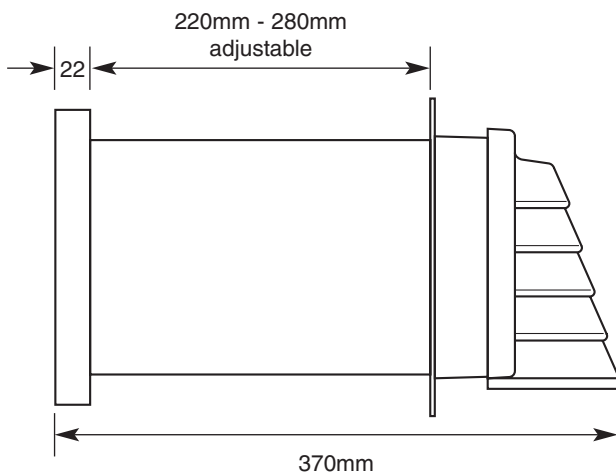

Fig. 3

3.0 Installation

3.1 Controllers

The HR100W unit can be installed in conjunction with a number of controllers.

VCON100

The VCON100 is a dedicated controller, suitable for ON/OFF and two speed control of the HR100W unit only.

PCSW

The PCSW is a pullcord switch, suitable for manual switching between HIGH and LOW speeds of the HR100W and HR100WH units.

NBSW

The NBSW is a manual switch for switching between HIGH and LOW speeds of the HR100W and HR100WH units.

HS6

The HS6 is a humidity sensor for switching between HIGH and LOW speeds during the daytime according to relative humidity levels.

TIM2

The TIM2 is an overrun timer which can also be used to control the HR100W unit via a light switch or remote sensor e.g. PIR detector.

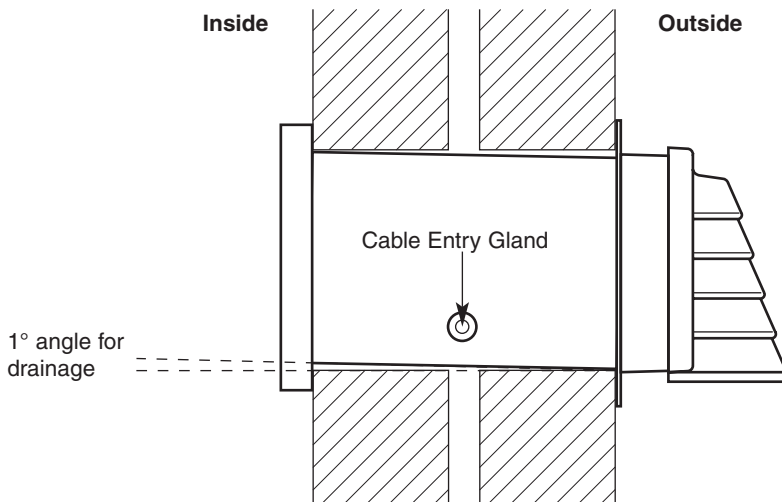

Fig. 4

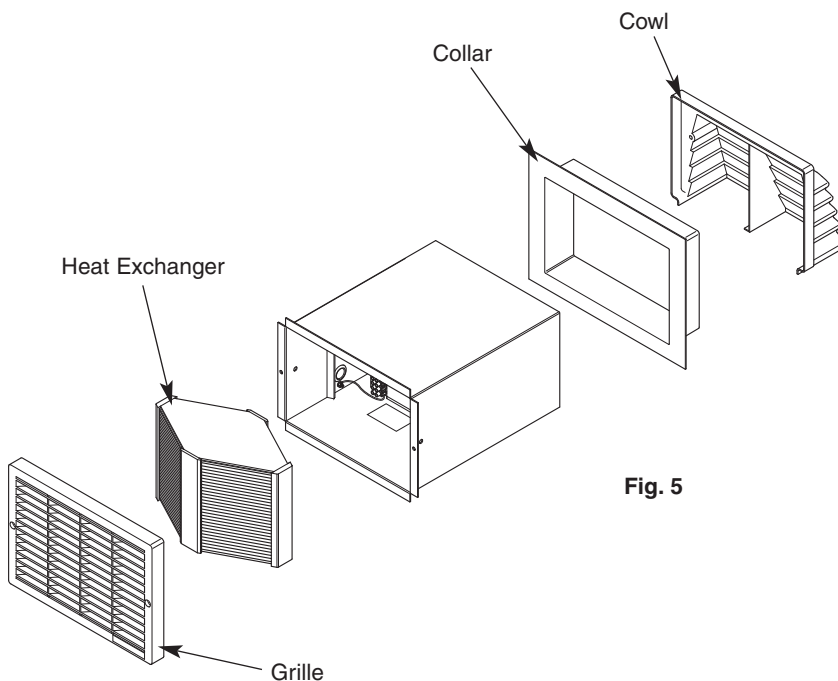

Fig. 5

3.2 Initial Preparation

1. Select an approved electrical control arrangement for the HR100W unit (above).
2. After considering the site requirements (page 5), select a suitable site for the unit and controllers and work out the cable runs.

WARNING: Before deciding on the final position for the unit, check there are no buried cables, pipes or obstructions on the outside wall.

Cable requirements:
Three core for single speed operation.
Four core for two speed operation.
See page 8 for wiring options.

3. Install the cable runs and appropriate controllers in conjunction with a fused connection unit. Contact gap must not be less than 3mm.
4. Working from the inside, mark out the position of the mounting hole - 240mm wide x 160mm high (see Fixing Template - page 11).
5. Carefully cut the holes in the inner and outer brick courses to form a suitable aperture to receive the unit. Ensure that this is level, or angled down slightly to outside (Fig. 4).

NOTE: Bricks will cut more easily and accurately if a series of holes are drilled close together along the marked lines.

6. Remove the grille, heat exchanger, outer collar and cowl from the unit (Fig. 5).

3.0 Installation

3.3 Installing the Appliance

From inside

1. Slide the unit into the mounting hole and ensure that the rear of the mounting flange can be set flush with the internal wall finish (Figs. 6 & 7).

NOTE: The HR100W units have a maximum overhang on the outside of 60mm. If the overhang exceeds 60mm, the unit must be pushed inwards until the maximum overhang is achieved.

2. Feed the power supply cable through the gland (Fig. 6).

3. Ensure that the unit is square and true with the outside wall face. If firmer fixings are required, secure the unit in place with the two fixing screws provided (Fig. 7).

4. Make good around the case.

From outside

1. With the cowl removed, slide the collar (flange first) on to the unit and press the flange firm against the outer wall (Figs. 8 & 9).

2. Mark and trim the small end of the collar flush with the metal casing of the unit (Fig. 9).

3. Make good between the face of the flange and the wall using an appropriate waterproof mastic seal.

4. If firmer fixings are required, secure the flange to the wall using plugs and screws (Fig. 8).

5. Fit the cowl in place and secure using the two screws provided (Fig. 9).

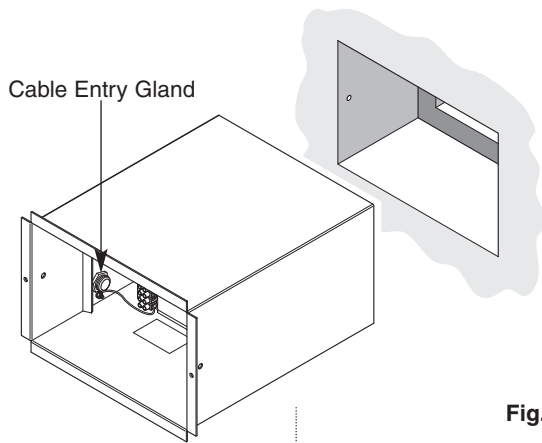

Fig. 6

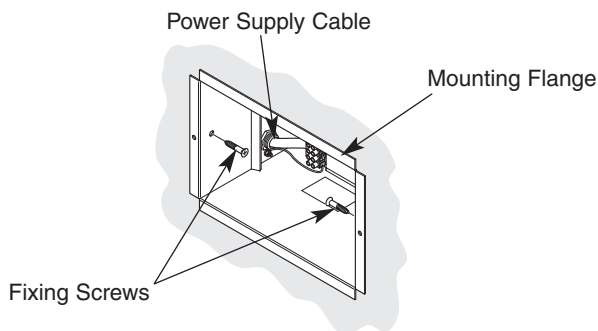

Fig. 7

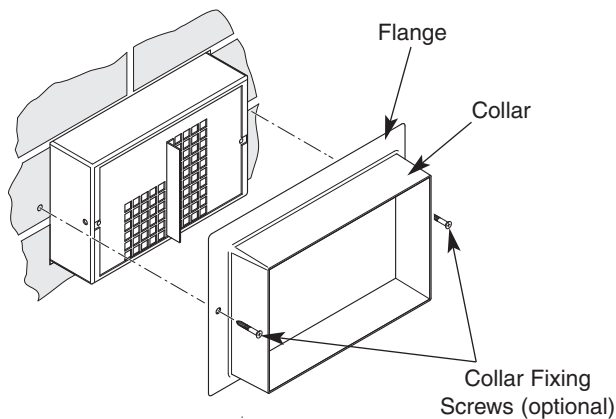

Fig. 8

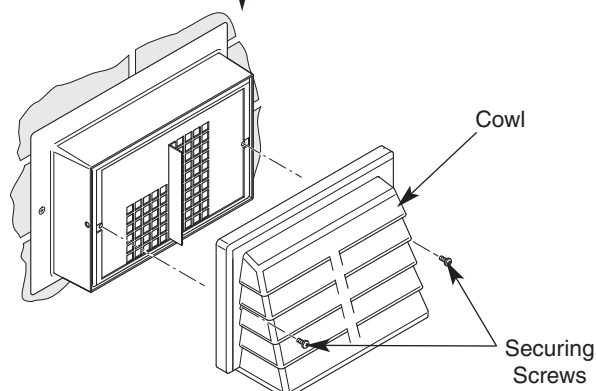

Fig. 9

4.0 Electrical

4.1 Electrical Connections

230V 50Hz 12W (normal) 31W (boost)

1. The HR100W is supplied with an in-built two speed motor fitted.

2. Wiring must be via a 3A fused switched spur with a 3mm contact separation in each pole. The wiring should be suitably (Basec or Har) approved cable of appropriate current carrying capacity.

3. Ensure that the mains power supply is isolated prior to installation.

4. Remove the terminal block cover (Fig. 10) and connect incoming wires to the appropriate terminals, see relevant wiring diagram (for HR100WH see page 11).

5. Replace the terminal block cover and tighten the cable gland (Fig. 10).

6. Slide the heat exchanger into the unit, ensuring the 'Top' label is facing the front and pointing upwards (Fig. 11).

7. Locate the grille on to the front of the unit and secure with the two screws provided (Fig. 11).

8. Switch on the mains electrical supply and check the operation of the unit.

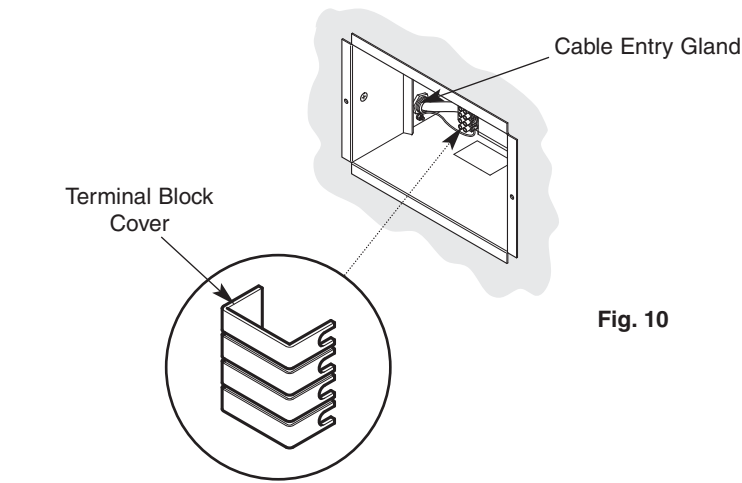

Fig. 10

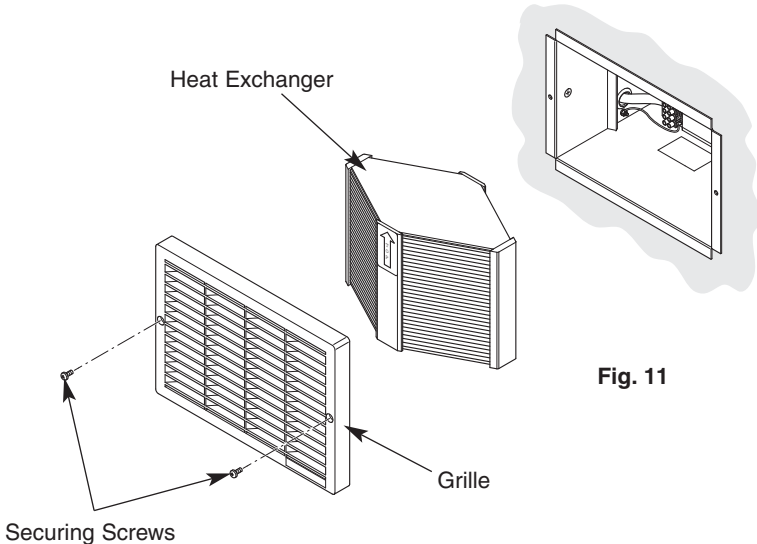
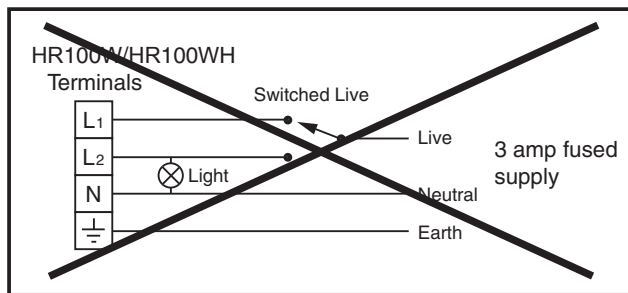

Fig. 11

HR100W, HR30W and HR100WH units must not be wired in conjunction with a light switch, units will fail.



HR100W continuous normal speed.

HR100W Terminals 3 amp fused supply

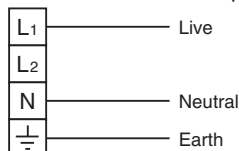

HR100W continuous boost speed.

HR100W Terminals

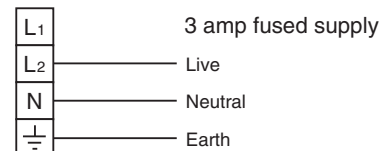

HR100W wiring to VCON100 controller for manual, on/off, normal and boost switching.

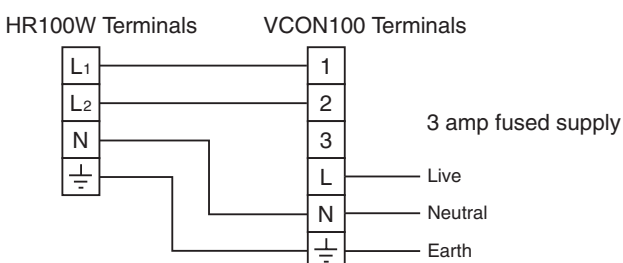

HR100W wiring to NBSW/PCSW switches for manual, normal and boost switching.

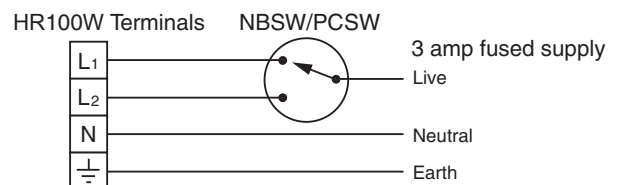

5.0 Maintenance

5.1 Cleaning the Unit

1. In addition to removing odours, providing fresh air and recovering heat, this unit extracts airborne impurities such as dust, dirt and grease. These gradually build up and detract from the efficiency and appearance of the unit.

2. To ensure optimum performance, the unit should be cleaned every three to six months or at periods determined by the level of contamination experienced, and according to the following procedure.

3. Isolate the mains power supply.

4. Undo the two grille securing screws and remove the grille (Fig. 12).

5. Pull the four tubular inserts out of the rear of the grille and remove the filter (Fig. 13).

6. Slide out the heat exchanger (Fig. 14).

7. Wash the grille, filter and heat exchanger in warm water using a mild detergent and dry thoroughly. Keep water away from all electrical components and wiring within the unit. If the filter cannot be cleaned, a replacement is necessary (Part No. HR100RF4).

8. Reassemble in reverse order ensuring that the filter and inserts are seated correctly in the grille. The heat exchanger should be repositioned with the 'Top' label facing the front and pointing upwards.

9. Switch the power supply on and check the operation of the unit.

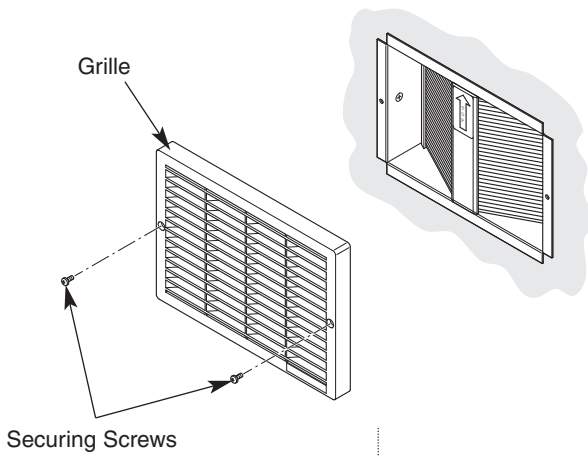

Fig. 12

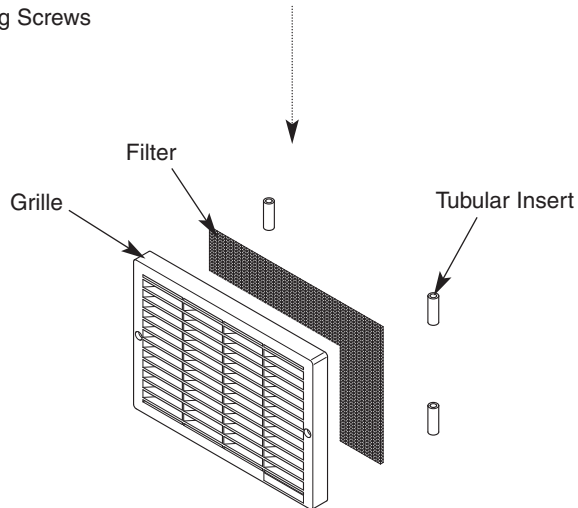

Fig. 13

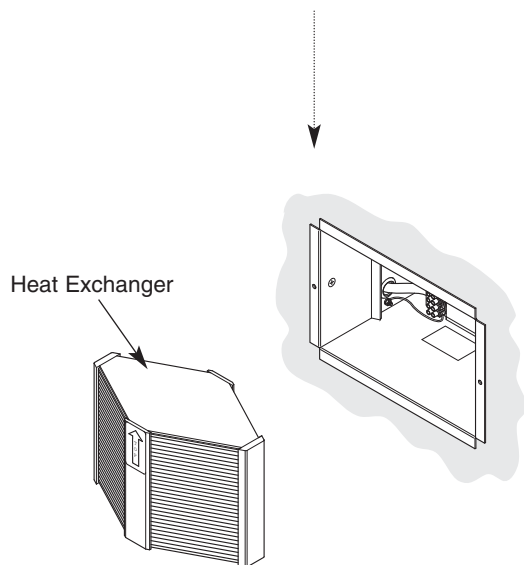

Fig. 14

The unit is supplied with four, 6-month Timestrip indicators. A Timestrip is a single use self-adhesive label that once activated will turn red over 6 months. It should be used to keep track of when the filter and cell need cleaning/replacement. Using the self-adhesive backing the strip can be stuck near the units controls, or in a easily visible place.

A normal cleaning schedule for a unit would be as follows:

After installation	Activate the 1st Timestrip
After 6 months	Clean cell, clean filter, activate 2nd Timestrip
After 12 months	Clean cell, clean filter, activate 3rd Timestrip
After 18 months	Clean cell, clean filter, activate 4th Timestrip
After 24 months	Clean cell, replace filters , the new filters will be supplied with 4 additional Timestrip indicators

Note: The above is the minimum requirement; more frequent cleaning intervals may be needed depending on the environment the unit is installed in.

Activating the Timestrip.



1. Activation: Fully squeeze the activation button between thumb and finger. A red line will appear within 1-2 minutes to show that the Timestrip has been activated.
2. Peel off the backing liner and stick the Timestrip to the Unit or near the controls of the unit. The location should make it obvious to the person responsible for maintenance that the unit needs attention.
3. Once activated, the red dye will indicate elapsed time by moving through the white window and past each time marker. The progress of the red dye is irreversible and each Timestrip can only be used once.

6.0 Additional Information

6.1 HR100WH

1. The HR100WH unit is fitted with an adjustable humidity sensor.
2. It is factory set to automatically switch to BOOST speed at approximately 70% Relative Humidity at 20°C.
3. To adjust this setting, remove the grille and slide out the heat exchanger (see page 9).
4. The adjustment spindle is positioned on the front of the motor housing (Fig. 15).
5. Turn the spindle clockwise (+) to raise the set point, making the unit BOOST at a higher Relative Humidity.
6. Turn the spindle anticlockwise (-) to lower the set point, making the unit BOOST at a lower Relative Humidity.
7. Reassemble the unit in reverse order.

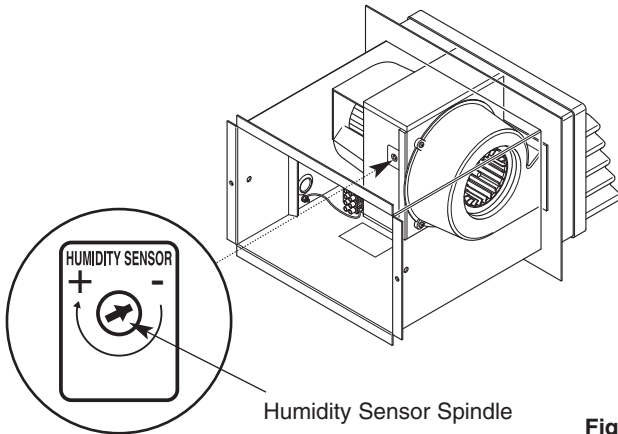

Humidity Sensor Spindle

Fig. 15

HR100WH automatic speed control.

HR100WH Terminals 3 amp fused supply

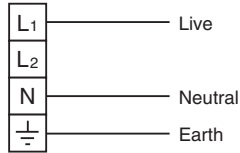

HR100WH manual/normal/boost override using a 2 way switch - NBSW or PCSW.

HR100WH Terminals NBSW/PCSW

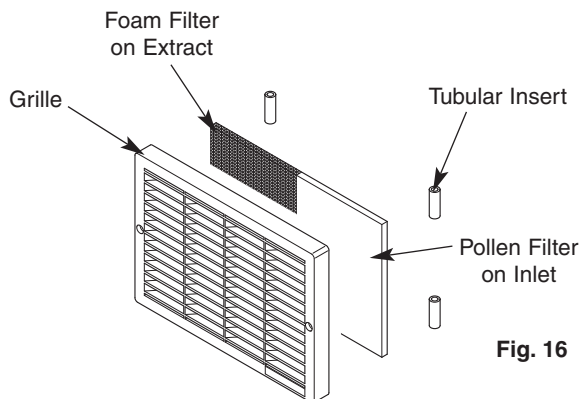
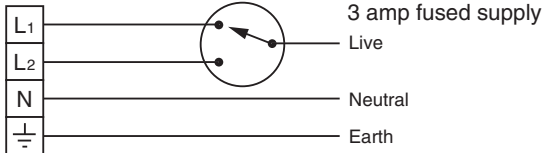
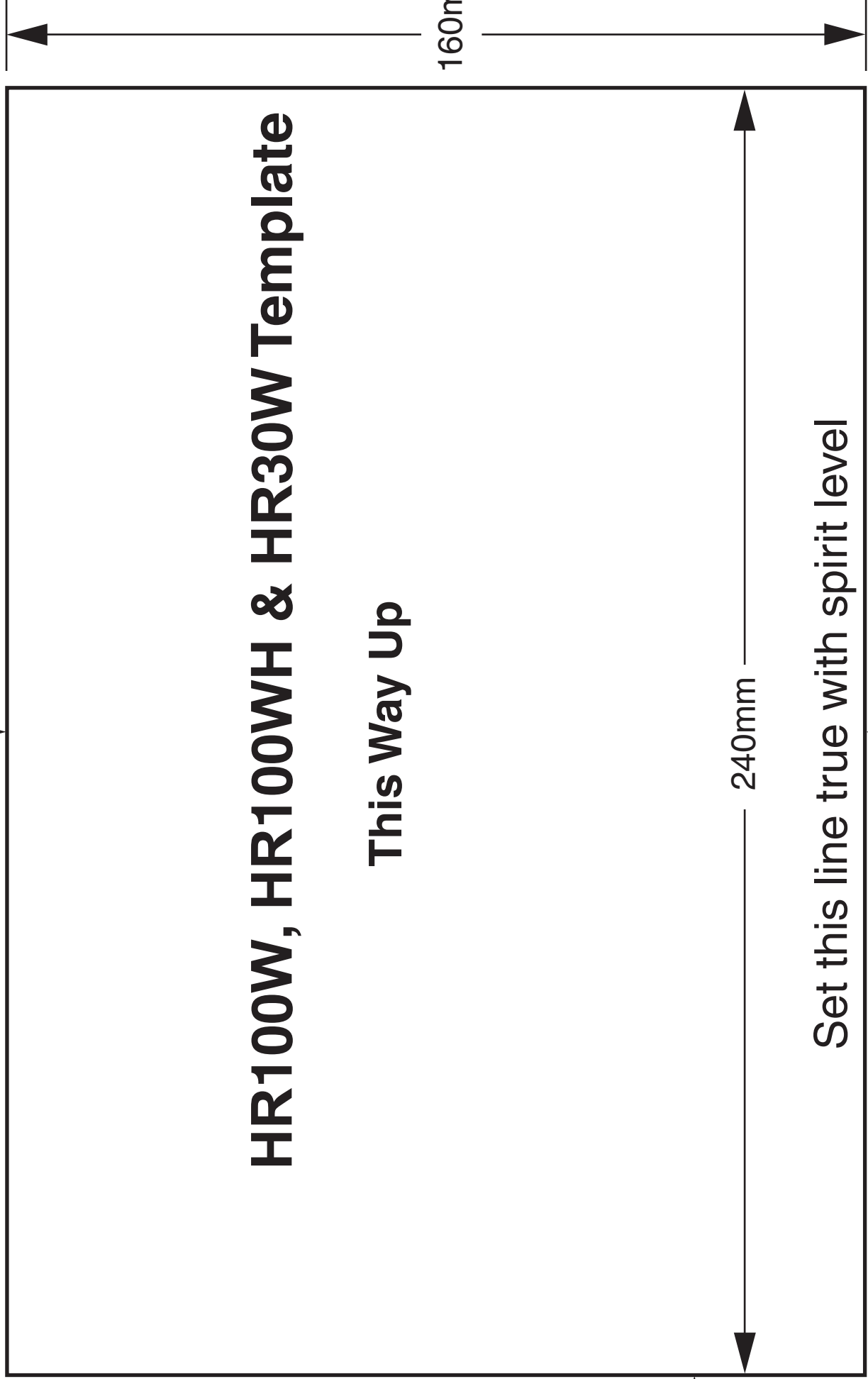

Fig. 16

6.2 HR30W

1. The HR30W unit is fitted with an extra fine pollen filter (Part No. HR30RF4). This should be maintained in the same way as the standard filter, see Cleaning the Unit (section 5.0).

125mm minimum
distance from ceiling



This Way Up

HR100W, HR100WH & HR30W Template

Set this line true with spirit level

Cable
Entry



160mm

240mm

500mm minimum
distance from floor

NOTES:-

NOTES:-

NOTES:-

Vent-Axia[®]
Clean Air Systems

A Division of Vent-Axia Limited
Fleming Way, Crawley, West Sussex RH10 9YX
Technical support:- 01293 526062 Fax:- 01293 539209
Internet site at:- www.vent-axia.com