



## Contents

Section	Page
<b>1.0 User Information</b>	<b>3</b>
<b>2.0 General Layout</b>	<b>6</b>
<b>3.0 Technical Data</b>	<b>8</b>
<b>4.0 Appliance Operation</b>	<b>10</b>
<b>5.0 Installation Requirements</b>	<b>11</b>
<b>6.0 Installation</b>	<b>14</b>
<b>7.0 Wiring Diagrams</b>	<b>18</b>
<b>8.0 Commissioning</b>	<b>22</b>
<b>9.0 Maintenance</b>	<b>24</b>
<b>10.0 Changing Components</b>	<b>26</b>
<b>11.0 Fault Finding</b>	<b>30</b>
<b>12.0 Short Parts List</b>	<b>35</b>

## 1.0 User Information

The WH204 (Fig. 1) and WH205 (Fig. 2) are whole house ventilation units.

This appliance must be installed in accordance with the manufacturers' instructions and the regulations in force.

Duct systems must be installed in accordance with CIBSE guides and BRE Digest 398.

Read the instructions fully before installing or using the appliance.

**Warning :** The ventilation for any open flued appliance must always be considered before siting the extract and inlet vents, the vents must also be sited away from other flue terminals, ventilators etc. on the outside of the dwelling. In addition there shall be adequate ventilation of the room when the cooker hood is used at the same time as appliances burning gas or other fuel. The exhaust air duct must not be discharged into a flue which is used for exhausting fumes from appliances burning gas or other fuels. Refer to the relevant current British Standard Codes of Practice, Part J of the Building Regulations England and Wales and Part F of the Building Standards (Scotland) Regulations.

WH204

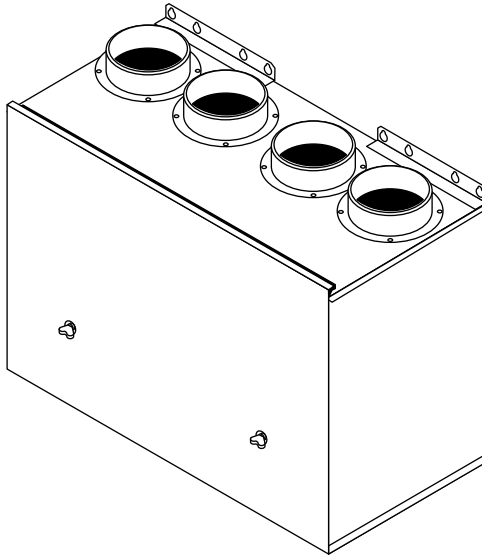

Fig. 1

WH205

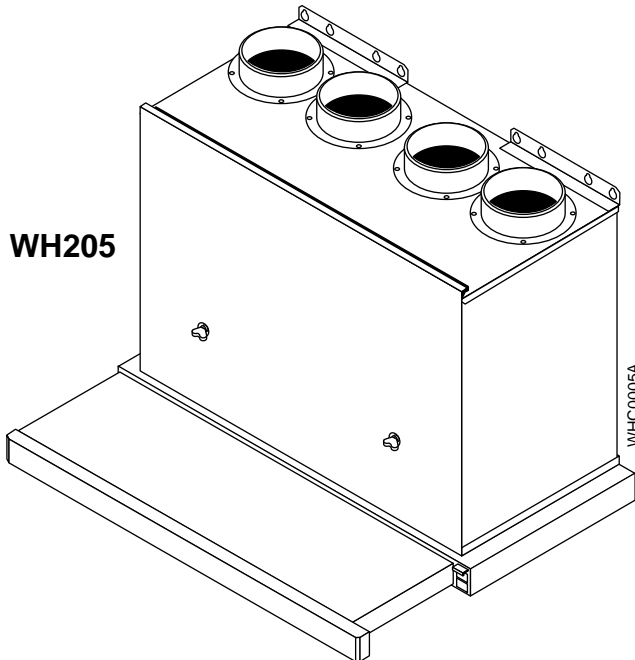
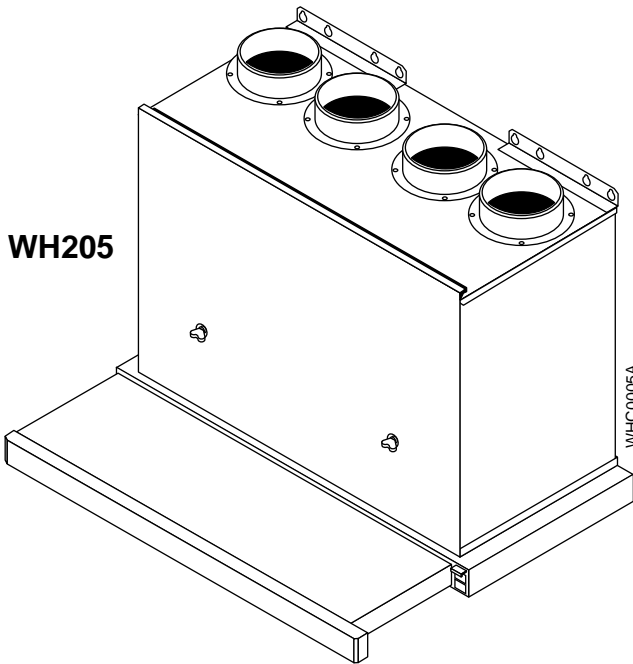
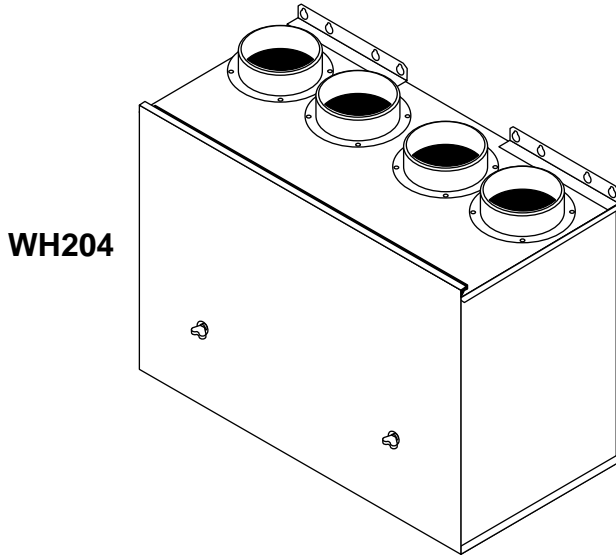

Fig. 2

## 1.0 User Information



- **WH204**

**Important: The WH204 is not suitable for installation above any cooking appliance.**

The WH204 is a mechanical ventilation with heat recovery (MVHR) unit. The unit provides continuous extraction of stale air from the dwelling typically from the bathroom and from the kitchen. The stale air passes through the heat exchanger before being ducted to outside.

Fresh air from the outside is continuously drawn into the unit and passed through a filter and then into the heat exchanger. In the heat exchanger the fresh air is pre-warmed and ducted into the dwelling typically to living rooms/ bedrooms.

- **WH205**

The WH205 is a mechanical ventilation with heat recovery (MVHR) unit, designed solely to operate with the Vent-Axia telescopic cooker hood. The unit provides continuous extraction of stale air from the dwelling typically from the bathroom and the kitchen. The stale air passes through the heat exchanger before being ducted to outside.

Fresh air from the outside is continuously drawn into the unit, passed through a filter and then into the heat exchanger. In the heat exchanger the fresh air is pre-warmed and ducted into the dwelling typically to living rooms/ bedrooms.

When the telescopic hood is extended the MVHR unit switches automatically to boost. The hood draws steam and fumes from cooking through metal filters and direct to outside.

**Important: The cooker hood must always be fully opened when the cooker /hob is in use.**

**Warning: Do not flambé under the cooker hood**

## 1.0 User Information

### Cleaning the Unit

**Warning: Disconnect from mains electrical supply before cleaning any components.**

**Note: It is important that any door or cupboard front covering the MVHR unit is easily removable by the user as access for regular cleaning of the air filters and heat exchanger is required.**

**Warning: Failure to clean the cooker hood and its filters as described below will lead to a fire risk.**

**The cooker hood and filters should be checked and cleaned every 3 months.**

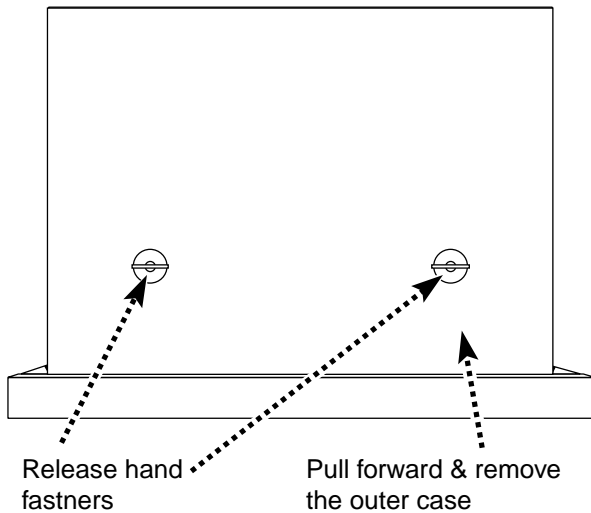

Fig. 3

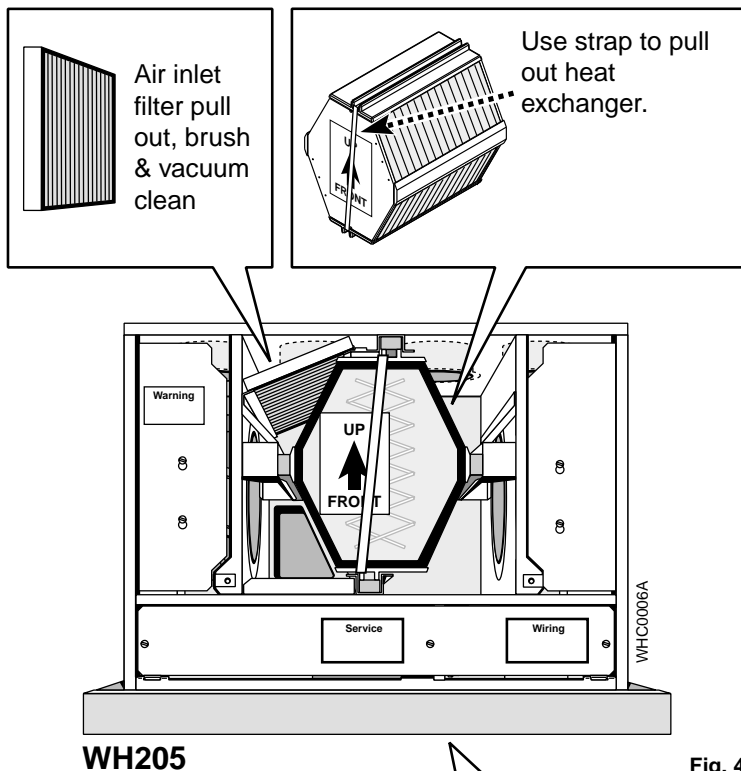

Fig. 4

### 1.1 Heat Exchanger - WH204 & WH205

1. Lift off the front door panel by releasing the two hand screws and lifting upwards.
2. Note how the heat exchanger is fitted and by using the plastic strap pull forwards to remove.
3. If necessary the heat exchanger can be washed in warm water using a mild detergent. Take care not to damage the fins. Re-assemble in reverse order after thoroughly drying.

### 1.2 Air Inlet Filter - WH204 & WH205

Fig. 4

1. Lift off the front door panel by releasing the two hand screws and lifting upwards.
2. Remove the air inlet filter by pulling forwards.
3. Carefully brush and vacuum the filter in a well ventilated area.
4. Re-assemble in reverse order.

### 1.3 Cooker Hood Filters - WH205

Fig. 5

1. Rear Filter - To remove the rear filter grip and pull inwards the grey handles at either side and slide the filter forwards and downwards.
2. Front Filter - To remove the front filter grip and pull inwards the grey handles at either side and drop the filter downwards.
3. The filters can be washed in a dishwasher or in warm soapy water. Thoroughly dry the filters and re-assemble in reverse order.

**Note: For spare parts see Section 12.**

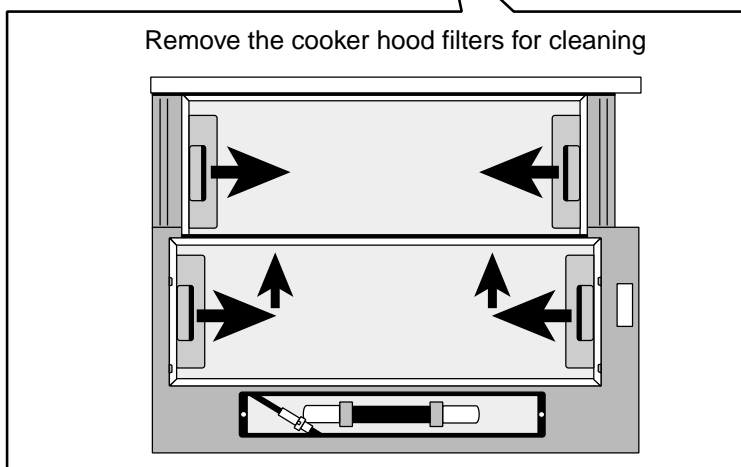

View from below the unit

Fig. 5

## 2.0 General Layout

WH205

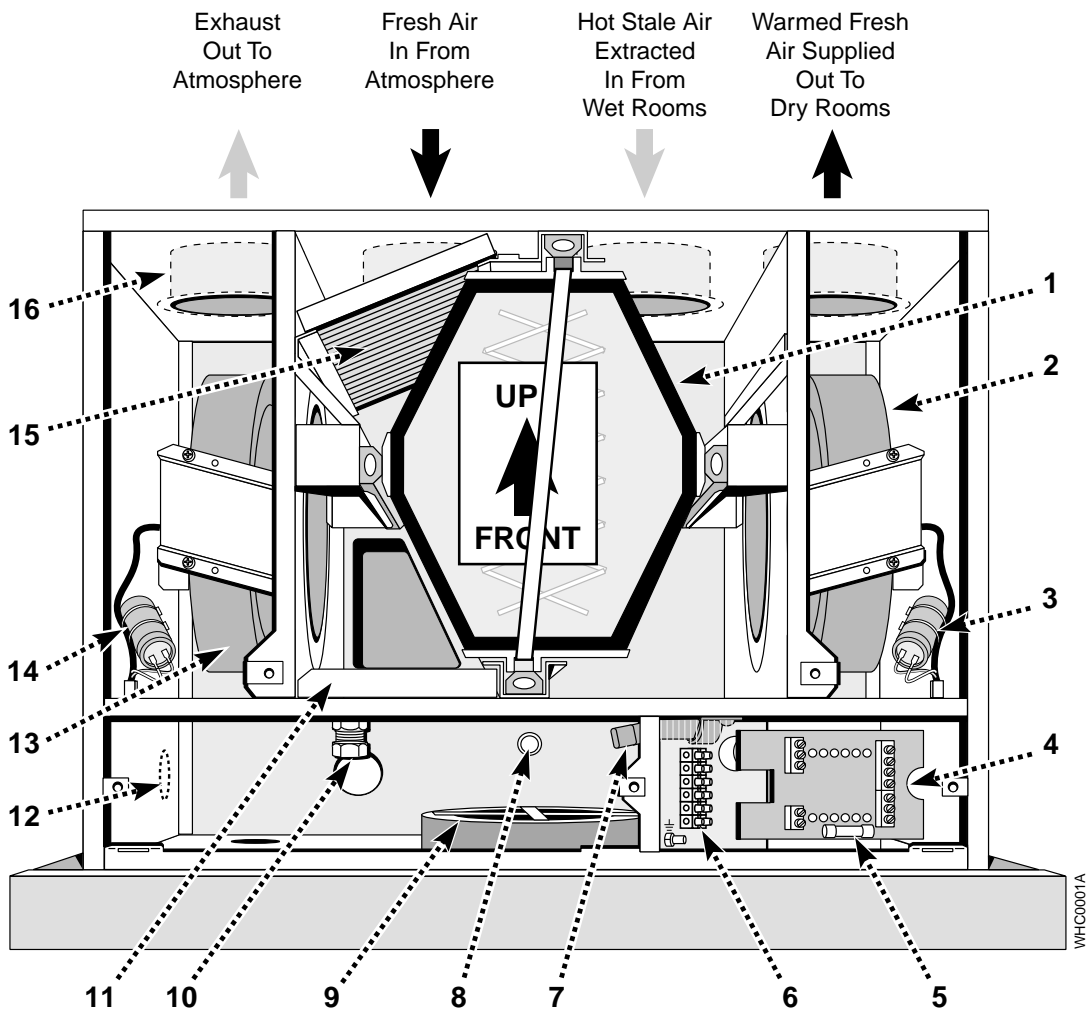

Cover Panels removed for clarity.

- |                                   |                                       |
|-----------------------------------|---------------------------------------|
| 1. Heat Exchanger (Lexan)         | 9. Fire Damper                        |
| 2. Fan (Fresh Air In)             | 10. Condensate Drain (15mm)           |
| 3. Fan Capacitor (RH)             | 11. Condensate Tray                   |
| 4. Electrical Control/Transformer | 12. Alternative outlet for condensate |
| 5. Fuse (3.15amp fast blow)       | 13. Fan (Extraction)                  |
| 6. Terminal Block                 | 14. Fan Capacitor (LH)                |
| 7. Overheat Sensor                | 15. Inlet Air Filter                  |
| 8. Lower Fixing Hole              | 16. Air Connections (4 off)           |

Fig. 6

## 2.0 General Layout

WH204

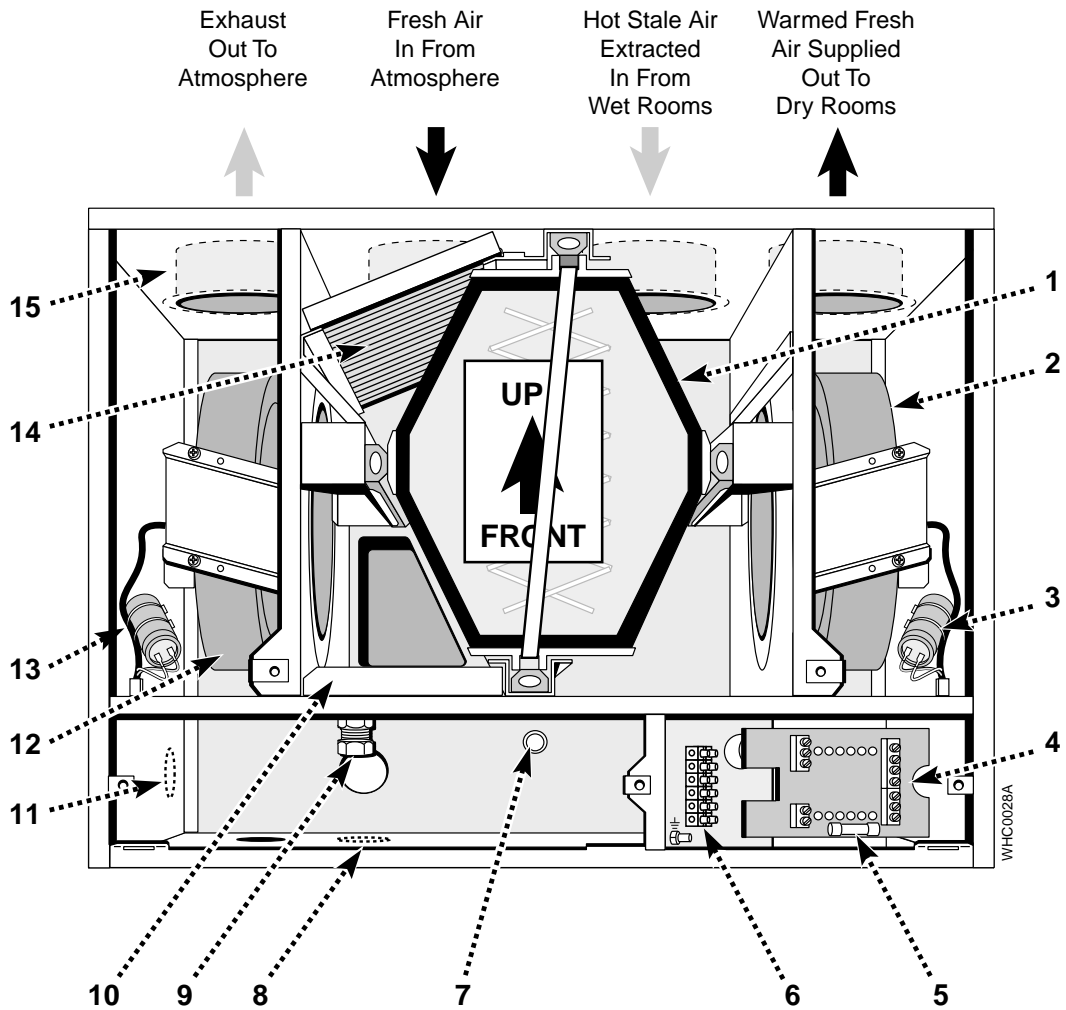

Cover Panels removed for clarity

- |    |  |     |  |
|----|--|-----|--|
| 1. | Heat Exchanger (PVC)                       | 9.  | Condensate Drain (15mm)                  |
| 2. | Fan (Fresh Air In)                         | 10. | Condensate Tray                          |
| 3. | Fan Capacitor (RH)                         | 11. | Alternative outlet for condensate (side) |
| 4. | Electrical Control/Transformer             | 12. | Fan (Extraction)                         |
| 5. | Fuse (3.15amp fast blow)                   | 13. | Fan Capacitor (LH)                       |
| 6. | Terminal Block                             | 14. | Inlet Air Filter                         |
| 7. | Lower Fixing Hole                          | 15. | Air Connections (4 off)                  |
| 8. | Alternative outlet for condensate (bottom) |     |  |

Fig. 7

### 3.0 Technical Data

	<b>WH205</b> Including cooker hood	<b>WH204</b>
Dimensions (mm)		
Height	458	412
Width	598	552
Depth	285	285
Min. Clearances (mm)		
Both sides	1	5
Above casing	200	200
Below casing	700	100
Front for servicing	250	250
Front in operation	None	None
Lift weight (kg)	20.6	16.7
Voltage tappings	Power consumption (watts)	
	Lights off	Lights on
80	16	96
100	27	107
120	40	120
140	52	132
160	65	145
230	111	191
Duct connections	All suitable for 100mm circular ducts	
Condensate connection	Suitable for 15mm pipe	
Electrical supply	230v – 50Hz appliance must be connected to an earthed supply	
External fuse rating	3 amps	
Internal fuse rating	Transformer - 3.15 F	
Filtration	EU2	

**Flow Rate Vs Pressure Chart**

The MVHR unit has five normal fan speed settings and one boost setting. The **performance curve chart** gives the ventilation rates at each fan speed setting compared to the pressure drop of the system.

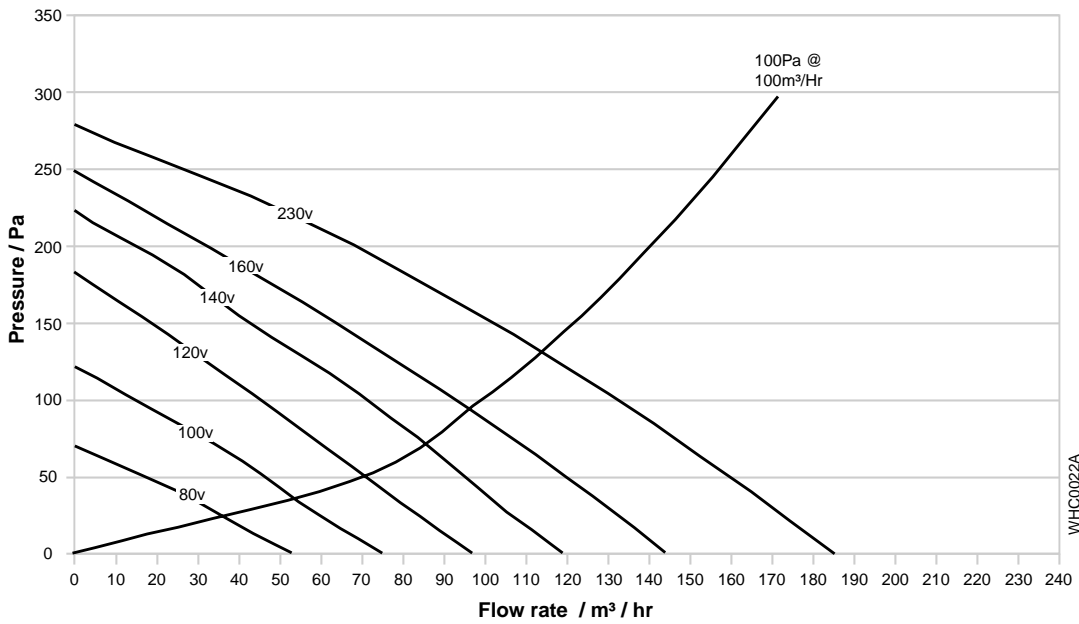

**Fig. 8**

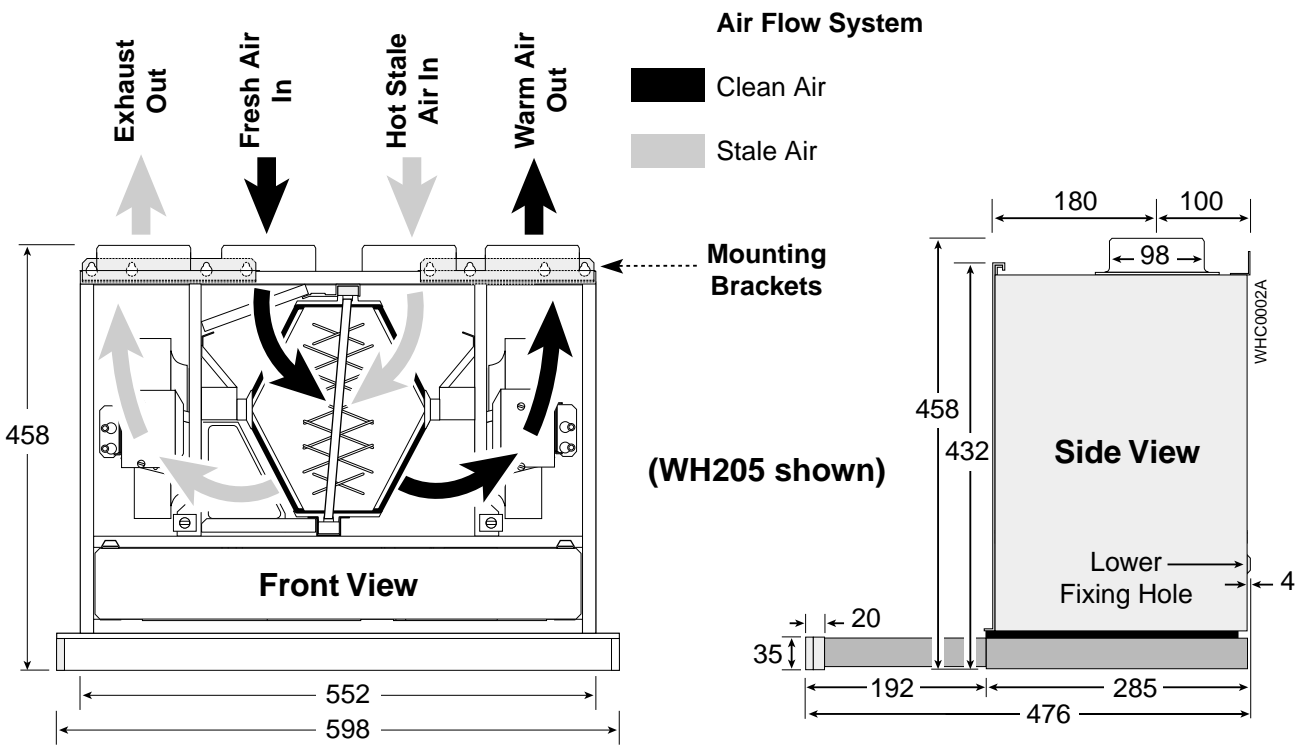

**Fig. 9**

## 4.0 Appliance Operation

### Optional Extras External Controls

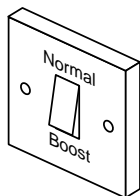

Normal/boost  
Switch  
NBSW

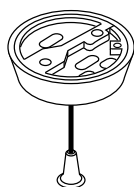

Normal/boost  
Pull Switch  
PCSW

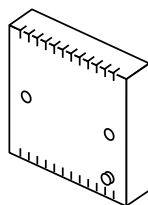

Humidity Sensor  
HS6

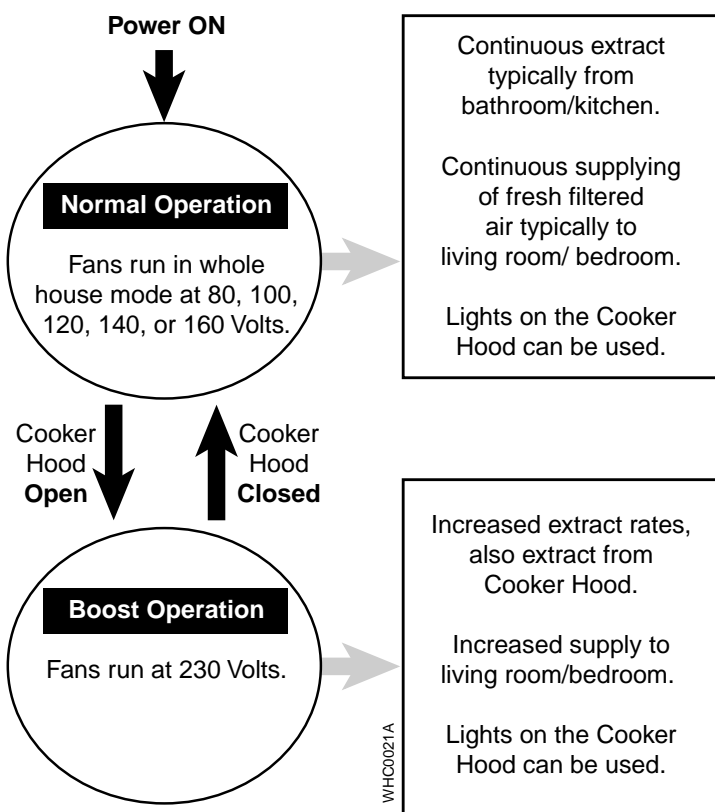

Fig. 10

#### • WH204

When the electricity is switched on the external controls (humidstat or normal/boost switch) supply electricity to the fans.

On normal running the fans run at the voltage set during commissioning (80,100,120,140 or 160 volts).

Air is then moved through the unit (see Fig 8) If the fans become jammed then a thermal trip in the fan senses temperature rise and breaks the electrical supply to the motor. **This can only be reset by disconnecting from the mains supply.**

If the external controls call for boost operation the fans automatically run at 230 volts and increase the air movement of both exhaust and inlet air.

#### • WH205

When the electricity is switched on the unit checks for continuity across the overheat thermostat.

The fans then run at the voltage set during commissioning (80,100,120,140 or 160 volts).

Air is then moved through the unit (see Fig 8) If the fans become jammed then a thermal trip in the fan senses temperature rise and breaks the electrical supply to the motor. **This can only be reset by disconnecting from the mains supply.**

If the overheat thermostat senses an elevated rise in temperature from the cooker/hob it breaks the electrical supply to the fans. **The overheat thermostat can only be reset by disconnecting the mains supply to the unit.**

In the event of a serious fire at the hob (e.g. chip pan fire) the in built fire damper will operate sealing the clean air side of the unit from the fire.

## 5.0 Installation Requirements

### 5.1 Location

1. The cooker hood MVHR unit is only suitable for installation above a domestic cooker or domestic hob. The WH205 must be sited a minimum of 700 mm above the cooker/hob.

2. The exhaust duct must pass through an outside wall or roof and discharge to atmosphere in a suitable position. The clean air inlet duct must pass through an outside wall or roof and be suitably positioned to provide an adequate fresh air supply from atmosphere.

### 5.2 Site requirements

1. For the WH205 a flat vertical area 1332mm high x 600mm wide is required for installation.

For the WH204 a flat vertical area 692mm high x 562mm wide is required for installation.

**Important: The WH204 is not suitable for installation above any cooking appliance or with any extraction system servicing a cooking appliance.**

2. Before installation consideration must be given to the position of the ductwork connections, the electrical connection and the condensate pipe connection.

**Warning: Please check the information on the data plate is compatible with local supply conditions.**

3. The installation must be carried out by a competent person and be in accordance with the relevant Building regulations (Scotland) (consolidation), the Local building regulations, the current I.E.E. Wiring regulations.

Reference should also be made to the BRE digest 398 and CIBSE guidelines.

**Warning: The addition of anything that may interfere with the normal operation of the appliance without the express written permission of Vent-Axia Ltd could invalidate the appliance warranty and infringe regulations.**

**Warning: If the unit is fitted in a room containing a bath or shower then reference should be made to the current I.E.E. Wiring Regulations and Building Regulations.**

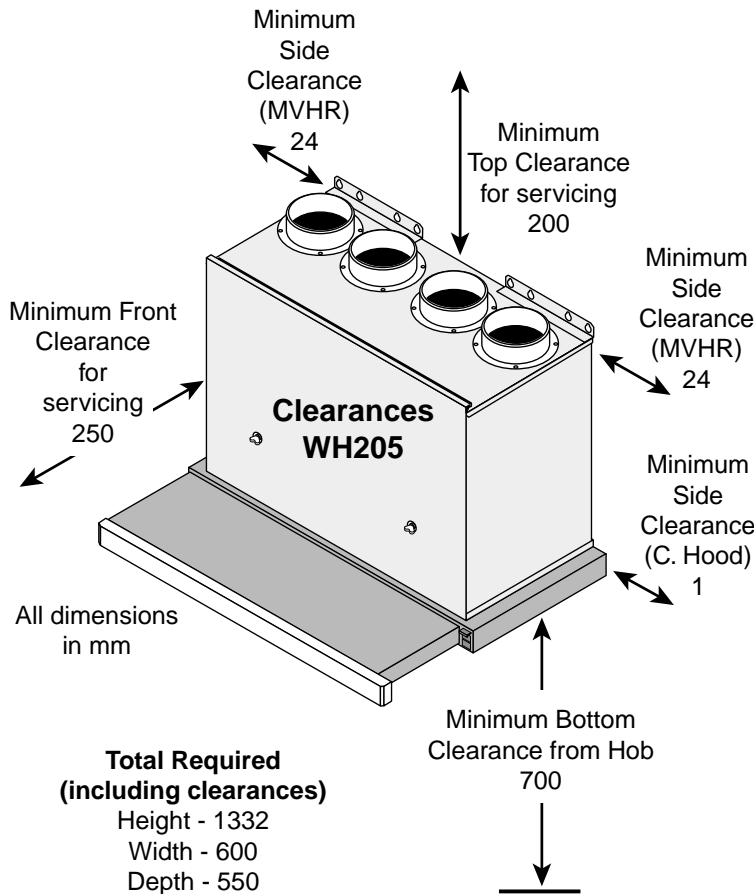

Fig. 11

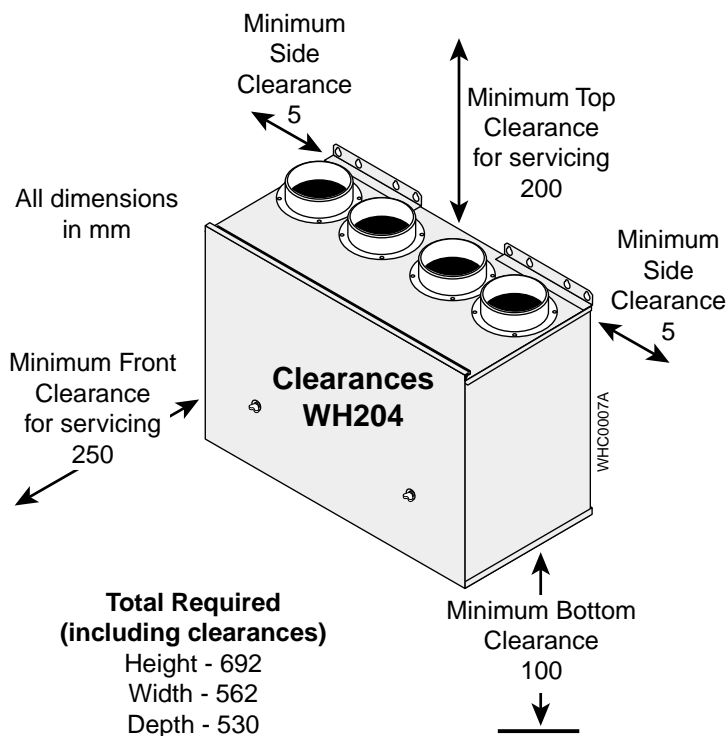

Fig. 12

## 5.0 Installation Requirements

### 5.3 General

1. The MVHR unit has five normal fan speed settings and one boost setting. The **performance curve chart** (Section 3, Fig. 8) gives the ventilation rates at each fan speed setting compared to the pressure drop of the system.

2. The transmission of noise along ducts should be reduced by fitting noise attenuation ducts Part No. **FS100**.

### 5.4 Ducting

1. The outside exhaust duct and outside air intake duct should be sited a minimum of 1 metre apart to minimise the risk of contaminated air being drawn into the house.

2. The duct work system should be sized and installed to minimise the pressure loss along it.

3. Using larger diameter pipes and keeping the number of bends and fittings used to a minimum will reduce the pressure drop and allow the unit to be set at a lower fan speed.

4. Ducting should be insulated in cold areas to minimise heat losses. All duct joints should be suitably taped to ensure an air tight seal.

### Examples of different ducting & fittings

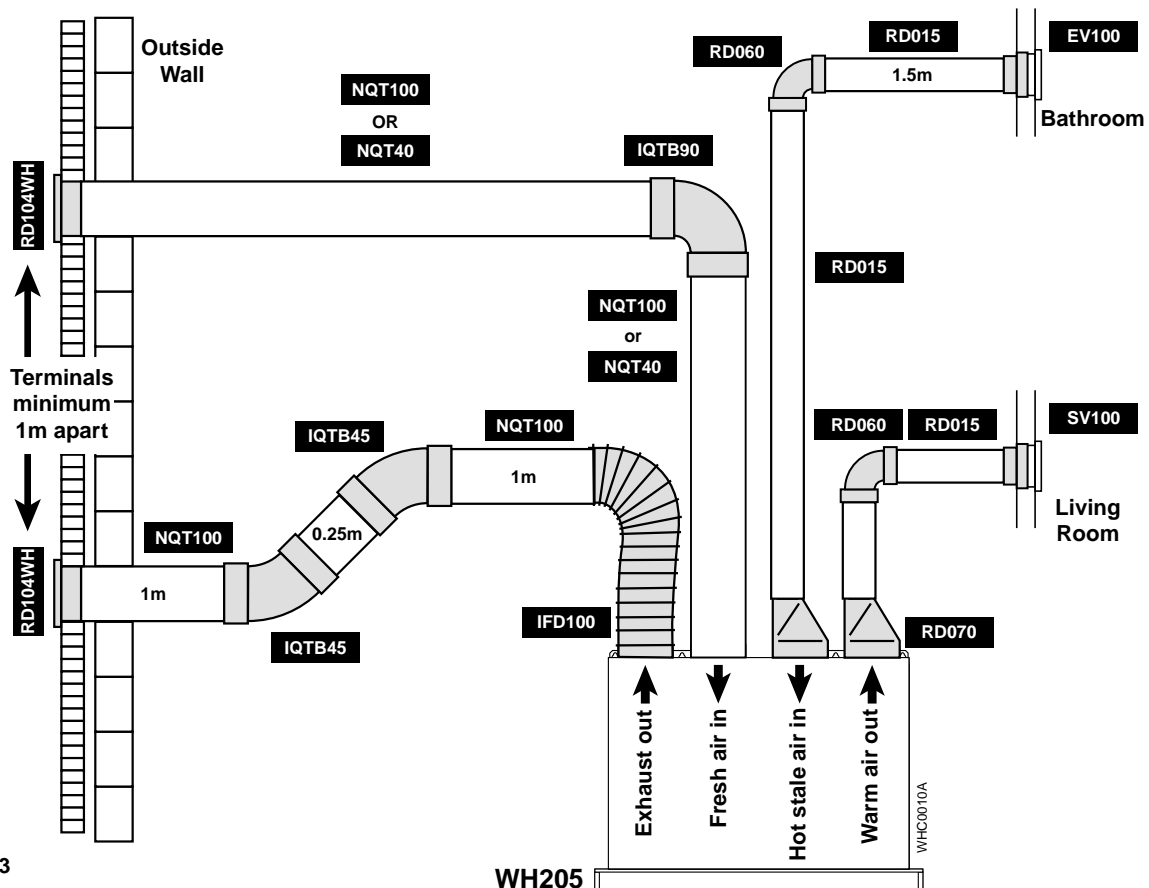

Fig. 13



## 6.0 Installation

### 6.1 Preparation

1. Check site requirements (Section 5) before commencing.

2. Remove the fixing template from the MVHR carton.

After considering the site requirements position the template on the wall ensuring it is level.

3. Mark the positions of at least two top fixing holes, the lower fixing hole and the condensate outlet.

If required mark off the positions of the four duct connections.

4. Drill and plug the wall at the fixing points and drill the condensate hole.

5. The top two screws should now be fitted leaving enough space for the keyhole fixing slots to engage.

6. Place the MVHR unit on its back (Fig. 15). Lift off the front door panel by releasing the two hand screws and lifting upwards.

7. Remove the bottom electrical cover by releasing the 3 screws, pulling the panel forwards and disconnecting the earth lead to the panel.

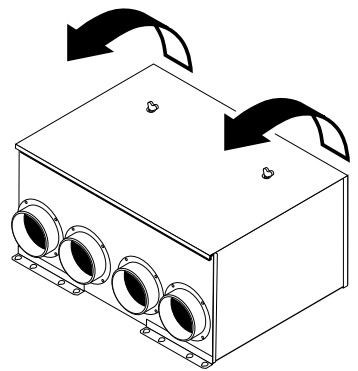
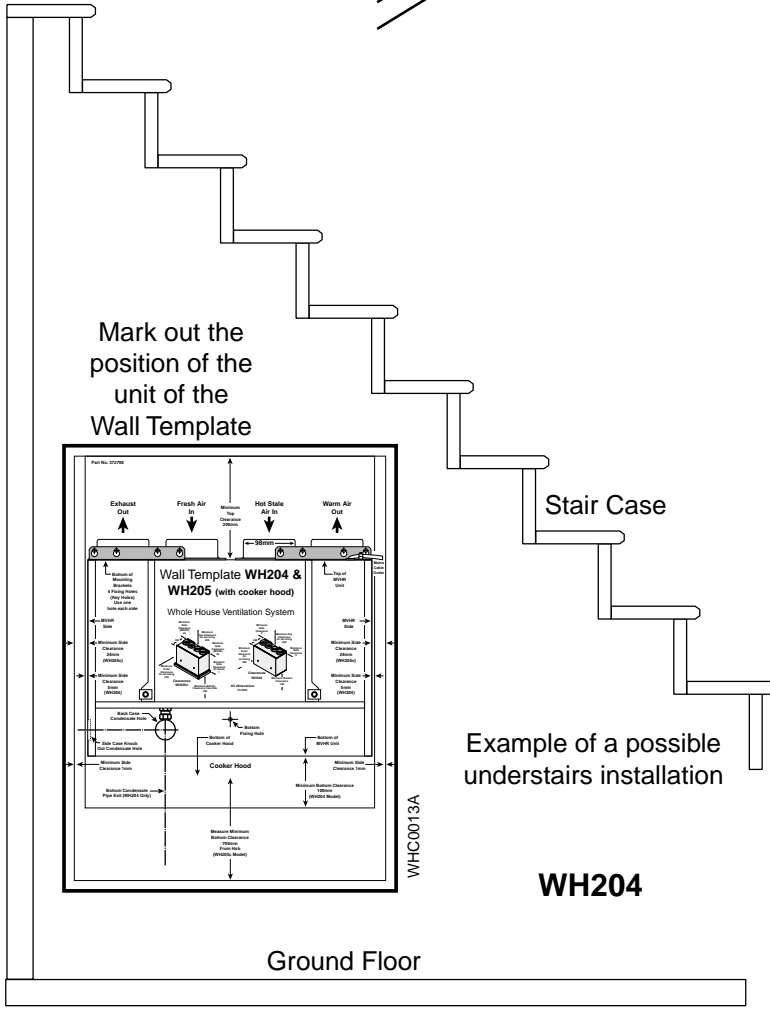
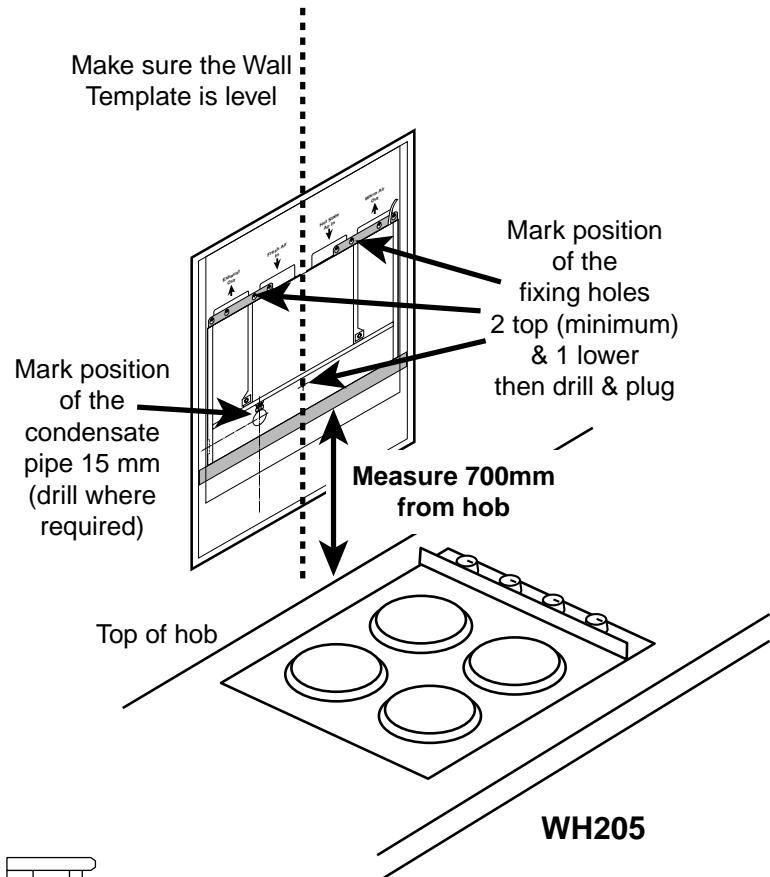

Place unit on its back & remove front cover

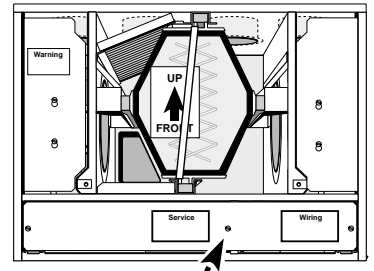

Remove bottom cover (3 screws)

Fig. 15

## 6.0 Installation

### 6.2 Assembly of the MVHR unit and the cooker hood - WH205 only.

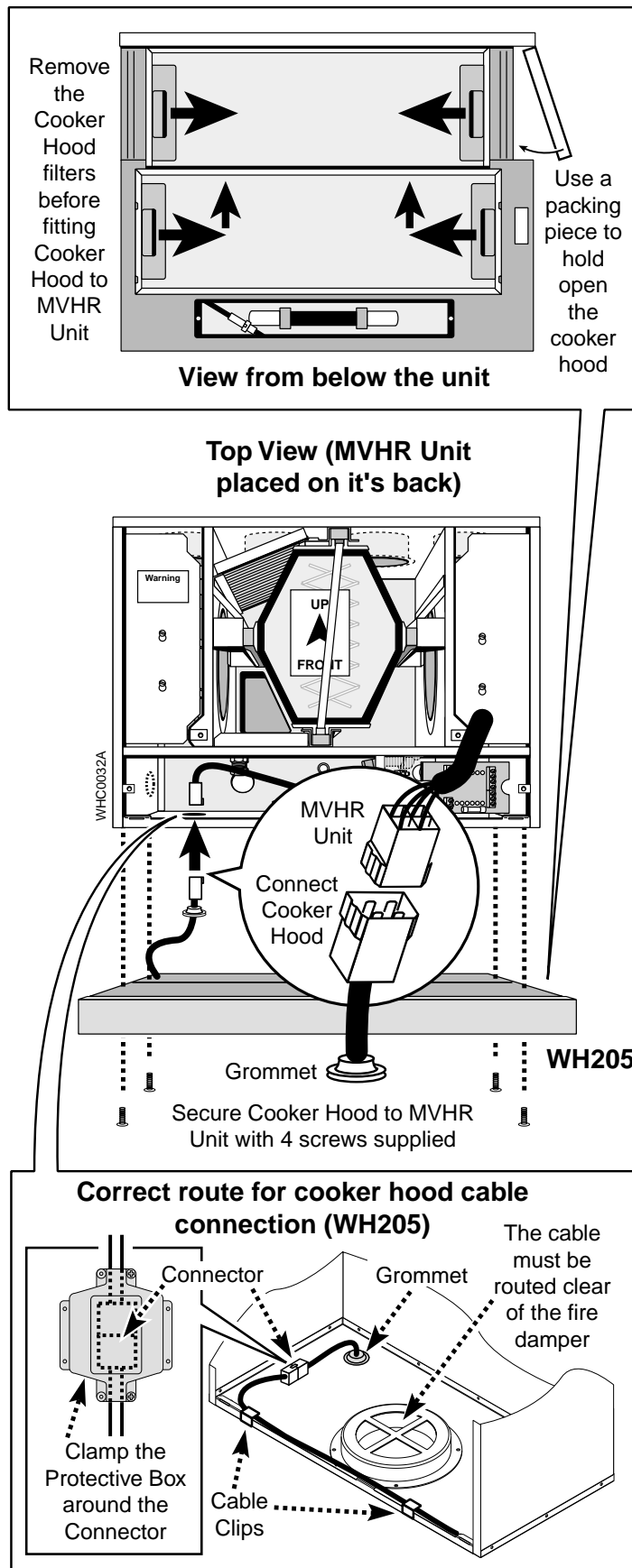

1. Unpack the cooker hood, locate the four screws and washers and the protective box for the cooker hood plug and socket.

2. Open out the telescopic hood and remove the two metal filters by releasing the grey plastic springs and sliding out.

3. Offer up the hood to the MVHR unit and carefully feed the cable and four pin cooker hood socket through the hole in the back right hand side of the MVHR unit.

4. Align the cooker hood and attach it to the MVHR unit using the four screws provided.

**Note: it will be necessary to support the telescopic hood when attaching it to the MVHR unit.**

5. Carefully route the cooker hood cable and socket into the MVHR unit and engage it with the plug ensuring the locating lugs align.

It is important that the cables are routed away from the cooker hood outlet and fire damper.

6. Locate the assembled plug and socket in the protective box taking care to route the cables as shown (Fig. 16). Clip the box together and secure using the screws provided. Locate the large cable grommet in the hole and ensure it is seated correctly.

### 6.3 Condensate outlet

1. If the condensate pipe is to exit the unit at the left hand side, stand the unit up on its base taking care not to damage the telescopic hood and filters.

2. Locate the semi-pierced hole and carefully remove the metal disc.

3. Swap over the grommet used on the rear exit hole and seal the rear hole with duct tape or similar.

**Note: The WH204 has an extra condensate outlet on the bottom panel.**

Fig. 16

## 6.0 Installation

### 6.4 Fitting the MVHR unit

1. Offer the combined unit to the wall and engage the keyhole slots over the screws previously fitted.

2. Make sure the unit is level and tighten the top screws before engaging the final screw.

### 6.5 Making the condensate connection

1. The condensate connector is suitable for 15 mm pipe.

2. The condensate pipe should incorporate a water trap to prevent foul air being drawn into the unit. The minimum height of the trap should be 75 mm.

**Note:** To ensure the condensate pipe is primed, slowly pour water into the condensate tray until it discharges into the drain.

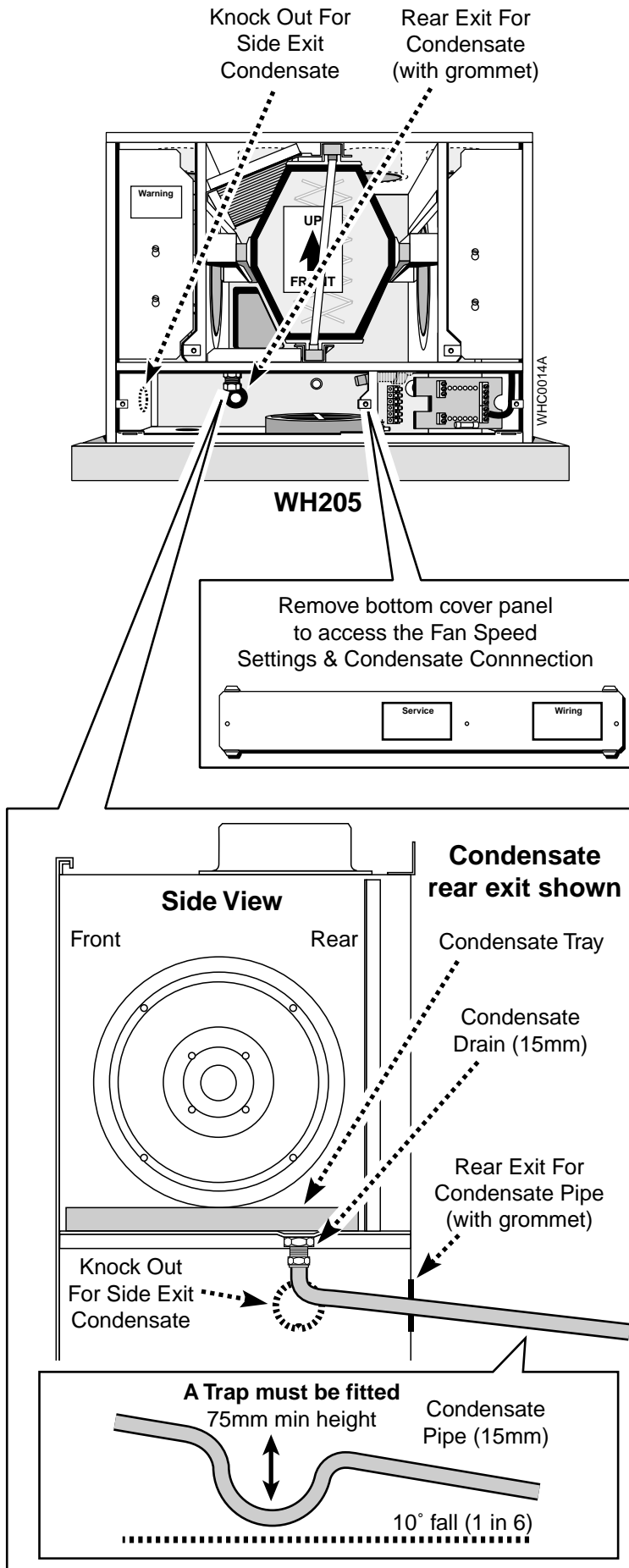

Fig. 17

## 6.0 Installation

### 6.6 Making the duct connections

1. The unit has four duct connections suitable for 100mm plastic pipe.

1. Exhaust outlet to outside
2. Air inlet from outside
3. Stale air inlet from dwelling
4. Fresh air outlet to dwelling

**Notes: It is essential that the duct system is connected as indicated.**

**It is important that the duct system does not interfere with the correct fitting of the outer door and does not prevent the correct operation of the unit.**

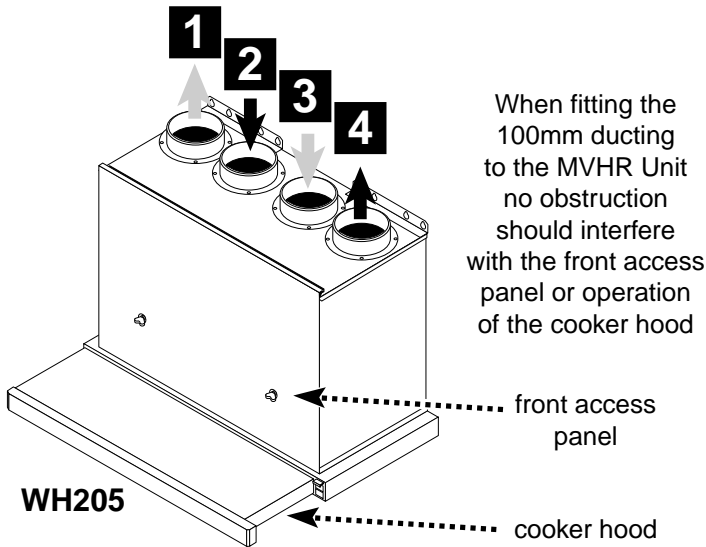

### 6.7 Controls

1. The WH204 requires external controls to enable normal/boost switching, see Page 20 - Wiring Diagrams.

2. The WH205 can have optional external controls fitted, see Pages 18 and 19 - Wiring Diagrams.

### 6.8 Making the electrical connection

**Warning: This appliance must be earthed**

1. The normal running speed of the fans is set at 120v.

2. The unit must be set to the appropriate voltage as determined by air flow required and duct system pressure loss (see Section 5.3).

To change the voltage setting for the fans, unscrew and remove the white wire from the 120v connection on the controller.

3. Carefully insert the wire into the desired connection (80, 100, 120, 140 or 160) and secure the wire.

4. Fit the bottom cover panel.

5. Connect the flying lead to the mains supply - see Section 5.6.

6. Check the electrical installation for; Earth continuity, short circuits, resistance to earth and correct polarity.

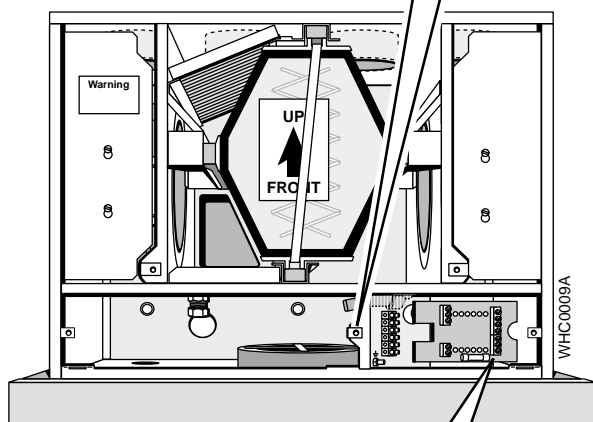
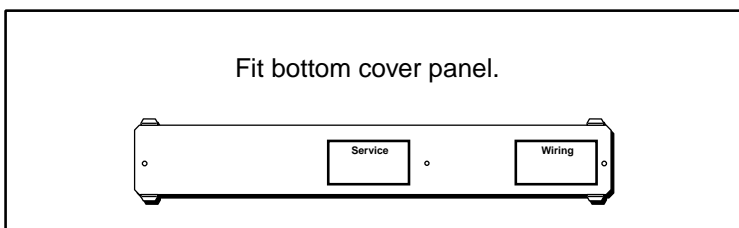
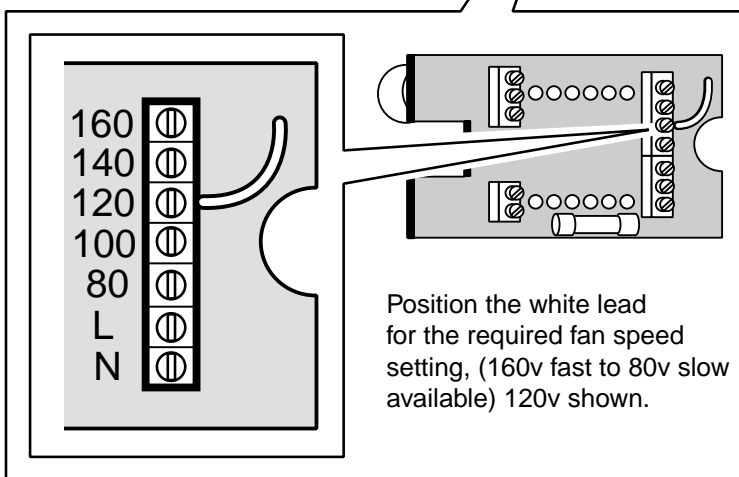

Fig. 18



# 7.0 Wiring Diagrams

## WH205 MVHR Unit Wiring

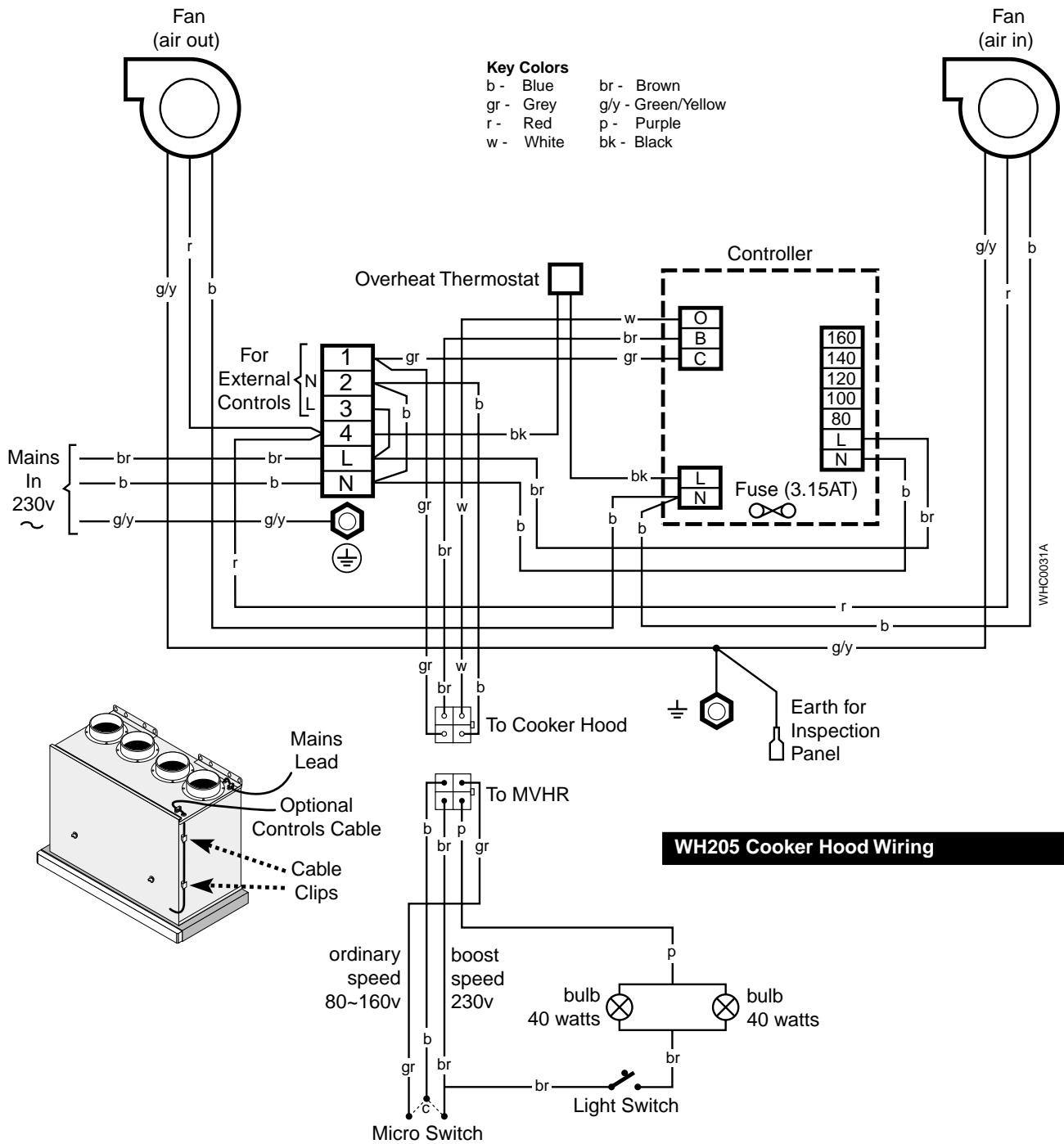
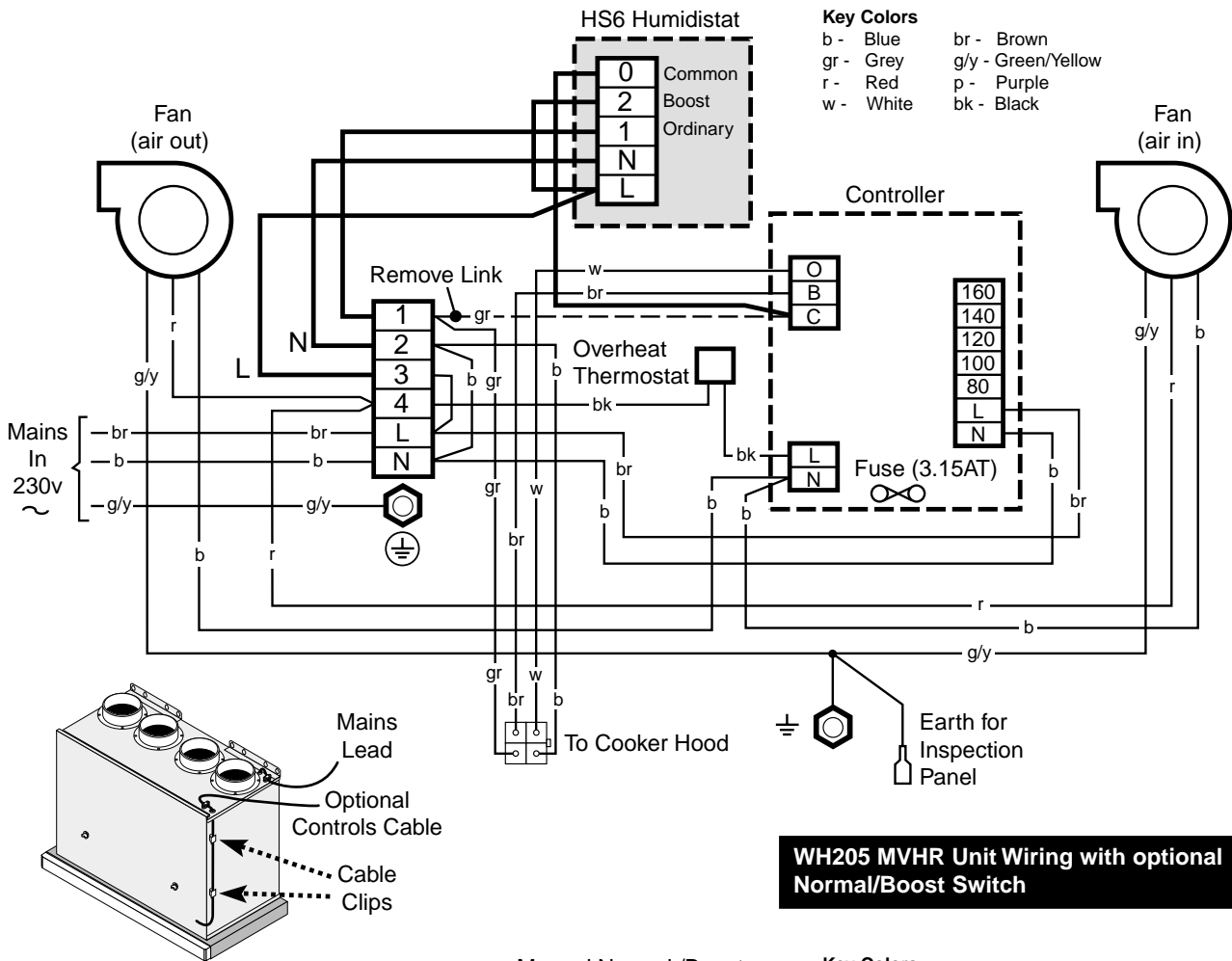

Fig. 19

## 7.0 Wiring Diagrams

### WH205 MVHR Unit Wiring with optional Humidstat HS6



### WH205 MVHR Unit Wiring with optional Normal/Boost Switch

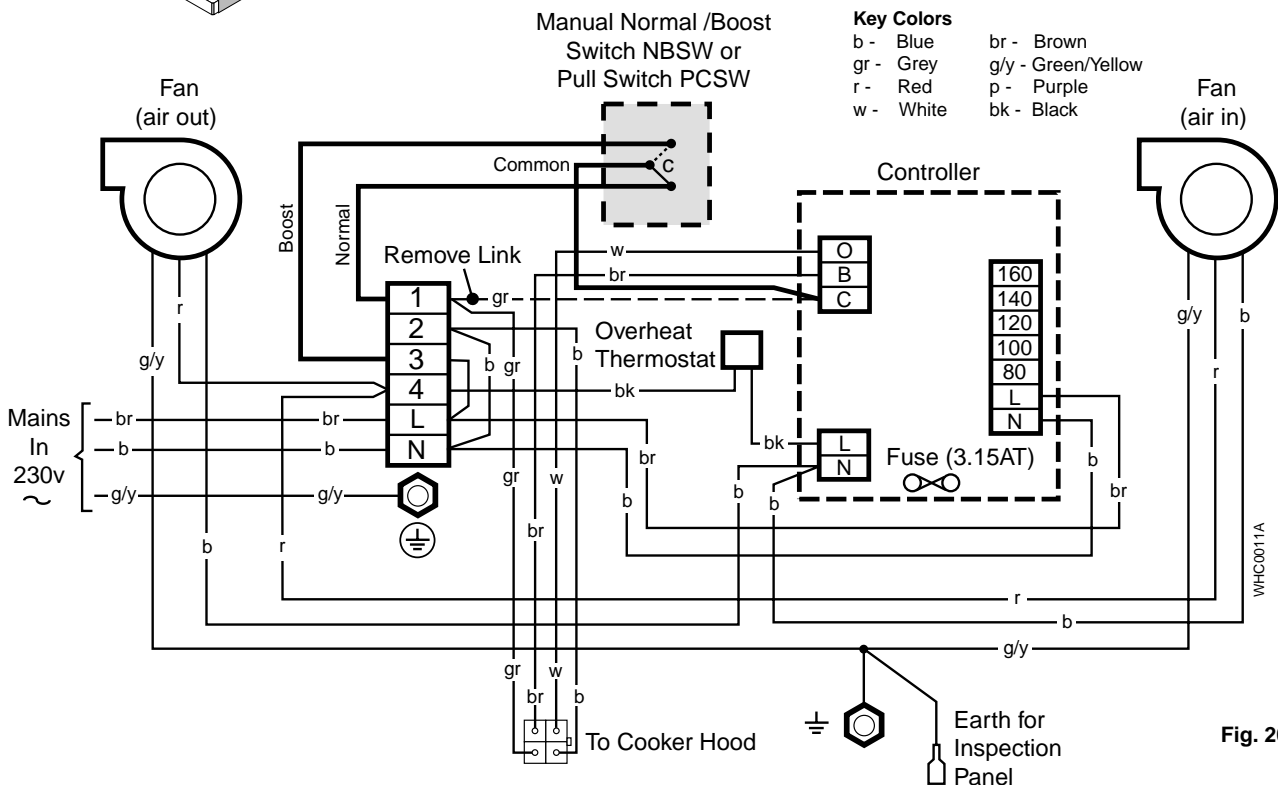

Fig. 20

# 7.0 Wiring Diagrams

## WH204 MVHR Unit Wiring

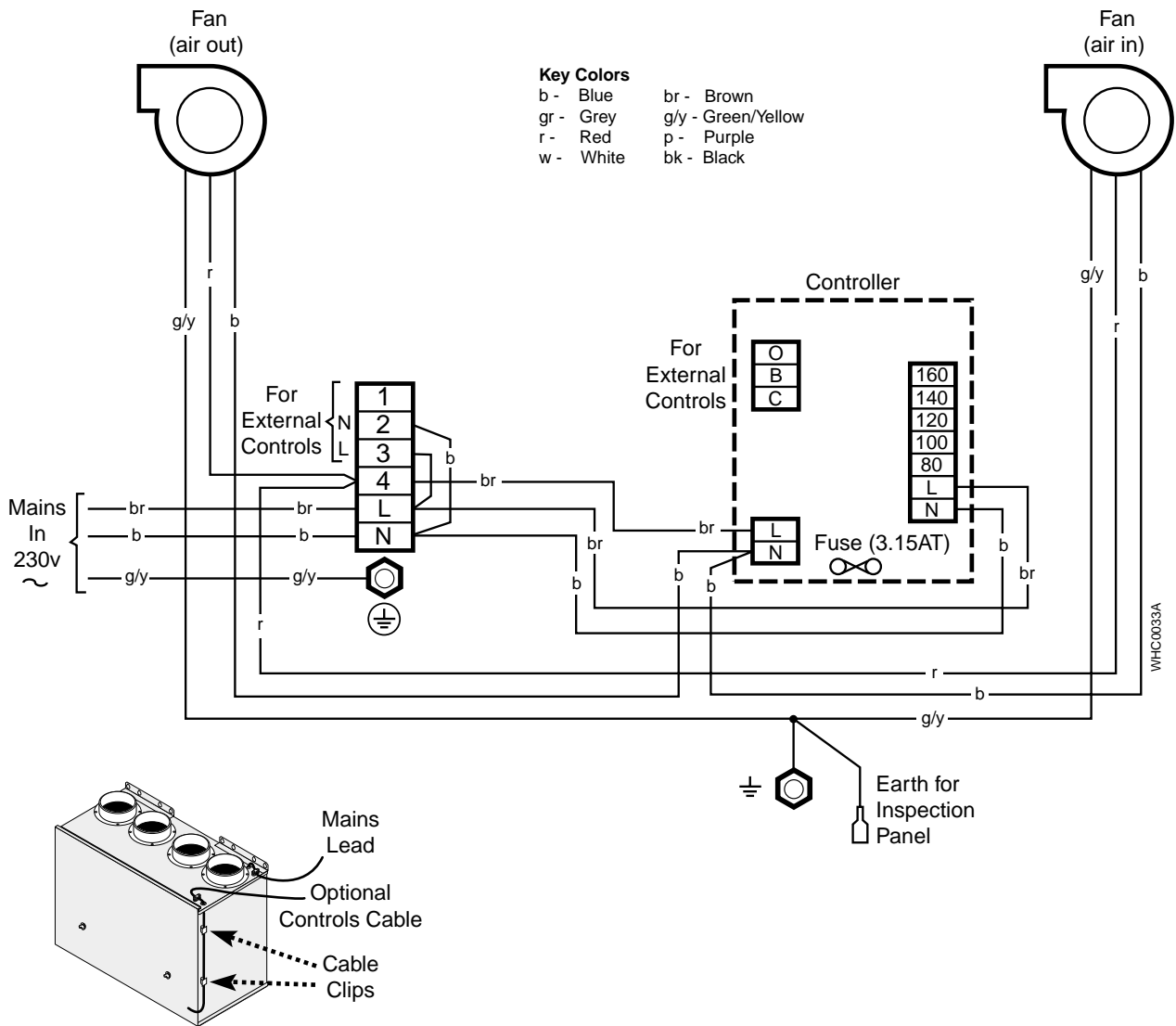
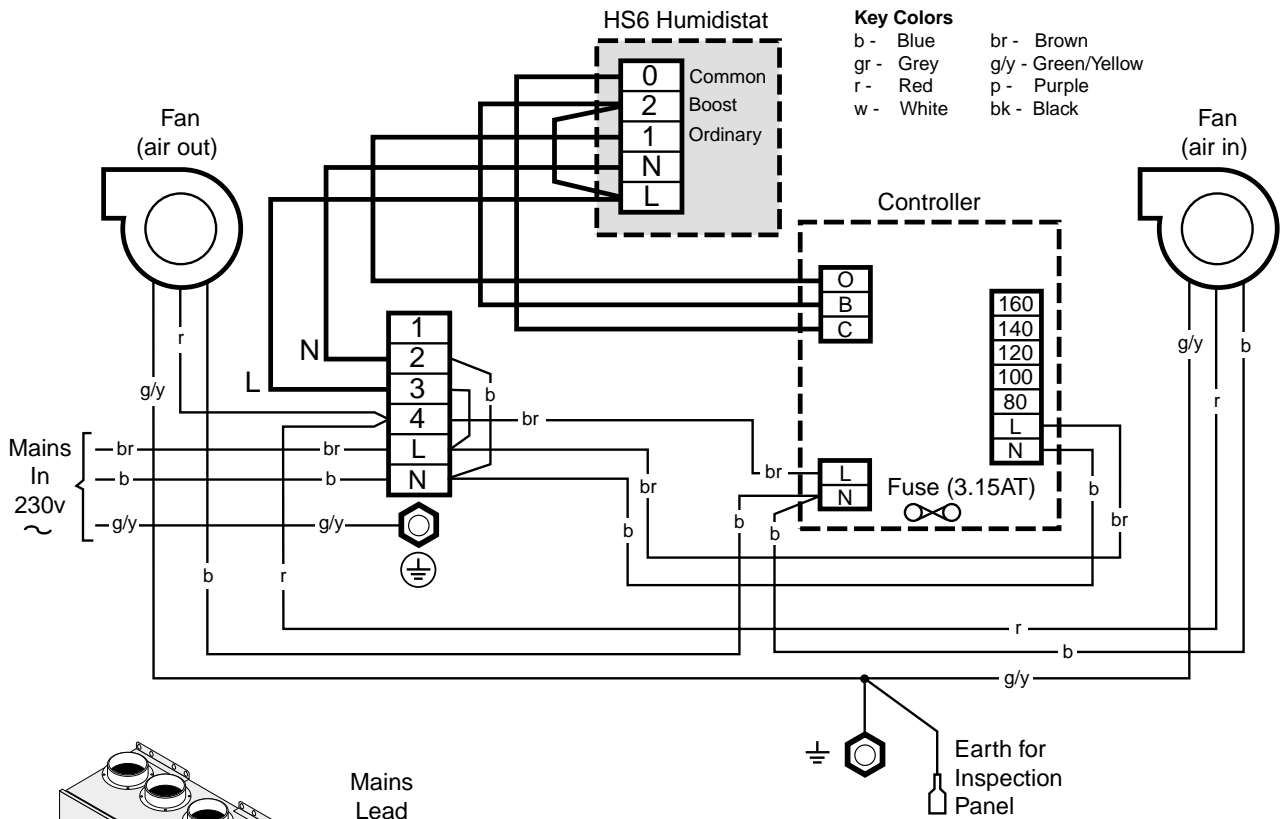

Fig. 21

## 7.0 Wiring Diagrams

### WH204 MVHR Unit Wiring with optional Humidstat HS6



### WH204 MVHR Unit Wiring with optional Manual/Boost Switch

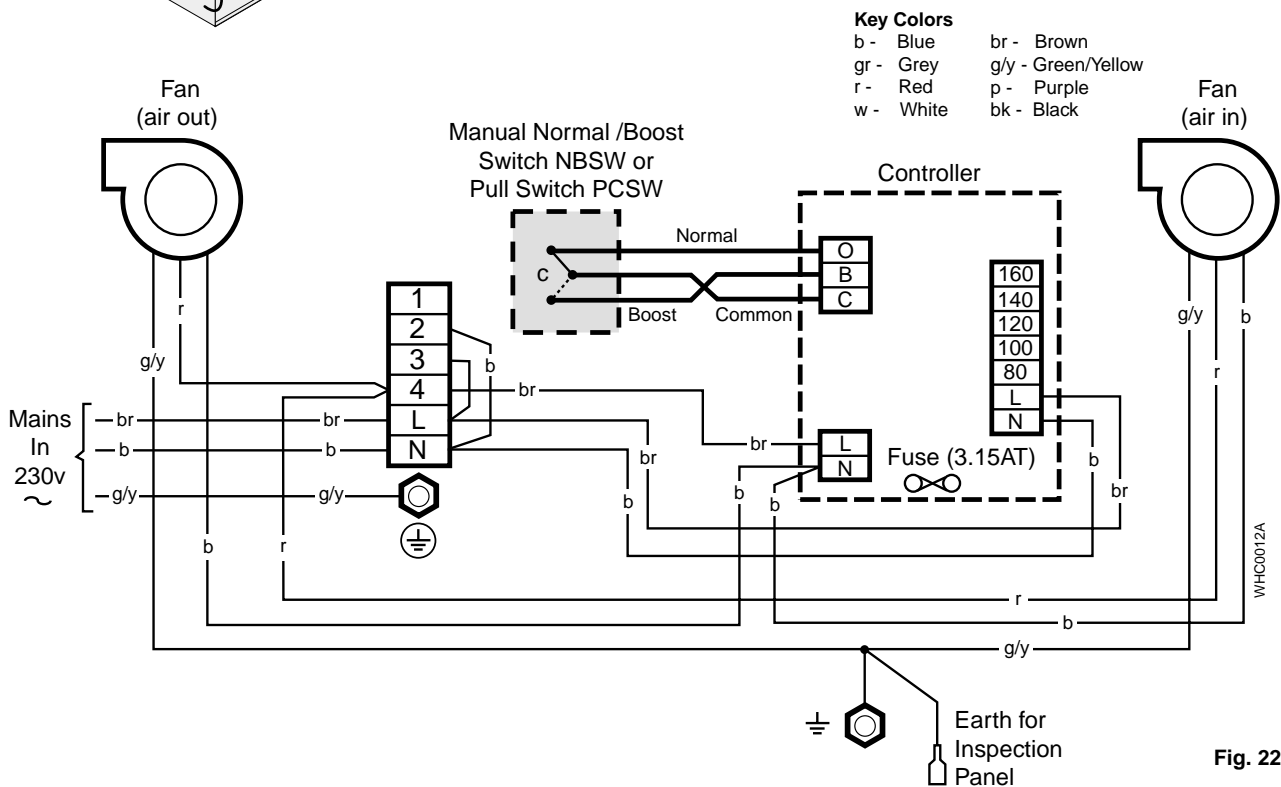

Fig. 22

## 8.0 Commissioning

---

### 8.1 Prepare for commissioning - WH205

1. Refit the front door panel by hooking it over the top lip of the appliance and swinging down. Tighten the two case screws.
  2. Ensure the telescopic hood is retracted.
  3. Turn on the electrical supply. The unit will now start running at the normal ventilation speed.
  4. Pull the telescopic hood forward. The unit will now switch to boost speed.
  5. Check the operation of the cooker hood lights.
- 

### 8.1a Prepare for commissioning - WH204

1. Refit the front door panel by hooking it over the top lip of the appliance and swinging down. Tighten the two case screws.
2. Check the external controls are set to normal running.
3. Turn on the electrical supply. The unit will now start running at the normal ventilation speed.
4. Set the external control to boost. The unit will now switch to boost speed.

## 8.0 Commissioning

### 8.2 Balancing the system

**Note:** It is important that a suitable anemometer is used to balance the system therefore giving the required ventilation rates to each room.

1. Set the appliance running on normal speed.
2. Make a preliminary adjustment of all the duct inlet and outlet louvres.

**Note:** The supply air terminal is directional and incorporates a deflector plate. Ensure that the deflector plate is correctly positioned so that the active part of the terminal is discharging to the room.

3. Check the flow rate and adjust if necessary the extract valve furthest from the appliance.
4. Check the flow rates and adjust if necessary the remaining extract valves.
5. Repeat the flow checks and adjust until the extract system is balanced.
6. Check the flow rate and adjust if necessary the inlet valve furthest from the appliance.
7. Check the flow rate and adjust if necessary the remaining inlet valves.
8. Repeat the checks and adjust until the system is correctly balanced.

**Note:** If the flow rates have been achieved with all the louvres nearly closed, it may be possible to reduce the fan speed and re-adjust the louvre settings.

### 8.3 Instruct the user

Instruct the user in the operation of the appliance. Hand over these instructions, giving advice on the necessity for regular servicing of the filters and heat exchanger.

**Note:** It is important that any door or cupboard front covering the MVHR unit is easily removable by the user as access for regular cleaning of the air filter and heat exchanger is required.

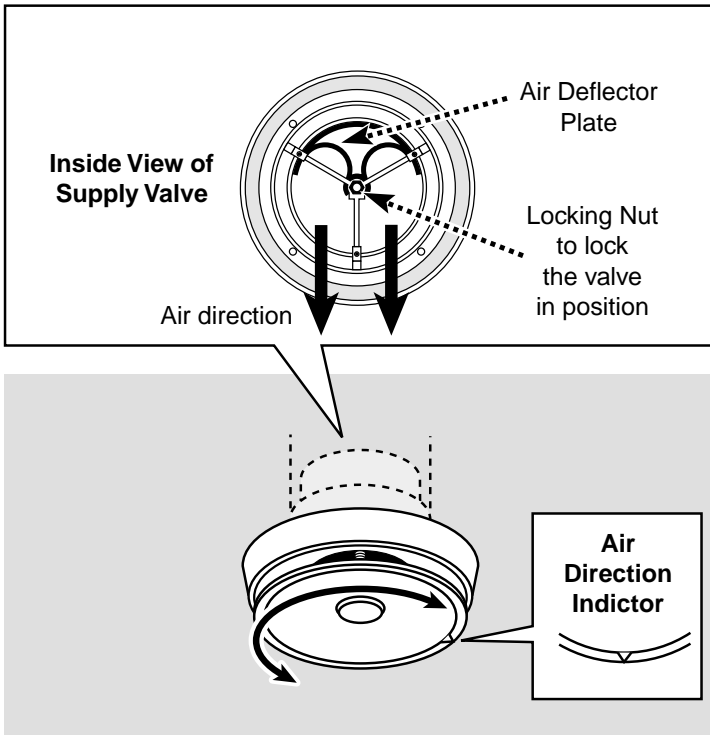

#### SV100

Adjust Ceiling Supply Valve for Living Room etc

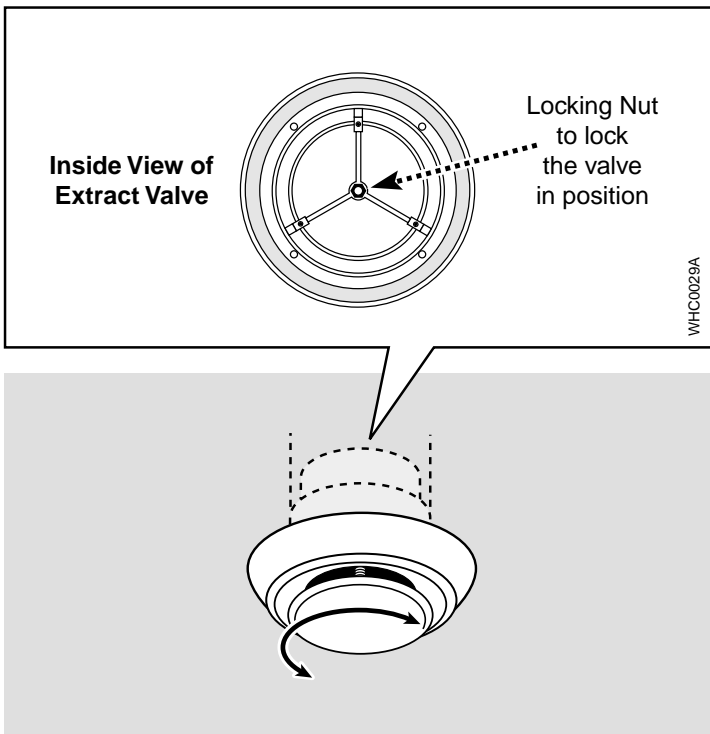

#### EV100

Adjust Ceiling Extract Valve for Bathroom etc

Fig. 23

## 9.0 Maintenance

**Important: Before servicing ensure that the appliance is isolated from the electrical supply. After isolating from the electrical supply, allow one minute for the fans to stop rotating before servicing the appliance.**

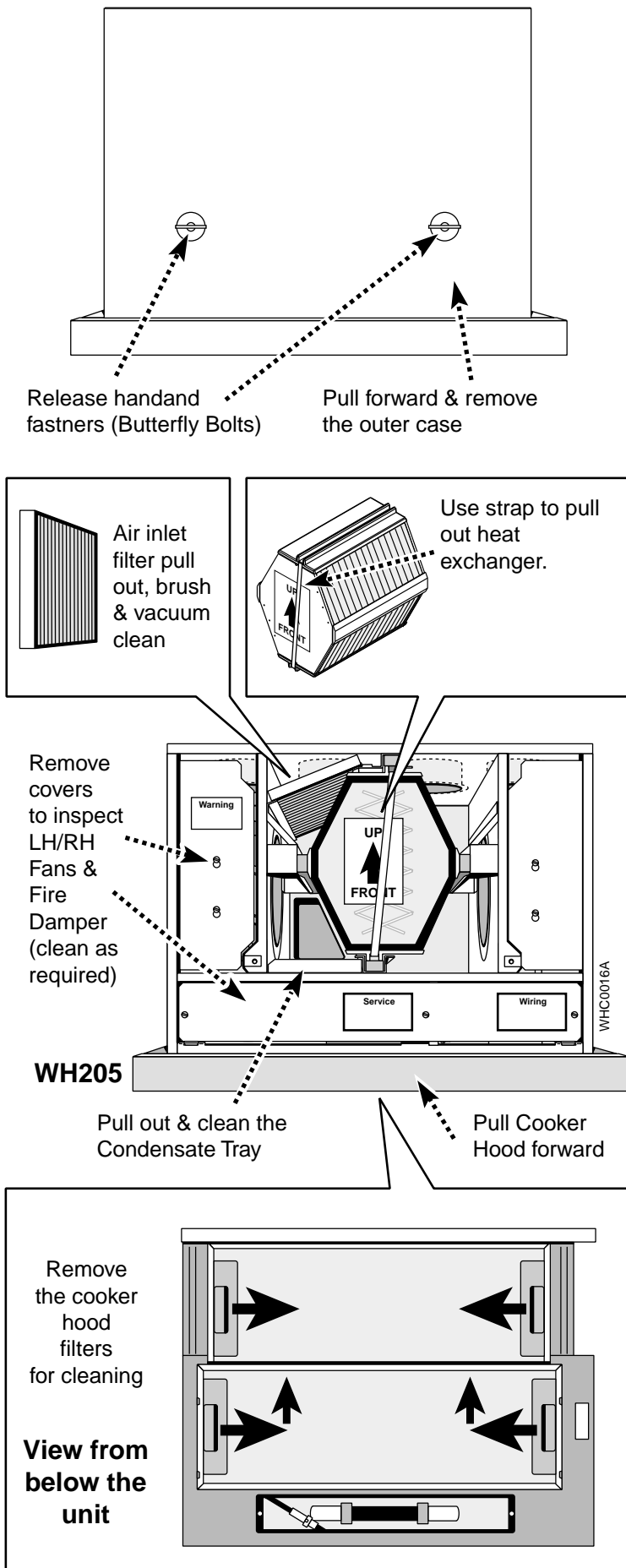

Fig. 24

1. WH205 only -Extend the telescopic hood and remove the two metal filters. The cooker hood filters can be washed in a dishwasher; alternatively a hot hand wash will suffice. Check and clean the filters if necessary. Dry the filters thoroughly before re-fitting.

2. Lift off the front door panel by releasing the two hand screws and lifting upwards.

3. Identify the air inlet filter and remove by pulling forwards.

Taking note of the offset sliders, carefully remove the heat exchanger by gently pulling forwards.

4. Remove the bottom electrical cover by releasing the 3 screws, pulling the panel forwards and disconnecting the earth lead to the panel.

5. Loosen the two screws on each side plate and lift to remove.

6. WH205 only - Check the cooker hood inlet for debris and fat deposits. Clean as required. Check the fire damper is in satisfactory condition and unaffected by debris and fat deposits. Replace if necessary.

7. Check both fans, fan compartments and exhaust duct outlets for deposits. Clean as necessary.

8. Remove the condensate tray by pulling forwards. Check and clean if necessary.

9. Check the condition of the four heat exchanger sealing strips and front door seal. Replace all seals as necessary (Fig. 24).

10. Carefully wash the heat exchanger in warm soapy water taking care not to loosen the heat exchanger fins. Thoroughly dry the heat exchanger before re-fitting.

**Note: Ensure the heat exchanger is located correctly in the offset sliders.**

11. Carefully vacuum the air inlet filter. Replace if necessary.

12. Re-assemble in reverse order and re-fit the outer door ensuring the door makes a good seal.

## 9.0 Maintenance

---

13. Turn on the electrical supply to the appliance. With the hood closed the appliance will run on normal setting. Extend the hood and the appliance will switch to boost setting. With the appliance on boost check the operation of the cooker lights

14. Check the condition of the ductwork system, the soundness of all joints and repair if necessary

## 10.0 Changing Components

**IMPORTANT: ISOLATE FROM THE ELECTRICAL SUPPLY BEFORE STARTING ANY WORK ON THE APPLIANCE.**

The fans continue to rotate for one minute after isolating from the electrical supply

### 10.1 Controller

1. WH205 Only - Fully extend the telescopic cooker hood and remove the two metal filters.
2. Remove the outer door by releasing the two screws and lifting the door up and forwards.
3. Remove the bottom electrical cover by releasing the 3 screws, pulling the panel forwards and disconnecting the earth lead to the panel. Make a note of the voltage setting for the fans and of the wiring arrangement for the controller.
4. Release all the wires connected to the controller.
5. Remove R.H. fan cover panel and remove the R.H. fan (see Section 10.3). Unscrew the two screws securing the controller mounting bracket to the bulkhead and remove the bracket and controller unit. Separate the bracket from controller by removing the four screws.
6. Re-assemble with the new controller in reverse order. **Check the electrical installation for; Earth continuity, short circuits, resistance to earth and correct polarity.**

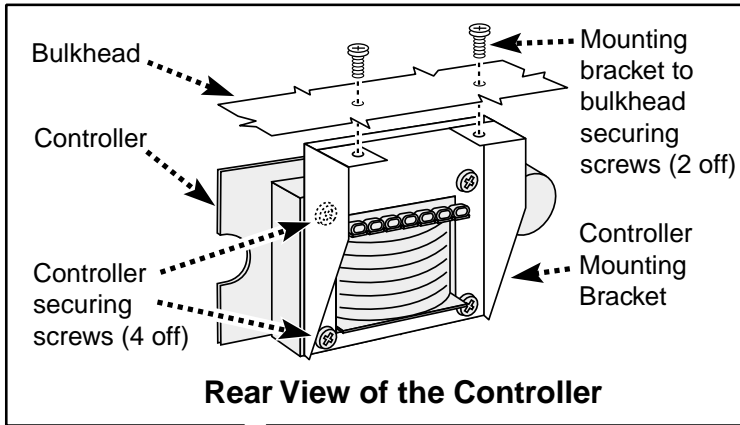

**Rear View of the Controller**

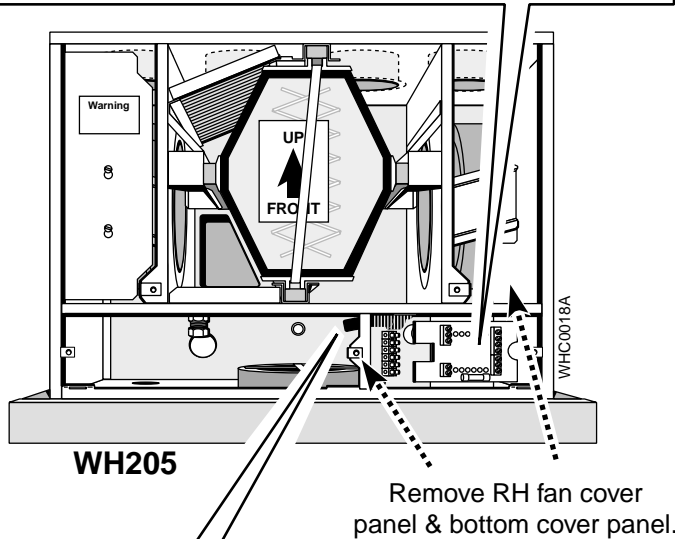
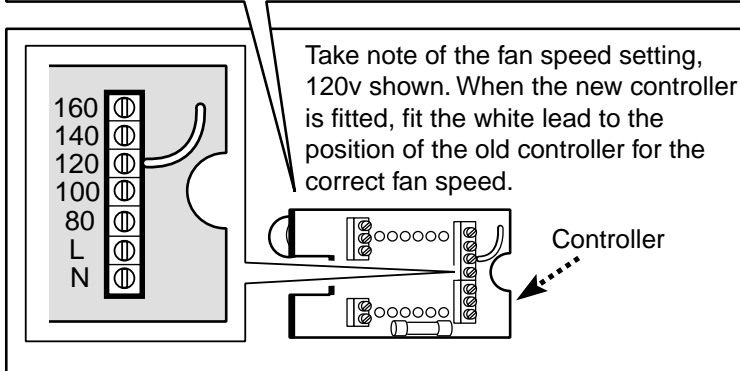

**WH205**

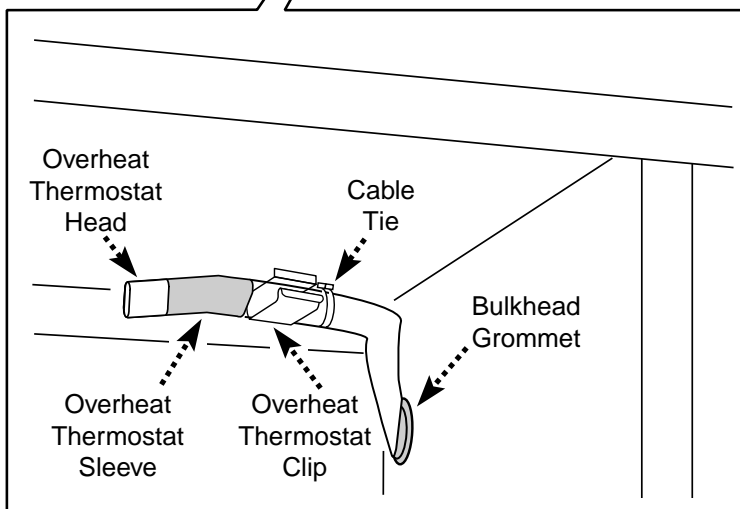

**Fig. 25**

### 10.2 Overheat thermostat - WH205 Only

1. Lift off the front door panel by releasing the two hand screws and lifting upwards.
2. Remove the bottom electrical cover by releasing the 3 screws, pulling the panel forwards and disconnecting the earth lead to the panel. Identify the connections for the overheat thermostat. Make a note of the routing for the overheat thermostat cable.
3. Release the overheat thermostat connections.
4. Release the sensor head by springing open the clip and pulling out the sensor head.
5. Remove the overheat thermostat taking care not to dislodge the bulkhead grommet.
6. Carefully locate the new sensor and position the lead as shown in Fig. 26. Re-assemble with the new overheat thermostat in reverse order. **Check the electrical installation for; Earth continuity, short circuits, resistance to earth and correct polarity.**

## 10.0 Changing Components

### 10.3 Extract fan and Inlet fan

1. Lift off the front door panel by releasing the two hand screws and lifting up wards.
2. Loosen the two screws on the side plate and lift to remove.
3. Release the clip on the plastic plug and disconnect the plug.
4. Slacken the two rear fan bracket screws.
5. Remove the two front fan bracket screws and remove the fan assembly.  
Note the position of the fan bracket relative to the fan.
6. Remove the bracket and re-fit to the new fan.
7. Re-assemble with the new fan in reverse order ensuring the cable does not foul the fan motor. **Check the electrical installation for; Earth continuity, short circuits, resistance to earth and correct polarity.**

### 10.4 Fan capacitor

1. Lift off the front door panel by releasing the two hand screws and lifting up wards.
2. Loosen the two screws on the side plate and lift to remove.
3. Release the clip on the plastic plug and disconnect the plug.
4. Slacken the two rear fan bracket screws.
5. Remove the two front fan bracket screws and remove the fan assembly.
6. Disconnect the two 2.5 mm spade terminals from the capacitor.
7. Cut the two cable ties and remove the capacitor.
8. Re-assemble in reverse order with the new capacitor and use the new cable ties provided. Ensure the cable does not foul the fan motor. **Check the electrical installation for; Earth continuity, short circuits, resistance to earth and correct polarity.**

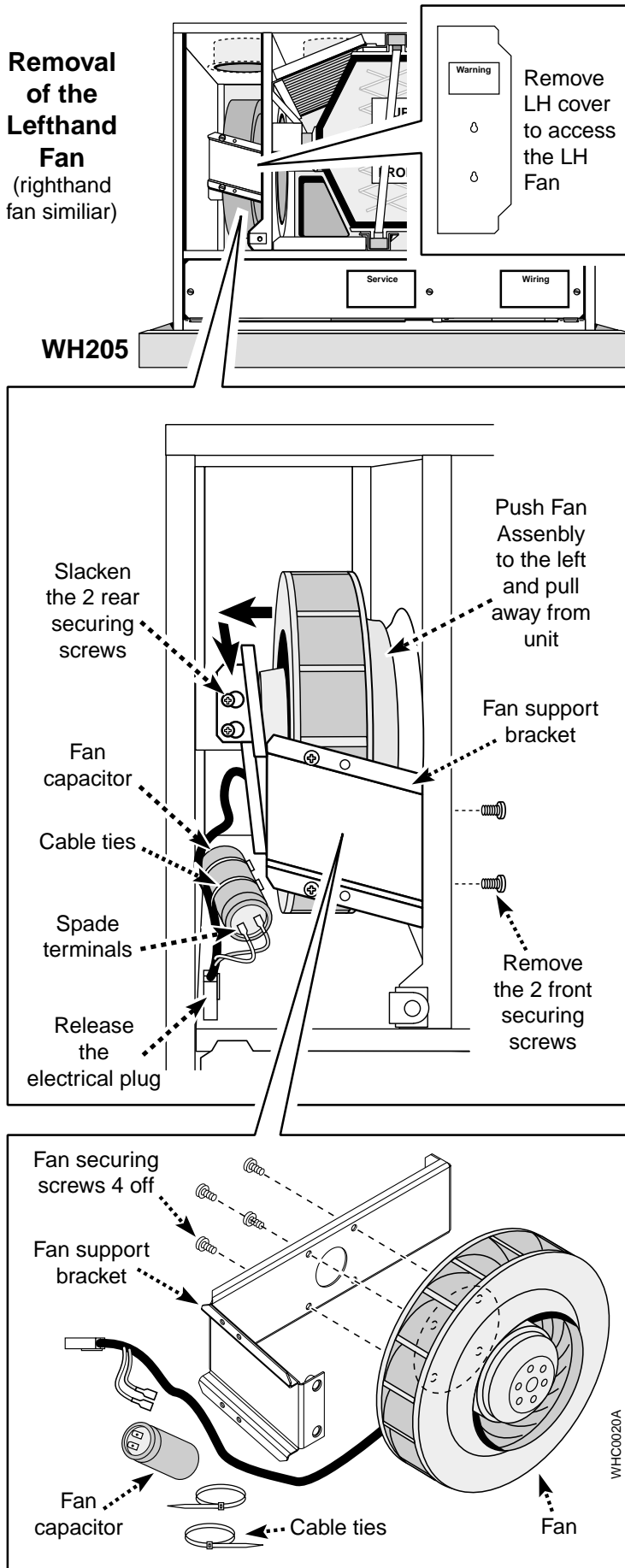
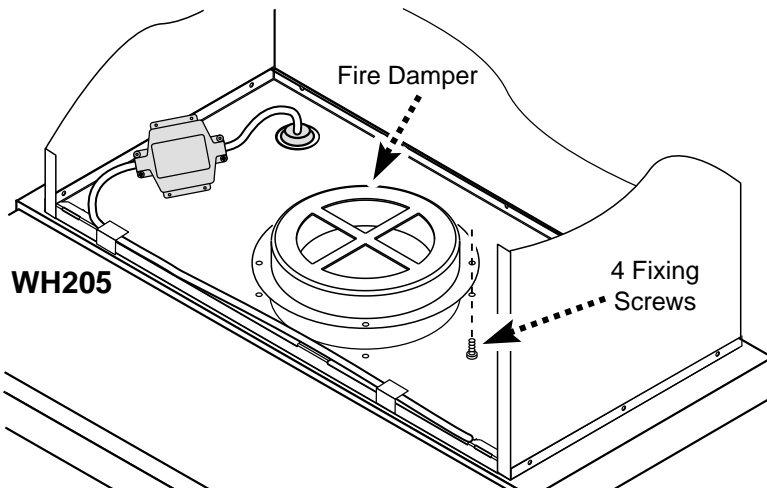

Fig. 26

## 10.0 Changing Components

### 10.5 Fire damper - WH205 Only

1. Fully extend the telescopic cooker hood.
2. Remove the two metal filters.
3. Remove the outer door by releasing the two screws and lifting the door up and forwards.
4. Remove the bottom electrical cover by releasing the 3 screws, pulling the panel forwards and disconnecting the earth lead to the panel.
5. Remove the four screws that secure the fire damper and lift it away from the unit.



### 10.6 Heat exchanger

1. Lift off the front door panel by releasing the two hand screws and lifting up wards.
2. Gently ease the heat exchanger forwards and remove.
3. Re-assemble in reverse order taking care not to damage the heat exchanger seals.

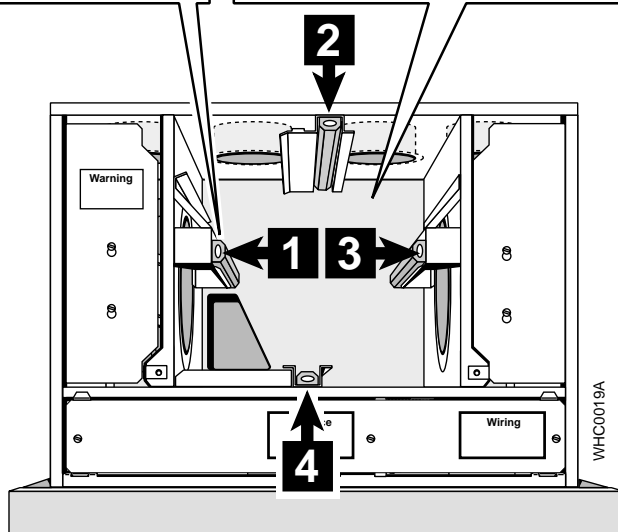
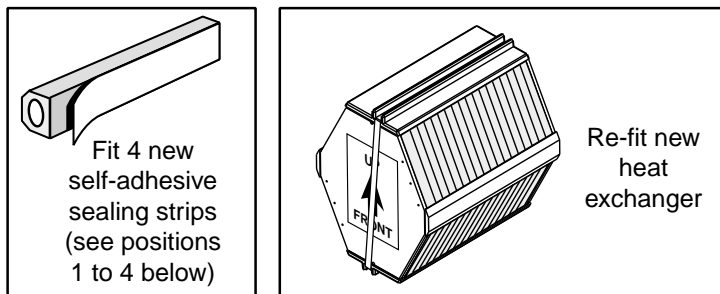

### 10.7 Heat exchanger seals

1. Lift off the front door panel by releasing the two hand screws and lifting up wards.
2. Gently ease the heat exchanger forwards and remove.
3. Remove the four heat exchanger seals taking care to remove all the old adhesive backing.
4. Fit the new seals ensuring they make good contact with the location channel.
5. Re-assemble in reverse order taking care not to damage the heat exchanger seals.

### 10.8 Cooker hood seals

1. Fully extend the cooker hood.
2. Remove the metal filters.
3. Pull away the old cooker hood seal and remove any remaining glue. Use a small amount of solvent if necessary.
4. Peel back the adhesive strip and carefully fit the new seal as shown in Fig. 28.
5. Re-assemble in reverse order.

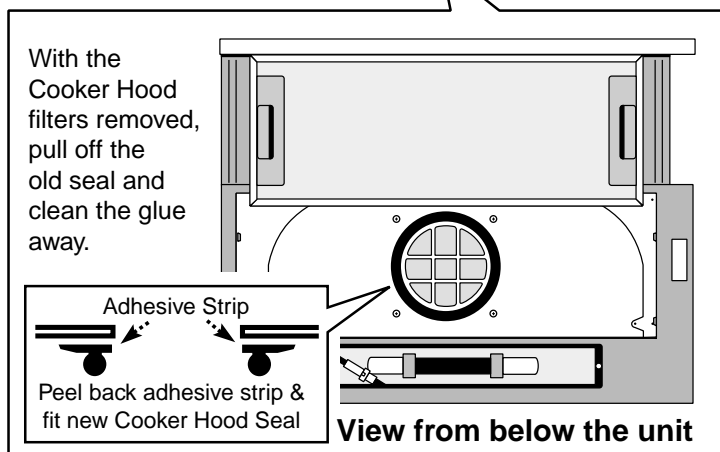

Fig. 27

This page is intentionally blank

# 11.0 Fault Finding

## WH205 - Main Unit Fault Finding Chart

Before starting FAULT FINDING carry out preliminary electrical systems checks i.e. Earth Continuity, Polarity, Short Circuit and Resistance to Earth.

Ensure all external controls are operating and are set to normal running. Ensure that a mains electrical supply is available to the unit.

Refer to diagrams below to identify terminals on components (e.g. A1, D3 etc).

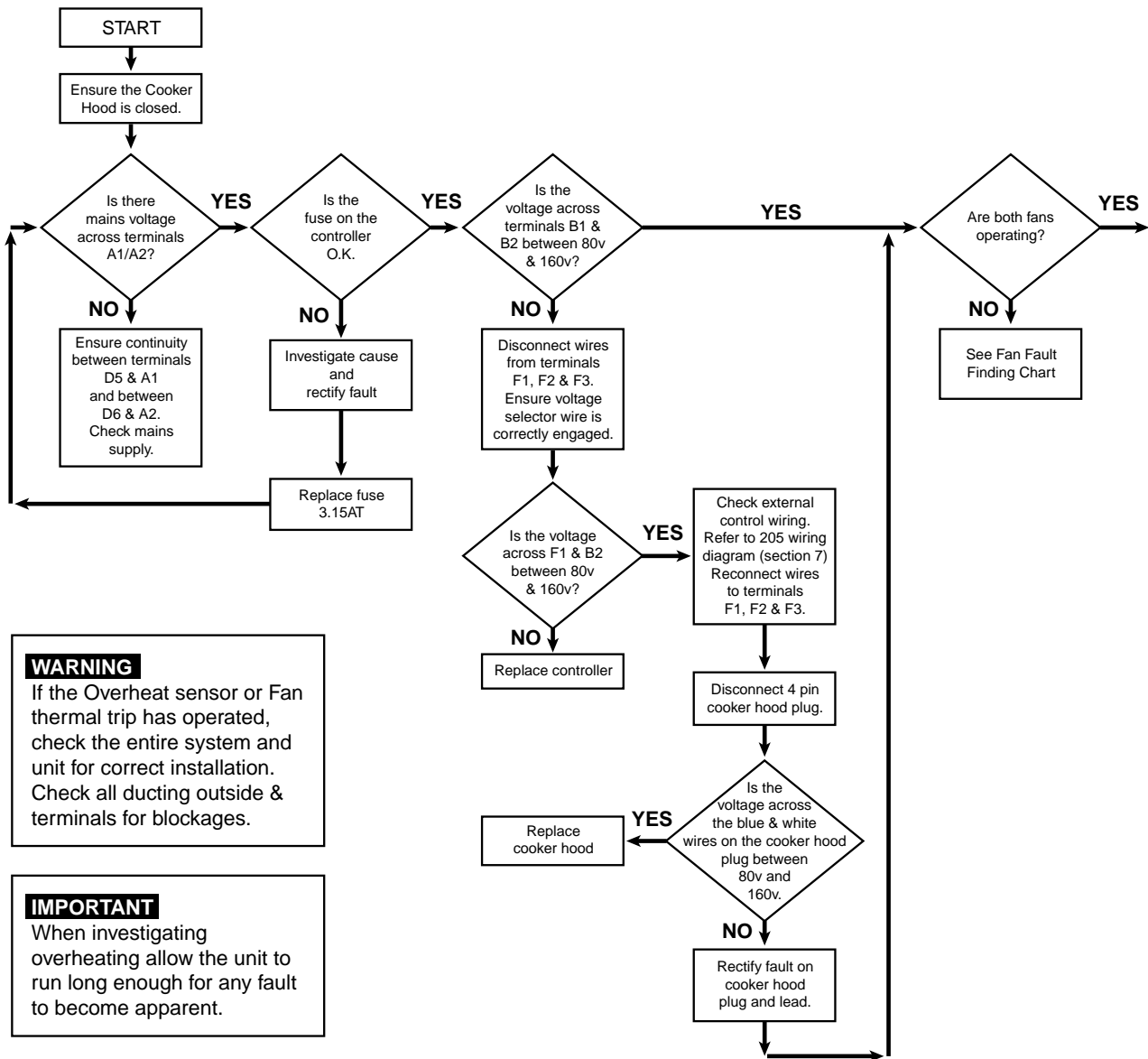

**WARNING**  
If the Overheat sensor or Fan thermal trip has operated, check the entire system and unit for correct installation. Check all ducting outside & terminals for blockages.

**IMPORTANT**  
When investigating overheating allow the unit to run long enough for any fault to become apparent.

**Note 1**  
Electricity supply must be isolated and Fan Motor temperature must be less than 100° to allow thermal trip to reset.

**Note 2**  
Electricity supply must be isolated and Overheat temperature must be less than 80° to allow Overheat Thermostat to reset.

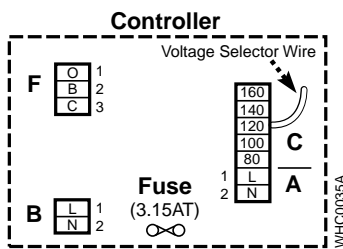
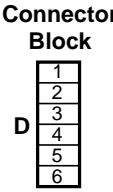
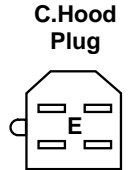
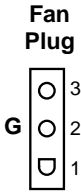

# 11.0 Fault Finding

## WH205 - Main Unit Fault Finding Chart

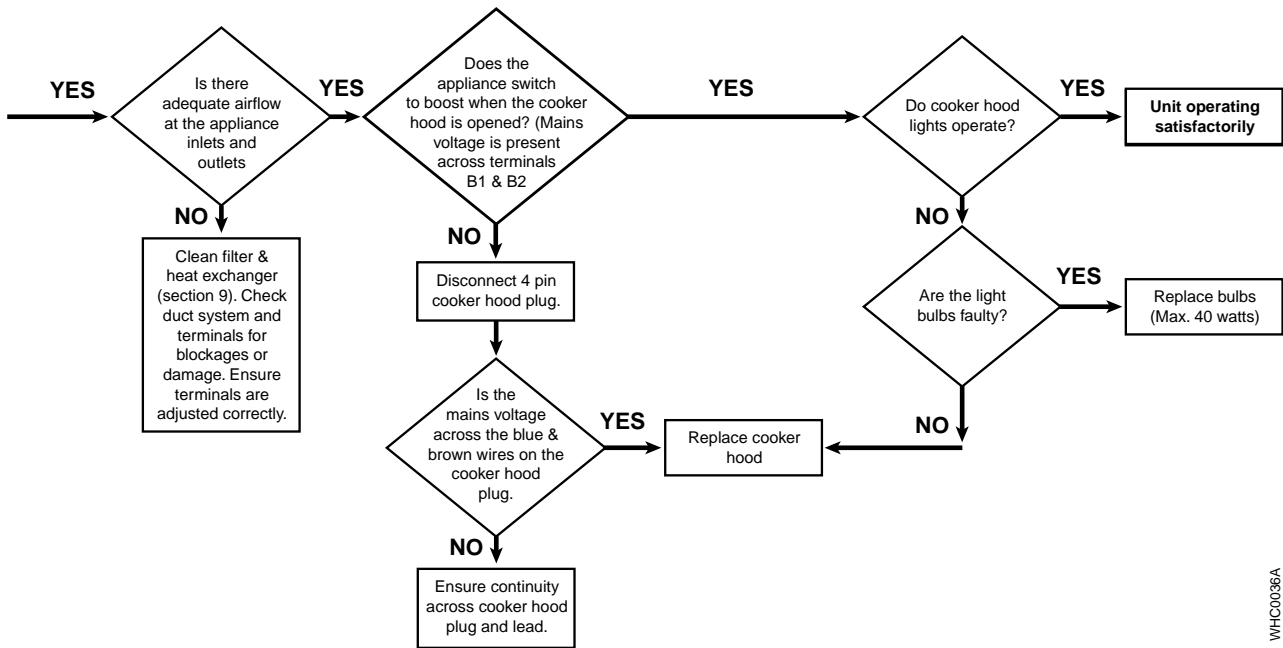

WHC0036A

# 11.0 Fault Finding

## WH204 - Main Unit Fault Finding Chart

Before starting FAULT FINDING carry out preliminary electrical systems checks i.e. Earth Continuity, Polarity, Short Circuit and Resistance to Earth.

Ensure all external controls are operating and are set to normal running. Ensure that a mains electrical supply is available to the unit.

Refer to diagrams below to identify terminals on components (e.g. A1, D3 etc).

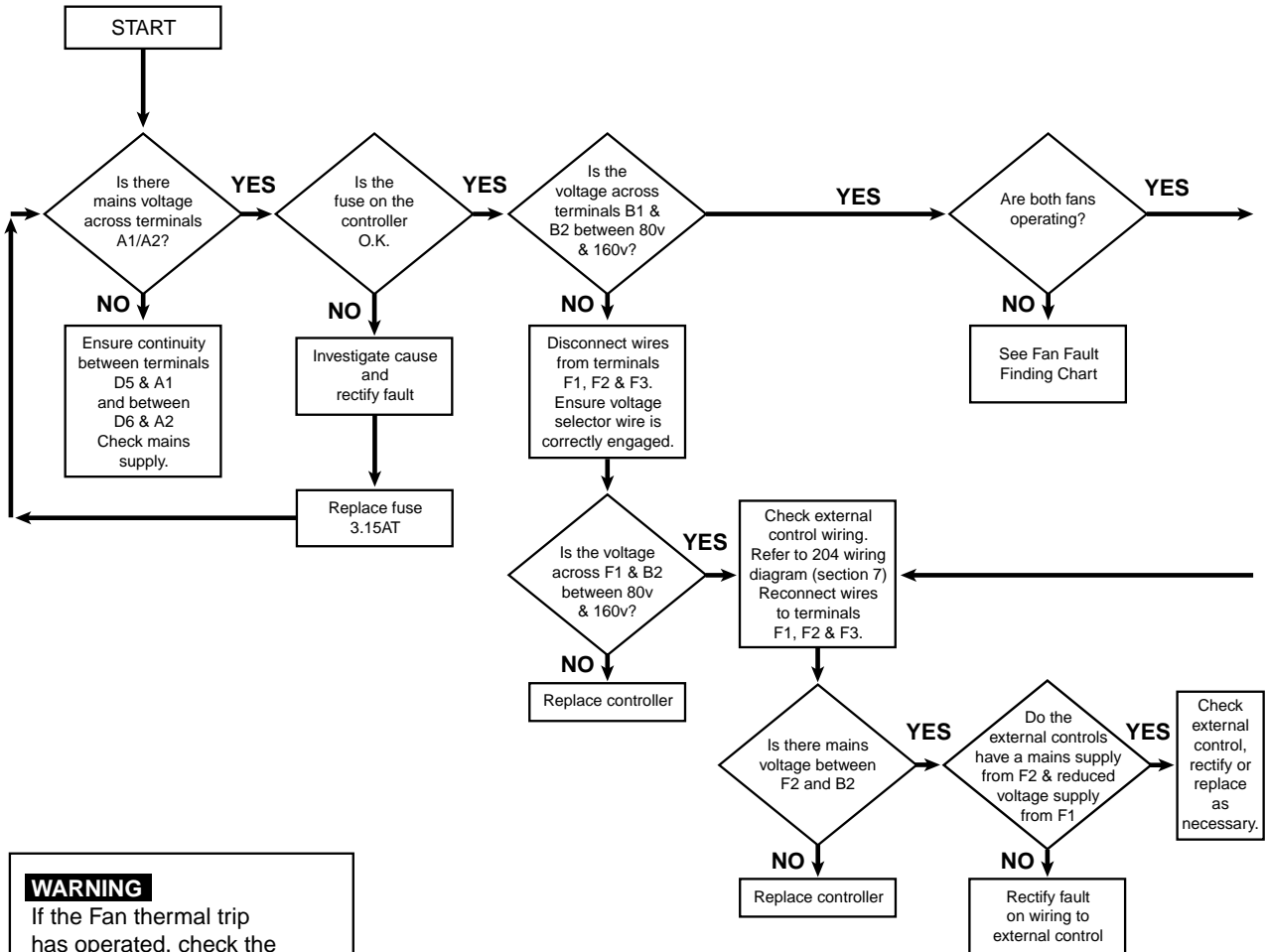

**WARNING**  
If the Fan thermal trip has operated, check the entire system and unit for correct installation. Check all ducting outside & terminals for blockages.

**IMPORTANT**  
When investigating overheating allow the unit to run long enough for any fault to become apparent.

**Note 1**  
Electricity supply must be isolated and Fan Motor temperature must be less than 100° to allow thermal trip to reset.

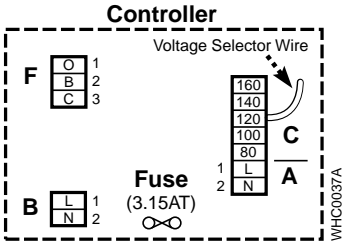
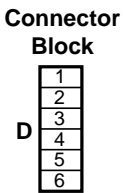
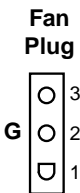

# 11.0 Fault Finding

## WH204 - Main Unit Fault Finding Chart

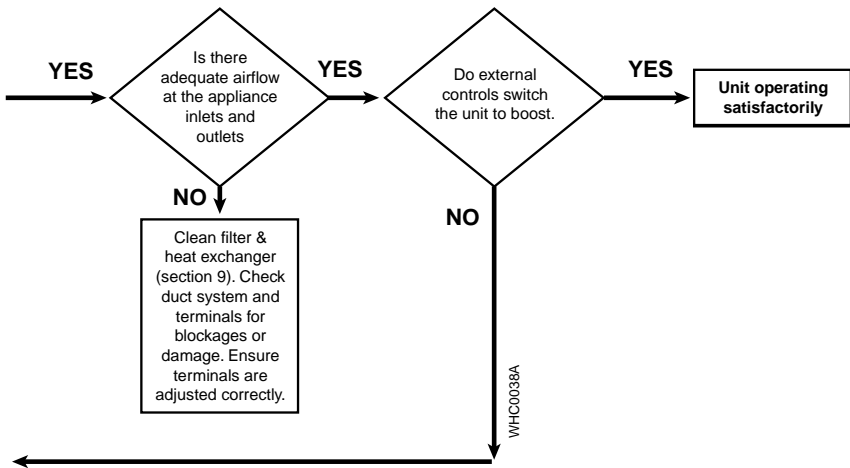

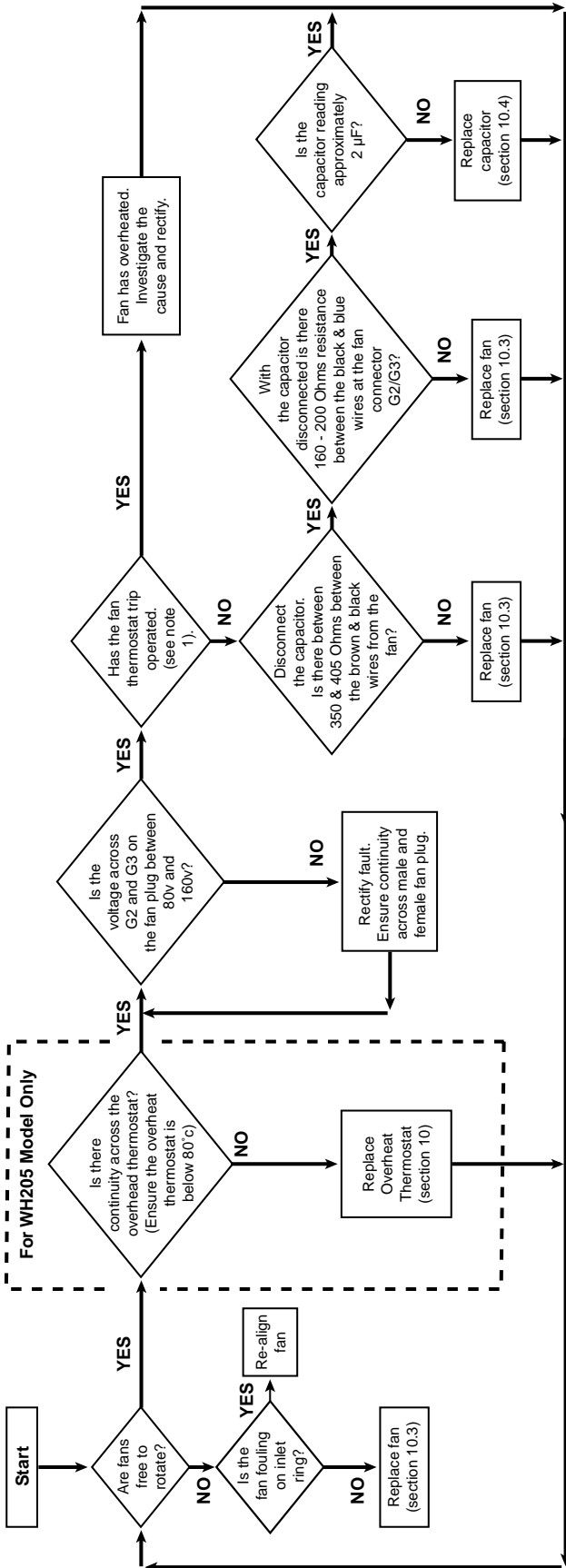

# 11.0 Fault Finding

## Fan Circuit Fault Finding Chart

**WARNING**  
If the Overheat sensor or Fan thermal trip has operated, check the entire system and unit for correct installation. Check all ducting outside & terminals for blockages.

**IMPORTANT**  
When investigating overheating allow the unit to run long enough for any fault to become apparent.

**Note 1**  
Electricity supply must be isolated and Fan Motor temperature must be less than 100° to allow thermal trip to reset.

**Note 2**  
Electricity supply must be isolated and Overheat temperature must be less than 80° to allow Overheat Thermostat to reset.

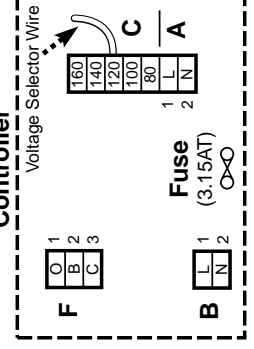
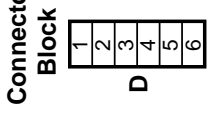
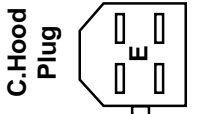
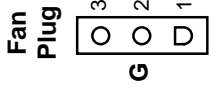

WHC0039A

## 12.0 Short Parts List

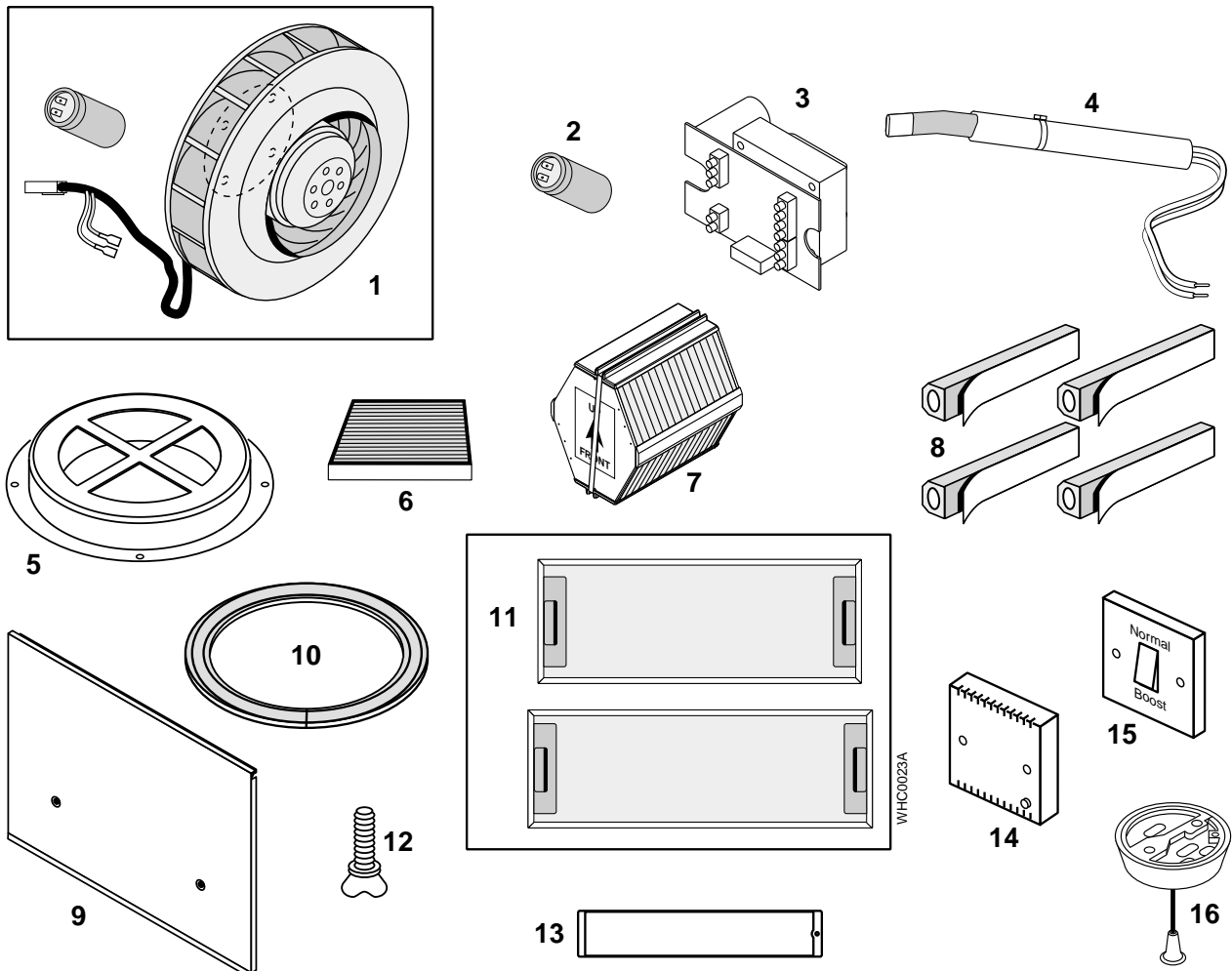

Fig. 28

Key No.	Spares Part No.	Description
1	372730	Fan assembly c.w. capacitor
2	372731	Capacitor
3	372732	Controller
4	372733	Overheat thermostat
5	372734	Fire damper
6	372735	Inlet duct filter
7	372736	Heat exchanger
8	372737	Heat exchanger seals (4 off)
9	372739	Outer door assembly
10	372741	Cooker hood seal
11	372743	Cooker hood filters (set of two)
12	372748	M5 wing screw
13	372777	Light Cover
Optional extras		
14	370254	Humidity sensor HS6
15	370495	Normal/boost switch NBSW
16	370278	Normal/boost switch PCSW

