

# VENT-AXIA QUADRA SQUARE MIXED FLOW FANS WIRING DIAGRAMS

## SINGLE PHASE FAN CONNECTED TO A D.O.L. STARTER

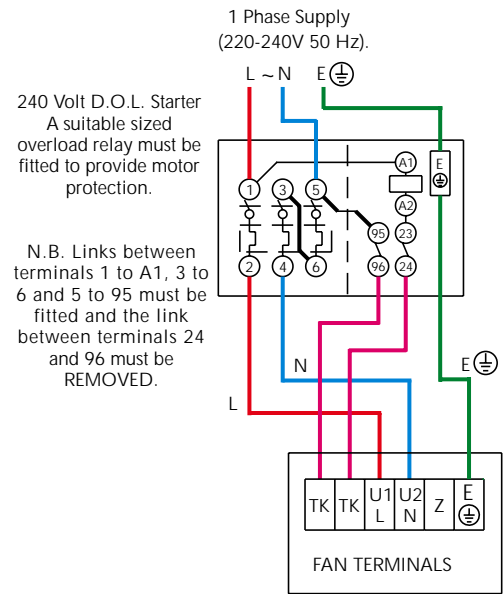

MFQ 350/4/1 MFQ 350/6/1  
MFQ 400/4/1 MFQ 400/6/1  
MFQ 450/4/1 MFQ 450/6/1  
MFQ 500/4/1 MFQ 500/6/1

## SINGLE PHASE FAN CONNECTED TO A 2.5 AMP ELECTRONIC SPEED CONTROLLER

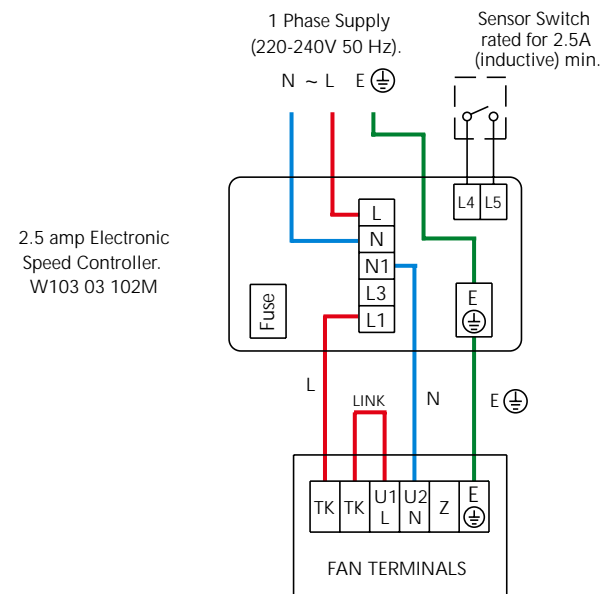

MFQ 350/4/1 MFQ 350/6/1  
MFQ 400/4/1 MFQ 400/6/1  
MFQ 450/4/1 MFQ 450/6/1  
MFQ 500/4/1 MFQ 500/6/1

## SINGLE PHASE FAN CONNECTED TO A 3.0, 6.0 OR 10.0 AMP ELECTRONIC SPEED CONTROLLER

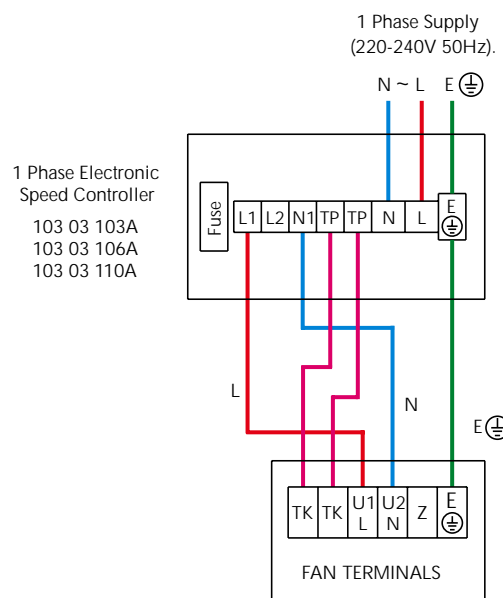

MFQ 350/4/1 MFQ 350/6/1  
MFQ 400/4/1 MFQ 400/6/1  
MFQ 450/4/1 MFQ 450/6/1  
MFQ 500/4/1 MFQ 500/6/1

## SINGLE PHASE FAN CONNECTED TO A 3.0, 5.0 OR 7.5 AMP AUTO TRANSFORMER SPEED CONTROLLER

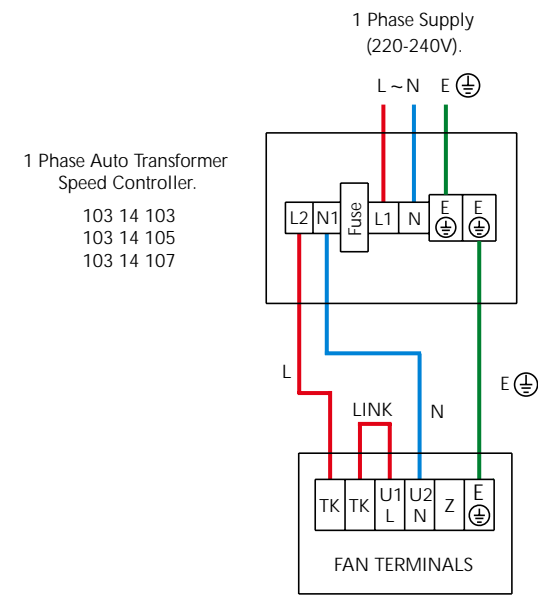

MFQ 350/4/1 MFQ 350/6/1  
MFQ 400/4/1 MFQ 400/6/1  
MFQ 450/4/1 MFQ 450/6/1  
MFQ 500/4/1 MFQ 500/6/1

# QUADRA SQUARE MIXED FLOW FANS WIRING DIAGRAMS

## THREE PHASE FAN CONNECTED TO A 415V COIL D.O.L. STARTER

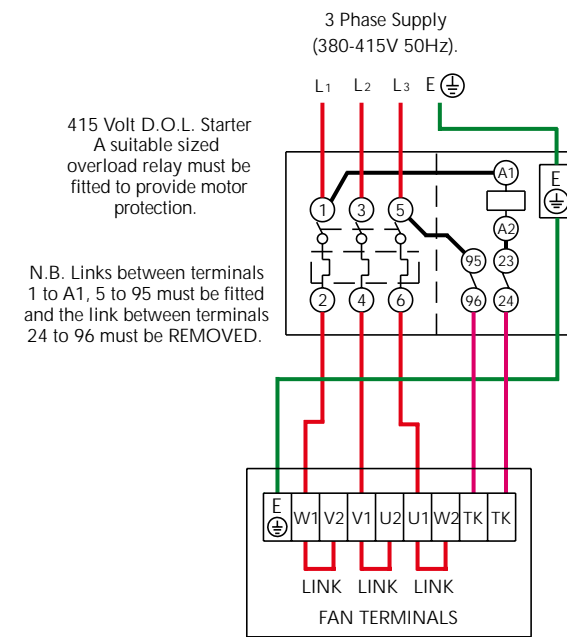

MFQ 400/4/3  
MFQ 450/4/3  
MFQ 500/4/3

## THREE PHASE FAN CONNECTED TO A 240V COIL D.O.L. STARTER

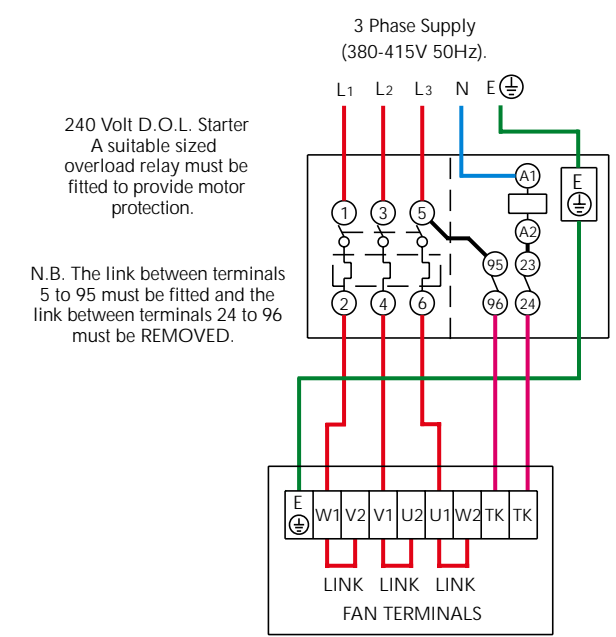

MFQ 400/4/3  
MFQ 450/4/3  
MFQ 500/4/3

## THREE PHASE FAN CONNECTED TO A 1.4, 4.0 OR 7.0 AMP AUTO TRANSFORMER SPEED CONTROLLER

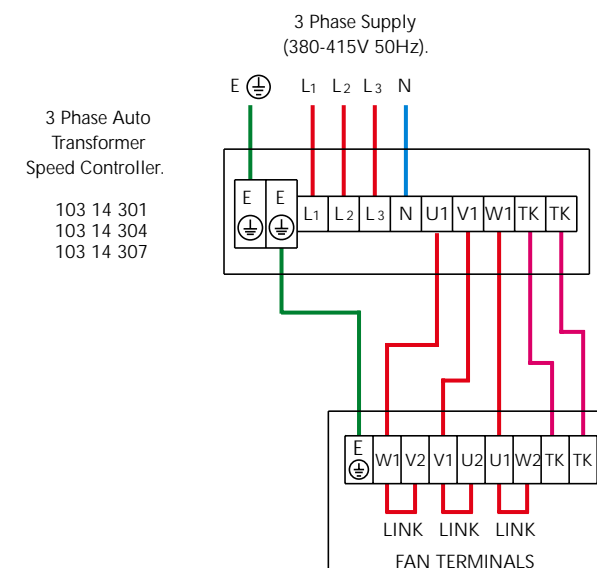

MFQ 400/4/3  
MFQ 450/4/3  
MFQ 500/4/3

# VENT-AXIA QUADRA SQUARE MIXED FLOW FANS WIRING DIAGRAMS

# QUADRA SQUARE MIXED FLOW FANS WIRING DIAGRAMS

## THREE PHASE FAN CONNECTED TO A 415V COIL D.O.L. STARTER

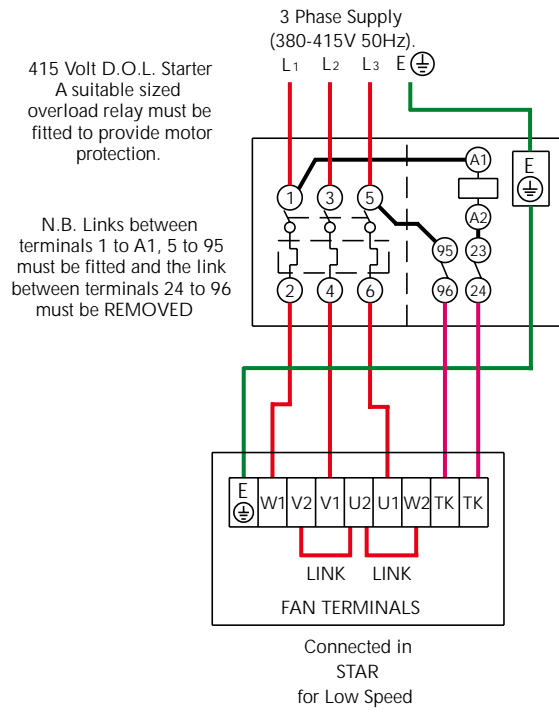

MFQ 400/6/3  
MFQ 450/6/3  
MFQ 500/6/3

## THREE PHASE FAN CONNECTED TO A 240V COIL D.O.L. STARTER

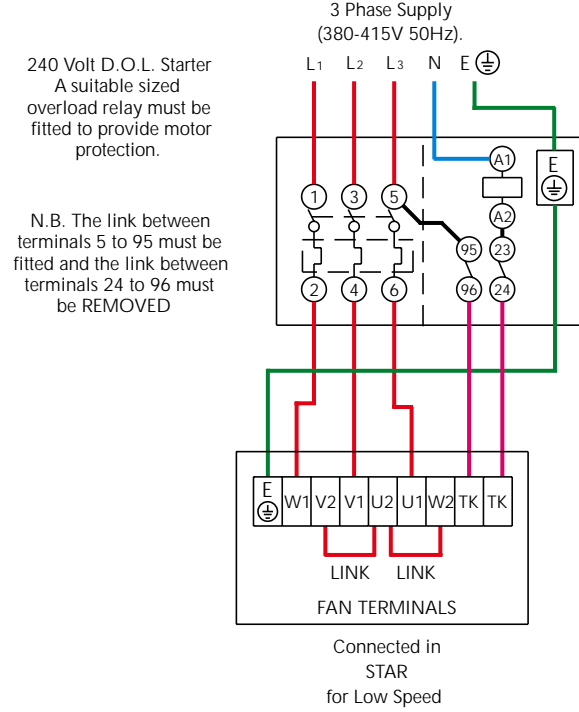

MFQ 400/6/3  
MFQ 450/6/3  
MFQ 500/6/3

## THREE PHASE FAN CONNECTED TO A 415V COIL D.O.L. STARTER

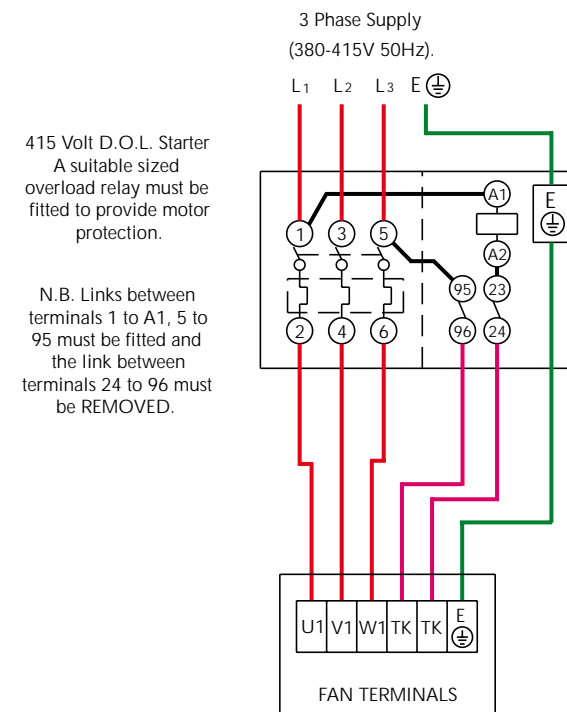

MFQ 560/4/3 MFQ 560/6/3

## THREE PHASE FAN CONNECTED TO A 240V COIL D.O.L. STARTER

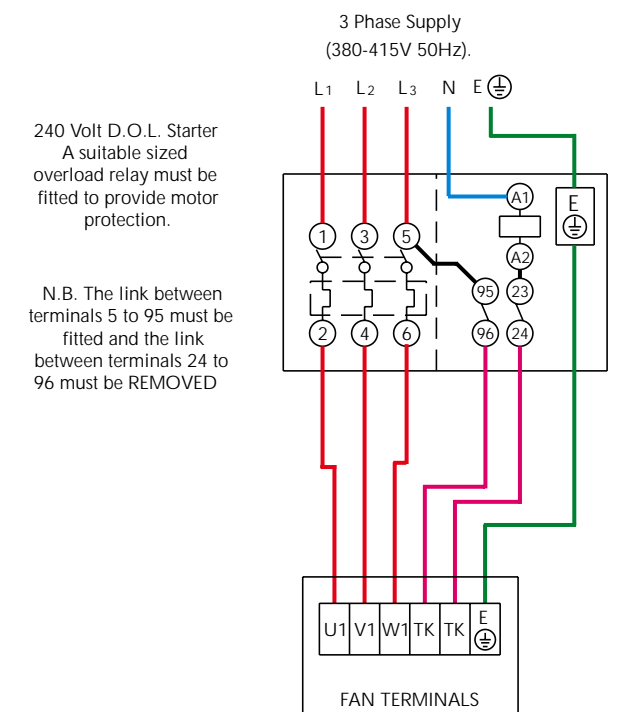

MFQ 560/4/3 MFQ 560/6/3

## THREE PHASE FAN CONNECTED TO A 1.4, 4.0 OR 7.0 AMP AUTO TRANSFORMER SPEED CONTROLLER

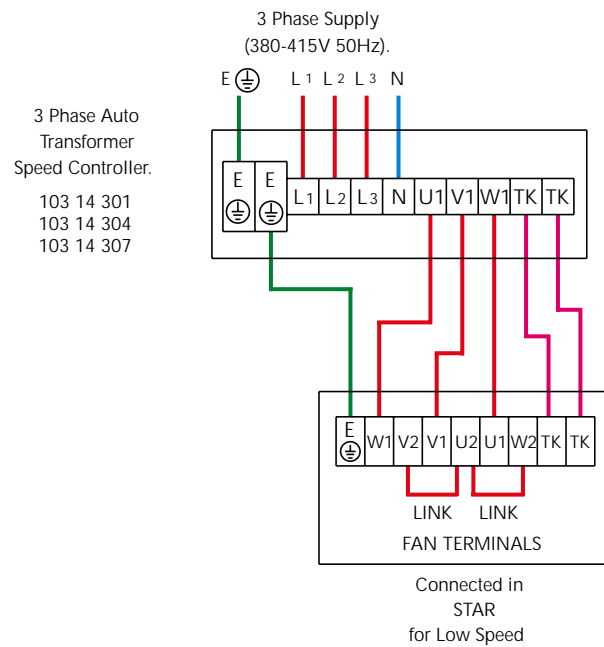

MFQ 400/6/3  
MFQ 450/6/3  
MFQ 500/6/3

## THREE PHASE FAN CONNECTED TO A 4.0 OR 7.0 AMP AUTO TRANSFORMER SPEED CONTROLLER

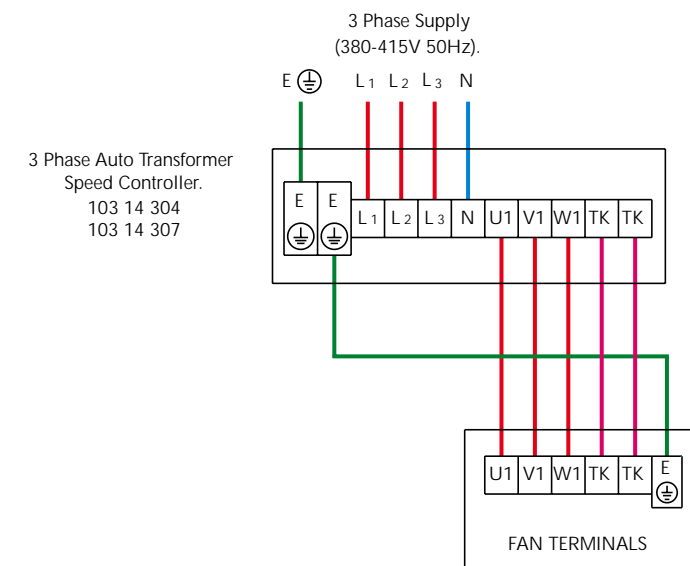

MFQ 560/4/3 MFQ 560/6/3