

VENT-AXIA LONG CASE AXIAL FANS (LC)



The Long Case Axial range of fans incorporates manually adjustable pitch impellers which provide a comprehensive range of duties offering high performance and pressure characteristics. Available in twelve sizes ranging from 315 to 1250mm diameter and performances from 0.24m³/s to 38m³/s (864m³/h to 136,800m³/h) with pressure development up to 1250Pa. The casing is constructed from rolled steel plate complete with flanges and protected with a tough, galvanised finish.

The Long Case Axial range has a range of accessories available which include: Axial Ancillary Pack, Cased Axial Attenuator, Mounting Feet, Wire Inlet Guard, Coupling Flange and Speed Controllers.



MOTORS

The motors are specially selected for optimum performance and efficiency. Ball bearings are greased for life and

allow the fan to be installed at any angle. Suitable for continuous operation in relative humidity up to 95%. Motors are protected to **IP55** against dust and water jets complying with **BS EN 60529**. They have ribbed aluminium body castings for efficient cooling. Motor insulation is Class 'F' (from -35°C to +54°C). Star/delta starting is recommended for motor output above 4kW.

SOUND LEVELS

All measurements of the sound that the fans generate have been taken strictly in accordance with **BS 848** part 2, test method 1. Published sound power level spectra figures are dBA with a reference of 10⁻¹² Watts(1 Pico watt).

MOTOR SUPPORT ARMS

Motors are mounted by means of specially designed support arms which act as an air straightener that helps minimise the turbulence and maximise performance, whilst ensuring quiet operation.

AXIAL IMPELLERS

Impeller blades are clamped in a split cast aluminium hub, with a keywayed mild steel insert enabling positive locking of the impeller assembly to the motor shaft, this also allows manual adjustment of the pitch angle giving a wide selection of performance details.

- ✓ Motors protected to **IP55**.
- ✓ Motor insulation Class 'F'.
- ✓ Maximum ambient temp. 54°C.
- ✓ Speed controllable via transformer or inverter (see pages 78, 79 and 83).
- ✓ **IP55** terminal box.
- ✓ Adjustable factory set die cast aluminium impeller.
- ✓ Suitable for relative humidity levels up to 95% R.H.
- ✓ Manufactured to **BS EN ISO 9001**.
- ✓ Performance tested to **BS 848 parts 1, 2 and ISO 5801**.
- ✓ **2 Year Guarantee**.

TERMINAL BOX

To **IP55**, protected against dust and water jets from any angle, allowing outside applications.

DECLARATION OF CONFORMITY

All models are supplied with an EC Declaration of Conformity as defined by the EC Council Directive on Machinery 98/37/EC. This declares that all the models, on the basis of their design and construction in the form brought onto the market by Vent-Axia, are in accordance with the Machinery Directive.

ELECTRICAL

Single phase 220-240V 50/Hz. Capacitor start and run. Three phase 380-415V/50Hz. Protection of the motor must be provided by an overload current sensing device (eg. D.O.L Starter or Star/Delta starter where appropriate) or the guarantee will be invalidated. All models are available with 4 pole motors for 315 up to 1250mm with additional 2 pole motors available from 315 up to 630mm.

LONG CASE AXIAL FANS 2 POLE PERFORMANCE GUIDE LC31A2-LC40A2

Red tabulations indicate a stock fan with a preset pitch angle. Black tabulations indicate the duty range of the preset fans in 2° increment. The impellers will be factory set and dispatched within two days.

	Phase	Pitch Angle	m³/s @ Static Pressure (Pa)							dBA @ 3m	
			0	50	100	150	200	250	300		400
LC31A 2/	1 & 3	8°	0.47	0.44	0.42	0.39	0.35	0.30	0.24	68	
LC 31A 2/	1 & 3	10°	0.56	0.53	0.50	0.46	0.42	0.37	0.29	68	
LC 31A 2/	1 & 3	12°	0.62	0.60	0.59	0.56	0.50	0.42	0.35	68	
LC 31A 2/	1 & 3	14°	0.69	0.68	0.66	0.62	0.58	0.50		66	
LC 31A 2/	1 & 3	16°	0.78	0.75	0.72	0.69	0.64	0.57		64	
LC 31A 2/	1 & 3	18°	0.84	0.82	0.78	0.74	0.69	0.61		64	
LC 31A 2/	1 & 3	20°	0.88	0.86	0.84	0.82	0.76	0.68		65	
LC 31A 2/	1 & 3	22°	0.96	0.93	0.90	0.86	0.82	0.74	0.63	66	
LC 31A 2/	1 & 3	24°	1.04	1.01	0.97	0.94	0.89	0.81	0.73	66	
LC 31A 2/	1 & 3	26°	1.10	1.07	1.03	0.99	0.94	0.87	0.76	66	
LC 31A 2/	1 & 3	28°	1.16	1.13	1.09	1.04	0.99	0.91	0.82	67	
LC 31A 2/	1 & 3	30°	1.24	1.19	1.14	1.08	1.02	0.95	0.84	68	
LC 31A 2/	1 & 3	32°	1.30	1.25	1.19	1.13	1.07	0.99	0.88	68	
LC 35A 2/	1 & 3	8°	0.78	0.73	0.67	0.62	0.55	0.48	0.41	68	
LC 35A 2/	1 & 3	10°	0.88	0.83	0.78	0.70	0.65	0.57	0.47	69	
LC 35A 2/	1 & 3	12°	0.99	0.92	0.85	0.78	0.70	0.63	0.54	69	
LC 35A 2/	1 & 3	14°	1.15	1.07	1.00	0.98	0.86	0.78	0.67	69	
LC 35A 2/	1 & 3	16°	1.22	1.16	1.08	1.03	0.97	0.90	0.79	69	
LC 35A 2/	1 & 3	18°	1.34	1.26	1.19	1.12	1.05	0.97	0.87	69	
LC 35A 2/	1 & 3	20°	1.37	1.32	1.27	1.19	1.13	1.06	0.95	64	
LC 35A 2/	1 & 3	22°	1.51	1.43	1.38	1.32	1.25	1.18	1.05	65	
LC 35A 2/	1 & 3	24°	1.64	1.56	1.47	1.40	1.33	1.25	1.16	66	
LC 35A 2/	1 & 3	26°	1.72	1.65	1.59	1.51	1.44	1.36	1.22	67	
LC 35A 2/	1 & 3	28°	1.83	1.76	1.68	1.59	1.50	1.41	1.31	67	
LC 35A 2/	1 & 3	30°	1.93	1.83	1.76	1.68	1.60	1.51	1.41	68	
LC 35A 2/	1 & 3	32°	2.02	1.93	1.84	1.76	1.67	1.58	1.47	69	
LC 40A 2/	1 & 3	8°	1.12	1.06	1.00	0.94	0.87	0.80	0.72	0.53	74
LC 40A 2/	1 & 3	10°	1.26	1.20	1.15	1.06	0.99	0.93	0.85	0.63	74
LC 40A 2/	1 & 3	12°	1.42	1.34	1.27	1.18	1.10	1.02	0.93	0.74	74
LC 40A 2/	1 & 3	14°	1.65	1.56	1.49	1.37	1.30	1.23	1.15	0.90	74
LC 40A 2/	1 & 3	16°	1.75	1.69	1.60	1.52	1.47	1.40	1.32	1.08	74
LC 40A 2/	1 & 3	18°	1.92	1.83	1.74	1.68	1.59	1.51	1.42	1.18	74
LC 40A 2/	1 & 3	20°	1.96	1.91	1.87	1.75	1.69	1.62	1.54	1.30	69
LC 40A 2/	1 & 3	22°	2.16	2.07	2.01	1.95	1.87	1.80	1.71	1.43	69
LC 40A 2/	1 & 3	24°	2.35	2.25	2.15	2.06	1.99	1.91	1.82	1.62	70
LC 40A 2/	1 & 3	26°	2.46	2.39	2.31	2.23	2.14	2.06	1.97	1.69	71
LC 40A 2/	1 & 3	28°	2.62	2.54	2.45	2.36	2.26	2.16	2.05	1.83	71

LONG CASE AXIAL FANS 2 POLE PERFORMANCE GUIDE LC45A2-LC63A2

Red tabulations indicate a stock fan with a preset pitch angle. Black tabulations indicate the duty range of the preset fans in 2° increment. The impellers will be factory set and dispatched within two days.

	Phase	Pitch Angle	m³/s @ Static Pressure (Pa)										dBA @ 3m	
			0	50	100	150	200	250	300	400	500	600		700
LC45A2/	3/	8°	1.67	1.58	1.49	1.41	1.33	1.25	1.17	1.00	0.82	0.60	79	
LC45A2/	3/	10°	1.87	1.80	1.74	1.63	1.55	1.48	1.40	1.24	1.05	0.79	79	
LC45A2/	3/	12°	2.14	2.05	1.97	1.88	1.81	1.71	1.62	1.43	1.24	0.97	79	
LC45A2/	3/	14°	2.29	2.23	2.16	2.08	2.01	1.94	1.85	1.67	1.47	1.16	79	
LC45A2/	3/	16°	2.59	2.49	2.40	2.31	2.21	2.11	2.02	1.84	1.63	1.36	79	
LC45A2/	3/	18°	2.75	2.67	2.58	2.46	2.36	2.27	2.19	1.98	1.75		74	
LC45A2/	3/	20°	2.92	2.84	2.76	2.67	2.59	2.51	2.41	2.19	1.91		75	
LC45A2/	3/	22°	3.13	3.03	2.93	2.83	2.75	2.68	2.58	2.36	2.08		76	
LC45A2/	3/	24°	3.28	3.17	3.07	3.00	2.92	2.85	2.76	2.54	2.22		76	
LC50A2/	3/	8°	2.23	2.15	2.08	2.04	1.99	1.94	1.86	1.71	1.61	1.50	1.35	78
LC50A2/	3/	10°	2.48	2.44	2.40	2.36	2.31	2.24	2.16	2.04	1.91	1.76	1.60	78
LC50A2/	3/	12°	2.79	2.74	2.69	2.63	2.57	2.51	2.45	2.33	2.24	2.09	1.91	78
LC50A2/	3/	14°	3.10	3.03	2.97	2.90	2.82	2.75	2.71	2.62	2.49	2.35	2.21	78
LC50A2/	3/	16°	3.47	3.39	3.32	3.26	3.19	3.12	3.05	2.89	2.73	2.57	2.42	78
LC50A2/	3/	18°	3.67	3.60	3.54	3.49	3.43	3.36	3.28	3.14	2.99	2.83	2.68	78
LC50A2/	3/	20°	3.95	3.88	3.81	3.74	3.68	3.61	3.55	3.41	3.24	3.06	2.88	78
LC50A2/	3/	22°	4.26	4.22	4.16	4.09	4.02	3.95	3.88	3.74	3.56	3.36	3.17	78
LC50A2/	3/	24°	4.61	4.53	4.48	4.42	4.35	4.29	4.23	4.08	3.90	3.71	3.51	80
LC50A2/	3/	26°	4.48	4.78	4.71	4.65	4.57	4.48	4.40	4.23	4.07	3.86	3.64	80

Phase	Phase	Pitch Angle	m³/s @ Static Pressure (Pa)										dBA @ 3m	
			0	100	200	300	400	500	600	700	800	900		1000
LC56A2/	3/	8°	3.19	2.94	2.85	2.74	2.57	2.40	2.30	2.19	2.03	1.86		82
LC56A2/	3/	10°	3.48	3.39	3.30	3.16	3.00	2.86	2.72	2.56	2.39	2.21		82
LC56A2/	3/	12°	3.92	3.80	3.68	3.54	3.40	3.27	3.18	3.03	2.84	2.63		82
LC56A2/	3/	14°	4.36	4.20	4.05	3.88	3.79	3.68	3.54	3.38	3.23	3.04		82
LC56A2/	3/	16°	4.88	4.70	4.56	4.41	4.24	4.06	3.88	3.70	3.53	3.36		82
LC56A2/	3/	18°	5.16	5.00	4.89	4.74	4.57	4.42	4.25	4.07	3.90	3.72		82
LC56A2/	3/	20°	5.55	5.39	5.24	5.10	4.95	4.79	4.60	4.40	4.20	4.00		82
LC56A2/	3/	22°	5.98	5.87	5.73	5.57	5.42	5.25	5.06	4.84	4.62	4.41		82
LC56A2/	3/	24°	6.48	6.32	6.19	6.05	5.90	5.73	5.54	5.32	5.10	4.88		83
LC63A2/	3/	8°	4.48	4.31	4.14	3.97	3.80	3.63	3.57	3.55	3.31	2.90	2.47	80
LC63A2/	3/	10°	5.20	5.00	4.81	4.61	4.43	4.25	4.09	3.87	3.62	3.37	3.11	81
LC63A2	/3/	12°	5.72	5.56	5.40	5.23	5.03	4.80	4.61	4.45	4.28	4.05	3.80	81
LC63A2/	3/	14°	6.24	6.05	5.86	5.68	5.53	5.38	5.22	5.04	4.76	4.49	4.23	81
LC63A2/	3/	16°	6.86	6.69	6.53	6.35	6.19	5.98	5.76	5.52	5.30	5.02	4.72	82

LONG CASE AXIAL FANS 4 POLE PERFORMANCE GUIDE LC31A4-LC35A4

Red tabulations indicate a stock fan with a preset pitch angle. Black tabulations indicate the duty range of the preset fans in 2° increment. The impellers will be factory set and dispatched within two days.

	Phase	Pitch Angle	m³/s @ Static Pressure (Pa)										dBA @ 3m
			0	10	20	30	40	50	60	70	80	90	
LC31A 4/	1 & 3/	8°	0.24	0.22	0.21	0.20	0.19	0.17	0.15	0.13	0.10		53
LC31A 4/	1 & 3/	10°	0.28	0.27	0.26	0.24	0.22	0.21	0.19	0.16	0.13		53
LC31A 4/	1 & 3/	12°	0.31	0.30	0.29	0.28	0.27	0.25	0.22	0.19	0.16		53
LC31A 4/	1 & 3/	14°	0.35	0.34	0.33	0.32	0.31	0.29	0.26	0.23			48
LC31A 4/	1 & 3/	16°	0.39	0.38	0.36	0.35	0.34	0.32	0.30	0.26			48
LC31A 4/	1 & 3/	18°	0.42	0.41	0.40	0.39	0.37	0.34	0.31	0.28			48
LC31A 4/	1 & 3/	20°	0.44	0.43	0.42	0.41	0.40	0.38	0.35	0.30			48
LC31A 4/	1 & 3/	22°	0.48	0.47	0.46	0.44	0.43	0.41	0.38	0.34			50
LC31A 4/	1 & 3/	24°	0.52	0.51	0.49	0.47	0.46	0.44	0.41	0.39			50
LC31A 4/	1 & 3/	26°	0.55	0.54	0.52	0.51	0.49	0.47	0.44	0.41			50
LC31A 4/	1 & 3/	28°	0.58	0.57	0.55	0.53	0.51	0.49	0.46	0.43			50
LC31A 4/	1 & 3/	30°	0.62	0.60	0.58	0.56	0.54	0.51	0.48	0.45			52
LC31A 4/	1 & 3/	32°	0.65	0.63	0.61	0.58	0.56	0.53	0.50	0.47			52
LC35A 4/	1 & 3/	8°	0.39	0.37	0.35	0.33	0.30	0.28	0.25	0.22	0.18	0.13	54
LC35A 4/	1 & 3/	10°	0.44	0.42	0.40	0.37	0.35	0.32	0.29	0.26	0.21	0.16	54
LC35A 4/	1 & 3/	12°	0.49	0.47	0.44	0.41	0.38	0.35	0.32	0.29	0.25	0.19	54
LC35A 4/	1 & 3/	14°	0.57	0.54	0.52	0.48	0.45	0.43	0.40	0.36	0.31	0.24	54
LC35A 4/	1 & 3/	16°	0.61	0.59	0.56	0.53	0.51	0.49	0.46	0.42	0.37	0.30	54
LC35A 4/	1 & 3/	18°	0.67	0.64	0.61	0.58	0.55	0.52	0.49	0.45	0.41	0.35	54
LC35A 4/	1 & 3/	20°	0.69	0.67	0.65	0.61	0.59	0.56	0.54	0.50	0.45		49
LC35A 4/	1 & 3/	22°	0.76	0.72	0.70	0.68	0.65	0.62	0.60	0.56	0.49		49
LC35A 4/	1 & 3/	24°	0.82	0.79	0.75	0.72	0.69	0.66	0.63	0.60	0.56		50
LC35A 4/	1 & 3/	26°	0.86	0.83	0.81	0.78	0.75	0.72	0.69	0.64	0.58		51
LC35A 4/	1 & 3/	28°	0.91	0.89	0.86	0.82	0.79	0.75	0.71	0.67	0.64		51
LC35A 4/	1 & 3/	30°	0.96	0.92	0.89	0.87	0.83	0.80	0.76	0.72	0.68		52
LC35A 4/	1 & 3/	32°	1.01	0.97	0.94	0.90	0.87	0.83	0.80	0.76	0.72		52

LONG CASE AXIAL FANS 4 POLE PERFORMANCE GUIDE LC40A4-LC45A4

Red tabulations indicate a stock fan with a preset pitch angle. Black tabulations indicate the duty range of the preset fans in 2° increment. The impellers will be factory set and dispatched within two days.

Phase	Pitch Angle	m³/s @ Static Pressure (Pa)											dBA @ 3m	
		0	10	20	30	40	50	60	70	80	90	100		110
LC40A 4/ 1 & 3/	8°	0.56	0.53	0.51	0.49	0.46	0.43	0.40	0.37	0.34	0.31	0.26	0.20	58
LC40A4/ 1 & 3/	10°	0.63	0.60	0.58	0.56	0.52	0.50	0.47	0.44	0.40	0.36	0.32	0.24	58
LC40A 4/ 1 & 3/	12°	0.71	0.68	0.65	0.62	0.58	0.55	0.52	0.48	0.44	0.41	0.37	0.30	58
LC40A 4/ 1 & 3/	14°	0.82	0.79	0.76	0.72	0.67	0.65	0.62	0.60	0.55	0.51	0.45	0.38	58
LC40A 4/ 1 & 3/	16°	0.87	0.85	0.82	0.78	0.75	0.73	0.70	0.67	0.64	0.59	0.54	0.46	58
LC40A 4/ 1 & 3/	18°	0.96	0.92	0.89	0.86	0.83	0.80	0.76	0.73	0.69	0.64	0.59	0.53	58
LC40A 4/ 1 & 3/	20°	0.98	0.96	0.94	0.92	0.87	0.84	0.81	0.79	0.76	0.71	0.65		52
LC40A 4/ 1 & 3/	22°	1.08	1.04	1.02	0.99	0.97	0.94	0.91	0.87	0.84	0.79	0.72		52
LC40A 4/ 1 & 3/	24°	1.17	1.14	1.10	1.06	1.02	0.99	0.96	0.93	0.89	0.85	0.81		54
LC40A 4/ 1 & 3/	26°	1.23	1.20	1.17	1.14	1.11	1.07	1.04	1.00	0.97	0.91	0.84		55
LC40A 4/ 1 & 3/	28°	1.31	1.28	1.24	1.21	1.17	1.13	1.09	1.05	1.00	0.96	0.92		56
LC40A 4/ 1 & 3/	30°	1.38	1.33	1.29	1.26	1.23	1.20	1.16	1.12	1.07	1.03	0.99		56
LC40A 4/ 1 & 3/	32°	1.44	1.40	1.36	1.32	1.28	1.24	1.20	1.16	1.12	1.08	1.03		57

Phase	Pitch Angle	m³/s @ Static Pressure (Pa)										dBA @ 3m			
		0	25	50	75	100	125	150	175	200	225		250		
LC45A 4/ 1 & 3/	8°	0.84	0.74	0.67	0.58	0.50	0.41	0.30							63
LC45A 4/ 1 & 3/	10°	0.94	0.87	0.77	0.70	0.62	0.52	0.39							63
LC45A4/ 1 & 3/	12°	1.07	0.99	0.90	0.81	0.72	0.62	0.48							63
LC45A 4/ 1 & 3/	14°	1.15	1.08	1.01	0.93	0.84	0.74	0.58							63
LC45A 4/ 1 & 3/	16°	1.30	1.20	1.10	1.01	0.92	0.81	0.68							63
LC45A 4/ 1 & 3/	18°	1.38	1.29	1.18	1.10	0.99	0.87								58
LC45A 4/ 1 & 3/	20°	1.46	1.38	1.30	1.21	1.10	0.96								59
LC45A 4/ 1 & 3/	22°	1.57	1.47	1.38	1.29	1.18	1.04								60
LC45A 4/ 1 & 3/	24°	1.64	1.54	1.46	1.38	1.27	1.11								60
LC45A 4/ 1 & 3/	26°	1.72	1.63	1.55	1.47	1.37	1.26								61
LC45A 4/ 1 & 3/	28°	1.78	1.71	1.64	1.56	1.47	1.36								62
LC45A 4/ 1 & 3/	30°	1.87	1.78	1.70	1.62	1.52	1.43								63
LC45A 4/ 1 & 3/	32°	1.97	1.88	1.80	1.69	1.60	1.47								63

LONG CASE AXIAL FANS 4 POLE PERFORMANCE GUIDE LC50A4-LC63A4

Red tabulations indicate a stock fan with a preset pitch angle. Black tabulations indicate the duty range of the preset fans in 2° increment. The impellers will be factory set and dispatched within two days.

Phase	Pitch Angle	m³/s @ Static Pressure (Pa)										dBA @ 3m			
		0	25	50	75	100	125	150	175	200	225		250		
LC50A 4/ 1 & 3/	8°	1.14	1.04	1.00	0.93	0.85	0.81	0.75	0.68						62
LC50A 4/ 1 & 3/	10°	1.24	1.20	1.15	1.08	1.02	0.95	0.88	0.80						62
LC50A 4/ 1 & 3/	12°	1.40	1.34	1.29	1.22	1.16	1.12	1.04	0.95						62
LC50A 4/ 1 & 3/	14°	1.55	1.48	1.41	1.36	1.31	1.25	1.18	1.11						62
LC50A 4/ 1 & 3/	16°	1.74	1.66	1.60	1.52	1.45	1.37	1.29	1.21						62
LC50A 4/ 1 & 3/	18°	1.84	1.77	1.72	1.64	1.57	1.49	1.42	1.34						62
LC50A 4/ 1 & 3/	20°	1.98	1.90	1.84	1.78	1.70	1.62	1.53	1.44						62
LC50A 4/ 1 & 3/	22°	2.13	2.03	2.01	1.94	1.87	1.78	1.68	1.59						62
LC50A 4/ 1 & 3/	24°	2.31	2.24	2.18	2.11	2.04	1.95	1.85	1.76						64
LC50A 4/ 1 & 3/	26°	2.42	2.36	2.28	2.20	2.12	2.04	1.93	1.82						64
LC50A 4/ 1 & 3/	28°	2.56	2.47	2.39	2.30	2.21	2.13	2.04	1.94						65

Phase	Pitch Angle	m³/s @ Static Pressure (Pa)										dBA @ 3m			
		0	50	100	150	200	250	300	350	400	450				
LC56A 4/ 1 & 3/	8°	1.59	1.42	1.28	1.15	1.02									66
LC56A 4/ 1 & 3/	10°	1.74	1.65	1.50	1.36	1.19									66
LC56A 4/ 1 & 3/	12°	1.96	1.84	1.70	1.59	1.42									66
LC56A 4/ 1 & 3/	14°	2.18	2.03	1.90	1.77	1.61									66
LC56A 4/ 1 & 3/	16°	2.44	2.28	2.12	1.94	1.77									66
LC56A 4/ 1 & 3/	18°	2.58	2.44	2.28	2.12	1.95									66
LC56A 4/ 1 & 3/	20°	2.77	2.62	2.48	2.30	2.10									66
LC56A 4/ 1 & 3/	22°	2.99	2.87	2.71	2.53	2.30									66
LC56A 4/ 1 & 3/	24°	3.24	3.10	2.95	2.77	2.55									66
LC56A 4/ 1 & 3/	26°	3.40	3.25	3.06	2.89	2.65									68
LC63A 4/ 1 & 3/	8°	2.24	2.07	1.90	1.79	1.66	1.23	0.82							66
LC63A 4/ 1 & 3/	10°	2.60	2.41	2.22	2.04	1.81	1.56	1.16							66
LC63A 4/ 1 & 3/	12°	2.86	2.70	2.52	2.31	2.14	1.90	1.55							66
LC63A 4/ 1 & 3/	14°	3.12	2.93	2.76	2.61	2.38	2.12	1.76							66
LC63A 4/ 1 & 3/	16°	3.43	3.27	3.10	2.88	2.65	2.36	1.86							66
LC63A 4/ 1 & 3/	18°	3.77	3.57	3.38	3.19	3.01	2.67	2.12							66
LC63A 4/ 1 & 3/	20°	4.03	3.85	3.65	3.48	3.25	2.88	2.33							67
LC63A 4/ 1 & 3/	22°	4.29	4.09	3.85	3.64	3.40	3.05	2.59							67
LC63A 4/ 3/	24°	4.68	4.43	4.24	4.04	3.80	3.51	3.01							68
LC63A 4/ 3/	26°	5.04	4.81	4.56	4.32	4.12	3.79	3.37							68
LC63A 4/ 3/	28°	5.30	5.11	4.87	4.62	4.35	4.07	3.63							69
LC63A 4/ 3/	30°	5.56	5.34	5.08	4.84	4.63	4.24	3.76							69

LONG CASE AXIAL FANS 4 POLE PERFORMANCE GUIDE LC71A4-LC90A4

Red tabulations indicate a stock fan with a preset pitch angle. Black tabulations indicate the duty range of the preset fans in 2° increment. The impellers will be factory set and dispatched within two days.

	Phase	Pitch Angle	m³/s @ Static Pressure (Pa)										dBA @ 3m		
			0	50	100	150	200	250	300	350	400	450			
LC71A 4 /	3 /	8°	3.36	3.15	2.94	2.76	2.57	2.36	2.10	1.78	1.33				77
LC71A 4 /	3 /	10°	3.82	3.54	3.27	3.08	2.85	2.62	2.37	2.06	1.56				77
LC71A 4 /	3 /	12°	4.35	4.07	3.85	3.54	3.27	3.02	2.72	2.38	1.89				77
LC71A 4 /	3 /	14°	4.62	4.37	4.16	3.92	3.63	3.36	3.06	2.66	2.02				77
LC71A 4 /	3 /	16°	5.02	4.82	4.56	4.32	4.12	3.77	3.45	3.02	2.32				77
LC71A 4 /	3 /	18°	5.50	5.22	4.94	4.74	4.54	4.31	4.01						74
LC71A 4 /	3 /	20°	5.84	5.59	5.38	5.19	4.94	4.69	4.41						75
LC71A 4 /	3 /	22°	6.26	6.00	5.77	5.51	5.23	4.97	4.68						75
LC71A 4 /	3 /	24°	6.64	6.35	6.08	5.81	5.54	5.24	4.93	4.56					75
LC71A 4 /	3 /	26°	7.02	6.74	6.46	6.18	5.88	5.58	5.28	4.96					76
LC71A 4 /	3 /	28°	7.41	7.13	6.88	6.60	6.34	6.09	5.79	5.44					76
LC71A4 /	3 /	30°	7.67	7.44	7.13	6.85	6.57	6.27	5.99	5.70					77

	Phase	Pitch Angle	m³/s @ Static Pressure (Pa)										dBA @ 3m			
			0	100	200	300	400	500	600	700	800	900		1000		
LC80A 4 /	3 /	8°	4.81	4.33	3.91	3.47	2.87	1.98								81
LC80A 4 /	3 /	10°	5.46	4.84	4.35	3.84	3.29	2.33								81
LC80A 4 /	3 /	12°	6.22	5.61	4.99	4.44	3.75	2.81								81
LC80A 4 /	3 /	14°	6.61	6.07	5.54	4.90	4.22	2.96								81
LC80A 4 /	3 /	16°	7.27	6.69	6.14	5.53	4.80	3.44								81
LC80A 4 /	3 /	18°	7.78	7.18	6.74	6.25	5.58									78
LC80A 4 /	3 /	20°	8.35	7.77	7.37	6.81	6.18									79
LC80A 4 /	3 /	22°	8.96	8.38	7.83	7.21	6.55									79
LC80A 4 /	3 /	24°	9.50	8.85	8.26	7.62	6.92									79
LC80A 4 /	3 /	26°	10.04	9.42	8.77	8.11	7.42									80
LC80A 4 /	3 /	28°	10.60	10.00	9.39	8.81	8.14									80
LC90A 4 /	3 /	8°	6.81	6.34	5.71	5.11	4.56	3.89	2.99							80
LC90A 4 /	3 /	10°	8.14	7.22	6.62	6.08	5.53	4.98	3.74							81
LC90A 4 /	3 /	12°	8.81	8.14	7.24	6.72	5.99	5.25	4.37							81
LC90A 4 /	3 /	14°	9.80	9.04	8.33	7.54	6.91	6.22	5.29							81
LC90A 4 /	3 /	16°	10.53	9.87	9.12	8.39	7.68	6.96	6.13							82
LC90A 4 /	3 /	18°	11.49	10.74	10.08	9.39	8.69	7.95	6.97							82
LC90A 4 /	3 /	20°	11.98	11.40	10.70	10.08	9.39	8.66	7.74							82
LC90A 4 /	3 /	22°	13.02	12.37	11.69	10.95	10.29	9.61	8.53							82
LC90A 4 /	3 /	24°	14.09	13.27	12.75	12.12	11.09	10.06	9.08							83
LC90A 4 /	3 /	26°	15.12	14.29	13.47	12.65	11.84	11.02	10.04							83

LONG CASE AXIAL FANS 4 POLE MOTOR PERFORMANCE LC100A4-LC125A4

Green tabulations indicate fans available on request. Please contact your local Sales Office for delivery information.

	Phase	Pitch Angle	m³/s @ Static Pressure (Pa)									dBA @ 3m
			0	100	200	300	400	500	600	700	800	
LC100A4 /	3 /	8°	9.34	8.82	8.20	7.40	6.84	6.20	5.46	4.67		84
LC100A4 /	3 /	10°	11.17	10.14	9.41	8.75	8.16	7.55	6.94	5.65		85
LC100A4 /	3 /	12°	12.09	11.31	10.39	9.78	8.98	8.17	7.36	6.42		85
LC100A4 /	3 /	14°	13.44	12.56	11.78	10.93	10.14	9.43	8.67	7.66		85
LC100A4 /	3 /	16°	14.44	13.73	12.91	12.08	11.28	10.48	9.69	8.95		86
LC100A4 /	3 /	18°	15.76	14.91	14.16	13.42	12.65	11.87	11.07	10.06		86
LC100A4 /	3 /	20°	16.43	15.81	15.05	14.31	13.60	12.83	12.06	11.04		86
LC100A4 /	3 /	22°	17.86	17.16	16.38	15.62	14.78	14.07	13.36	12.26		86
LC100A4 /	3 /	24°	19.33	18.42	17.69	17.27	16.29	15.14	14.00	12.88		87
LC100A4 /	3 /	26°	20.74	19.81	18.91	18.00	17.09	16.18	15.28	14.22		88
LC100A4 /	3 /	28°	21.80	21.04	20.15	19.25	18.36	17.32	16.28	15.24		88

	Phase	Pitch Angle	m³/s @ Static Pressure (Pa)					dBA @ 3m		
			0	250	500	750	1000		1250	
LC125A4 /	3 /	8°	19.08	17.11	14.46	12.71	10.48	7.90		94
LC125A4 /	3 /	10°	21.37	19.13	16.73	14.10	12.05	9.17		94
LC125A4 /	3 /	12°	23.66	21.27	18.53	16.29	13.66	11.21		94
LC125A4 /	3 /	14°	25.19	23.50	20.15	17.91	15.41			92
LC125A4 /	3 /	16°	27.48	25.14	22.67	20.38	17.50			92
LC125A4 /	3 /	18°	30.53	28.13	25.82	23.29	20.52			92
LC125A4 /	3 /	20°	32.06	28.80	24.35	23.11	21.36			92
LC125A4 /	3 /	22°	36.13	33.27	30.82	28.21	25.59			92
LC125A4 /	3 /	24°	38.67	36.53	33.39	31.05	28.40			92



Motors protected to IP55 against dust and water jets, insulation Class 'F' (from -35°C to +55°C)



Composite cast aluminium axial impellers



Terminal box protected to IP55

VENT-AXIA LONG CASE AXIAL FANS SELECTION GUIDE

GUIDE TO LONG CASE AXIAL FAN SELECTION

The following selection charts are arranged as follows:-

Fan Diameter - 315, 400, 500, 630, 710, 800, 900, 1000, 1250
Fan Speed - 2 & 4 Pole Motors
Please note: 6 & 8 Pole Motors are available on request

Fan curves are shown in increments of 2° at nominal speeds of 2880 & 1440 rpm for 2 Pole & 4 Pole Motors respectively.

Please consult your Long Case Axial Fan Catalogue for details of Stock Fan Ranges.

All stocked fans have the impellers set at the maximum pitch angle relative to the motor power of the fan unit and are available for adjustment below the pre-set pitch angle (adjustment down in 2° intervals). These units will be factory set before despatch.

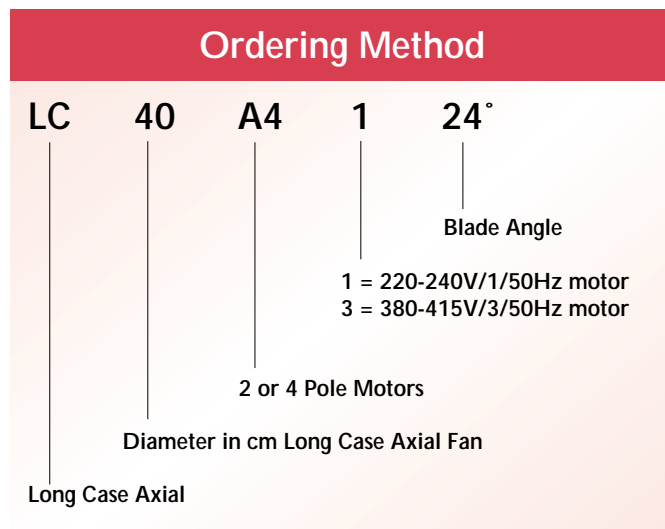

HOW TO USE AXIAL FLOW CURVES

Select the required volume from the values given on the horizontal axis marked inlet volume interpolating between the values as required. Project an imaginary line vertically from this point to a point which corresponds to the required pressure. This required pressure is found using the vertical axis values marked fan static pressure.

The point on the graph, where the required volume and pressure lines cross, is the selection point. From this point the pitch angle is read by following the nearest black performance curve line until the pitch angle(s) can be read at one end. Also from the selection point the total efficiency can be established. This is done by estimating the selection points position in relation to the nearest black lines with percentage figures.

Published sound power level spectra figures are dB with a reference of 10⁻¹² Watts (1 Pico watt).

The sound power level (dBW) and sound pressure level (dB) at a distance of three fan diameters can be read directly in a similar manner using the black dotted lines.

Sound pressure levels (dB) issued for Vent-Axia Long Cased fans are shown at a distance of three fan diameters from the fan, allowing for directivity. Sound pressure levels do not

provide an easy base for fan sound level comparison; it may not be immediately apparent, but it will be quite easily understood, that a 315mm sound pressure level of 60 dB can be quieter than, say, a 630mm fan at 60 dB. In the first case the sound level is measured at 3 x 315 to 945mm from the fan and in the second case 3 x 630 to 1890mm distance.

Presentation in terms of sound power, dBW, means that an absolute measure is given of the sound energy radiated, since this measure is entirely independent of the acoustic environment. Direct comparison can be made between different designs of fans for a given duty with differing speeds and diameters. To obtain the sound power level spectrum from the octave band mid-frequencies 63 to 8000 Hz, the constants shown at the foot of each performance chart should be subtracted from the sound power level (dBW) of the fan selected.

The values have been tested, using BS 848 Part 2, In Duct test method. This method of test is similar to the installation of an axial flow fan but seems to result in noise levels +3 to +5dB greater than would be determined by Free Field or Reverberant Field Testing.

The sound spectrum of the selected fan can be found by deducting the constants shown in the table under each fan graph.

LONG CASE AXIAL FANS PERFORMANCE CURVE SELECTION GUIDE

FAN SELECTION EXAMPLE

Duty required: 1.58m³/s @ 112 Pa

Select the graph where the duty point falls within the optimum efficiency area.

Plot the duty point on the performance curve. - See Example which shows a 500 dia 4 Pole fan at 20° pitch angle. This unit is available on a special made to order basis only.

The option is available of selecting a 20° or 22° Ex-Stock fan with reference to fan laws concerning the increase or decrease in resistance. See the tabulations in the Long Cased fan catalogue.

- A Duty point, 1.58m³/s
- B Calculated resistance 112 Pa
- C Sound Power Level
- D Total Efficiency Contours
- E Pitch Angle

LC50A4 / 1ph or 3ph /Blade Angle°

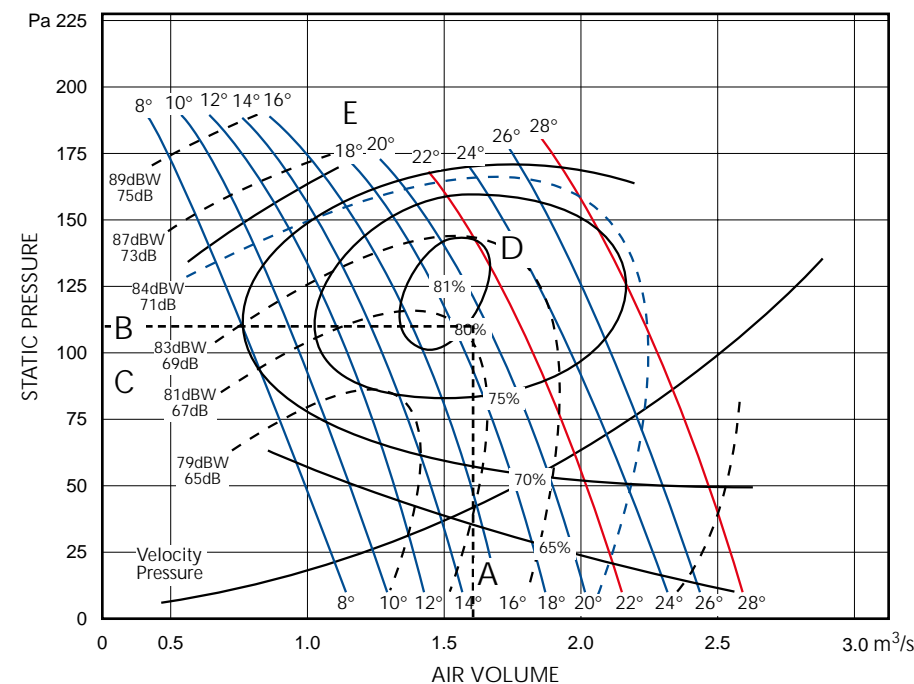

SOUND LEVEL SPECTRUM CORRECTION							
63	125	250	500	1000	2000	4000	8000
7	5	7	9	10	15	21	23

To obtain the sound spectrum in the octave bands 63 to 8000 Hz, subtract the constants shown under each performance chart from the dBW figure on the chart.

VENT-AXIA LONG CASE AXIAL FANS PERFORMANCE CURVES

To obtain the sound spectrum in the octave bands 63 to 8000 Hz, subtract the constants shown under each performance chart from the dBW figure on the chart.

LC31A2 / 1ph or 3ph

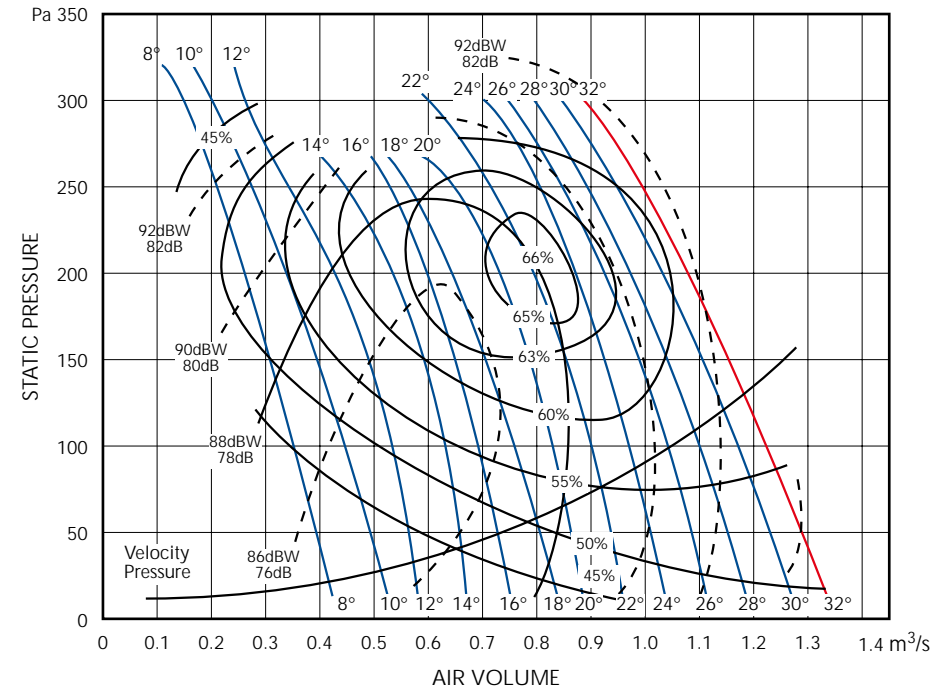

IN DUCT	OCTAVE BAND MID-FREQUENCY Hz (c/s)							
SPECTRUM	63	125	250	500	1000	2000	4000	8000
CONSTANTS	7	8	6	8	10	14	20	27

LC35A2 / 1ph or 3ph

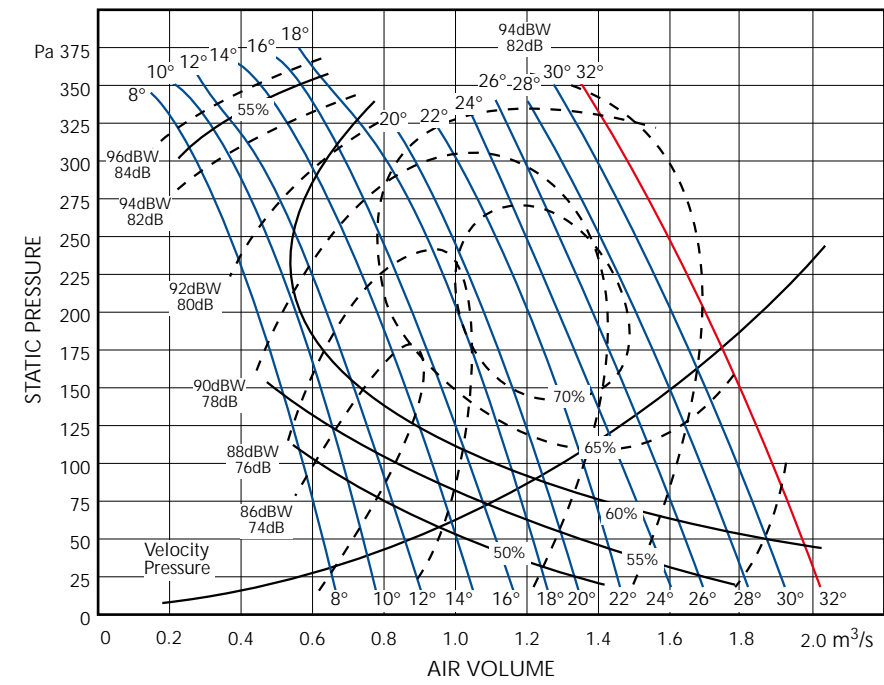

IN DUCT	OCTAVE BAND MID-FREQUENCY Hz (c/s)							
SPECTRUM	63	125	250	500	1000	2000	4000	8000
CONSTANTS	7	8	6	8	10	14	20	27

LC31A4 / 1ph or 3ph

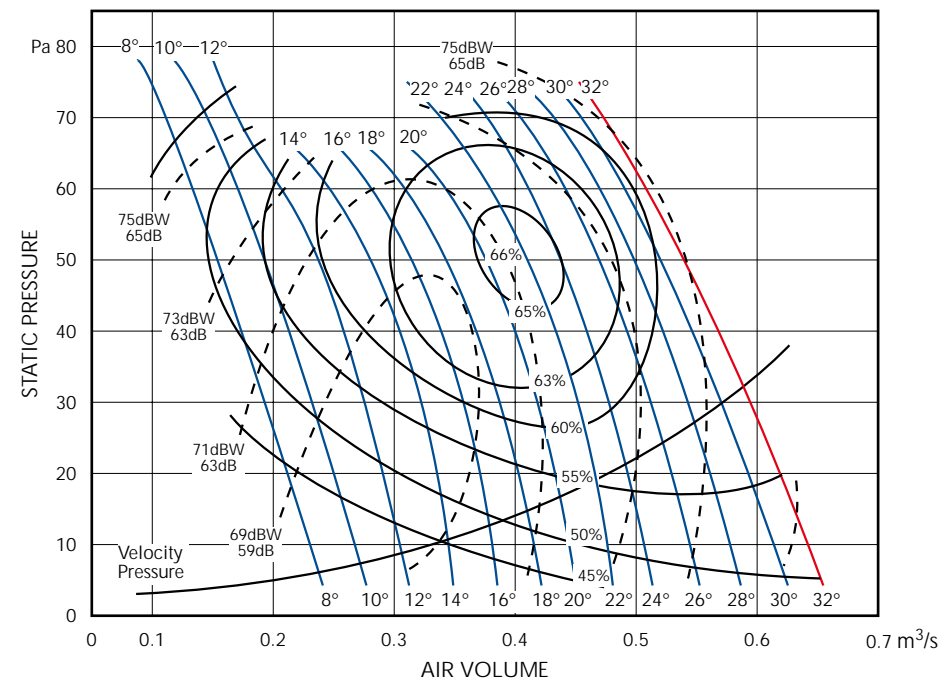

IN DUCT	OCTAVE BAND MID-FREQUENCY Hz (c/s)							
SPECTRUM	63	125	250	500	1000	2000	4000	8000
CONSTANTS	6	5	7	9	10	15	21	28

LC35A4 / 1ph or 3ph

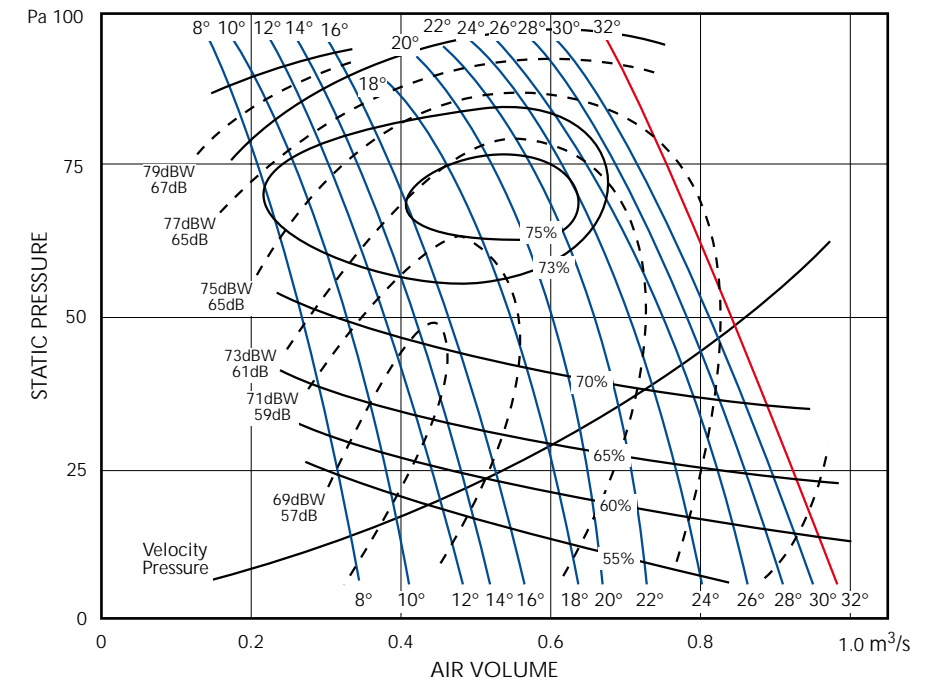

IN DUCT	OCTAVE BAND MID-FREQUENCY Hz (c/s)							
SPECTRUM	63	125	250	500	1000	2000	4000	8000
CONSTANTS	5	7	9	10	15	21	29	

LONG CASE AXIAL FANS PERFORMANCE CURVES

VENT-AXIA LONG CASE AXIAL FANS PERFORMANCE CURVES

To obtain the sound spectrum in the octave bands 63 to 8000 Hz, subtract the constants shown under each performance chart from the dBW figure on the chart.

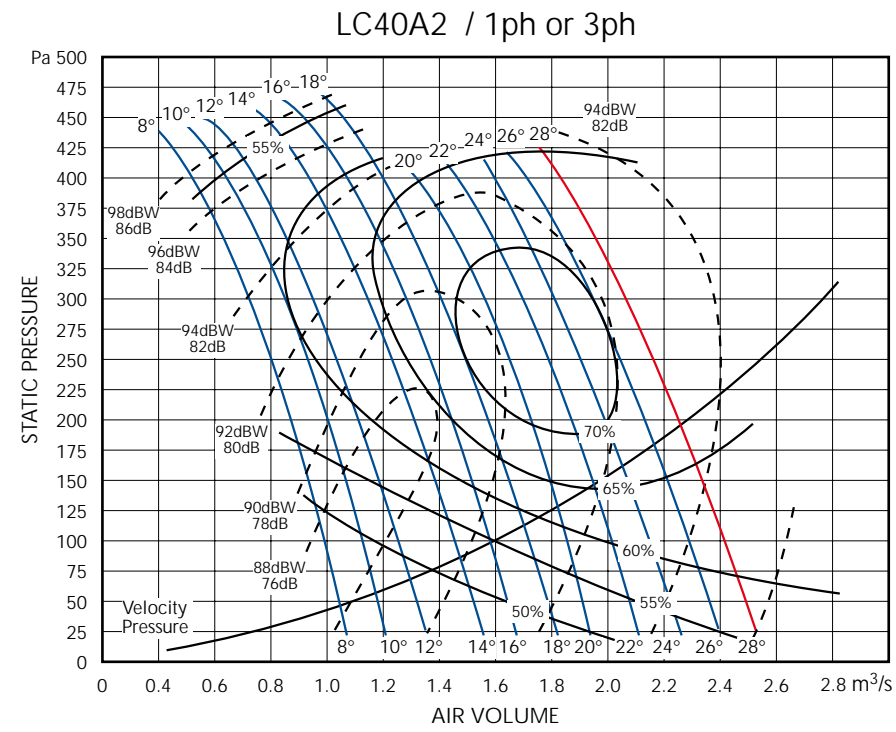

IN DUCT	OCTAVE BAND MID-FREQUENCY Hz (c/s)							
SPECTRUM	63	125	250	500	1000	2000	4000	8000
CONSTANTS	7	8	6	8	10	14	20	27

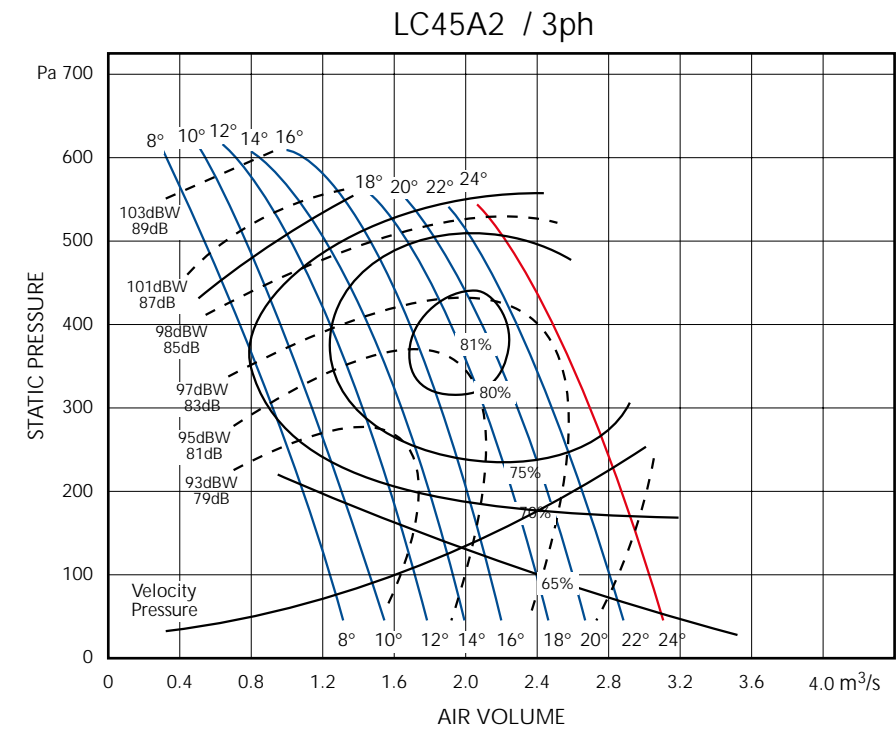

IN DUCT	OCTAVE BAND MID-FREQUENCY Hz (c/s)							
SPECTRUM	63	125	250	500	1000	2000	4000	8000
CONSTANTS	7	5	6	8	9	14	19	21

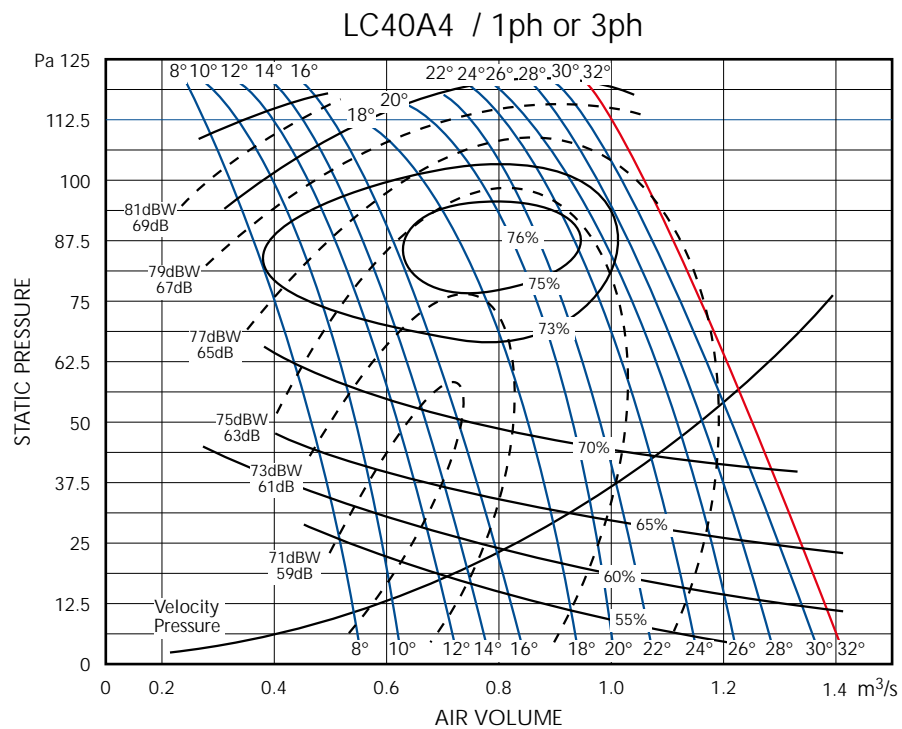

IN DUCT	OCTAVE BAND MID-FREQUENCY Hz (c/s)							
SPECTRUM	63	125	250	500	1000	2000	4000	8000
CONSTANTS	6	5	7	9	10	15	21	28

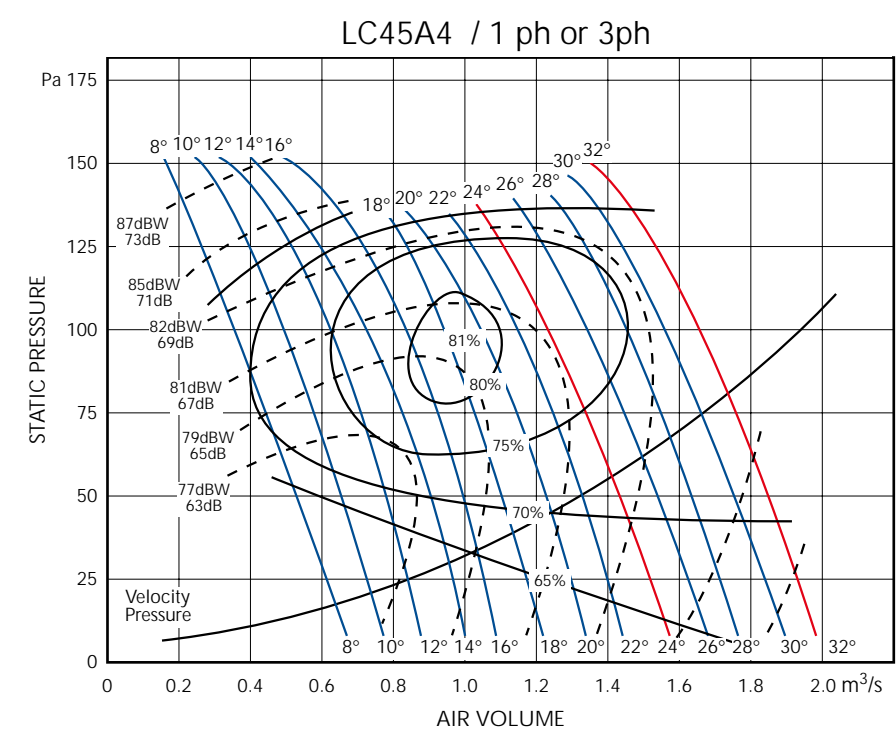

IN DUCT	OCTAVE BAND MID-FREQUENCY Hz (c/s)							
SPECTRUM	63	125	250	500	1000	2000	4000	8000
CONSTANTS	7	5	7	9	10	15	21	23

VENT-AXIA LONG CASE AXIAL FANS PERFORMANCE CURVES

To obtain the sound spectrum in the octave bands 63 to 8000 Hz, subtract the constants shown under each performance chart from the dBW figure on the chart.

LC50A2 / 3ph

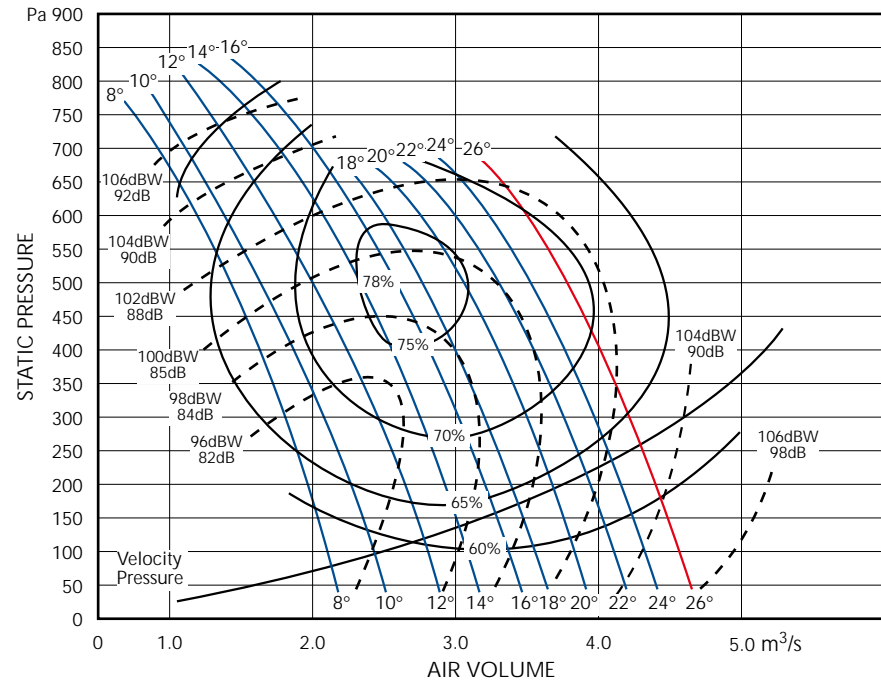

IN DUCT	OCTAVE BAND MID-FREQUENCY Hz (c/s)							
SPECTRUM	63	125	250	500	1000	2000	4000	8000
CONSTANTS	7	8	6	8	10	14	20	24

LC56A2 / 3ph

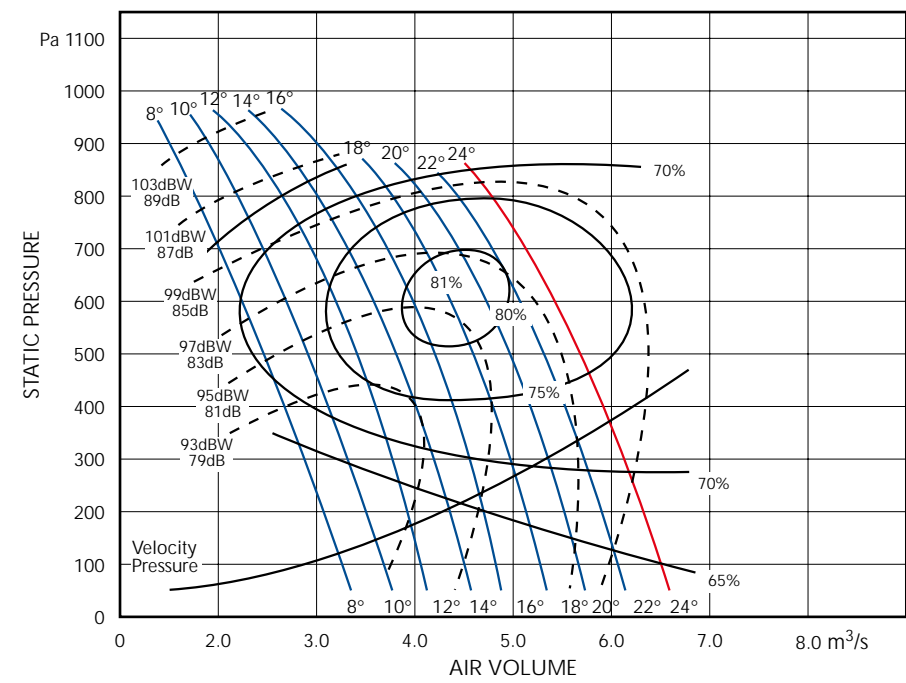

IN DUCT	OCTAVE BAND MID-FREQUENCY Hz (c/s)							
SPECTRUM	63	125	250	500	1000	2000	4000	8000
CONSTANTS	10	10	7	8	11	14	18	23

LC50A4 / 1ph or 3ph

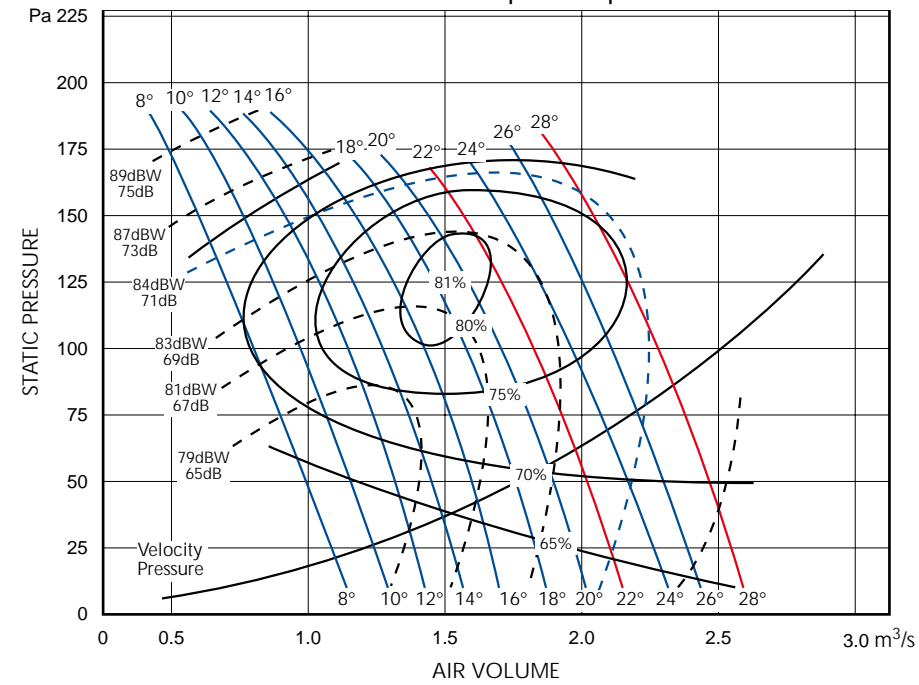

IN DUCT	OCTAVE BAND MID-FREQUENCY Hz (c/s)							
SPECTRUM	63	125	250	500	1000	2000	4000	8000
CONSTANTS	7	5	7	9	10	15	21	23

LC56A4 / 1ph or 3ph

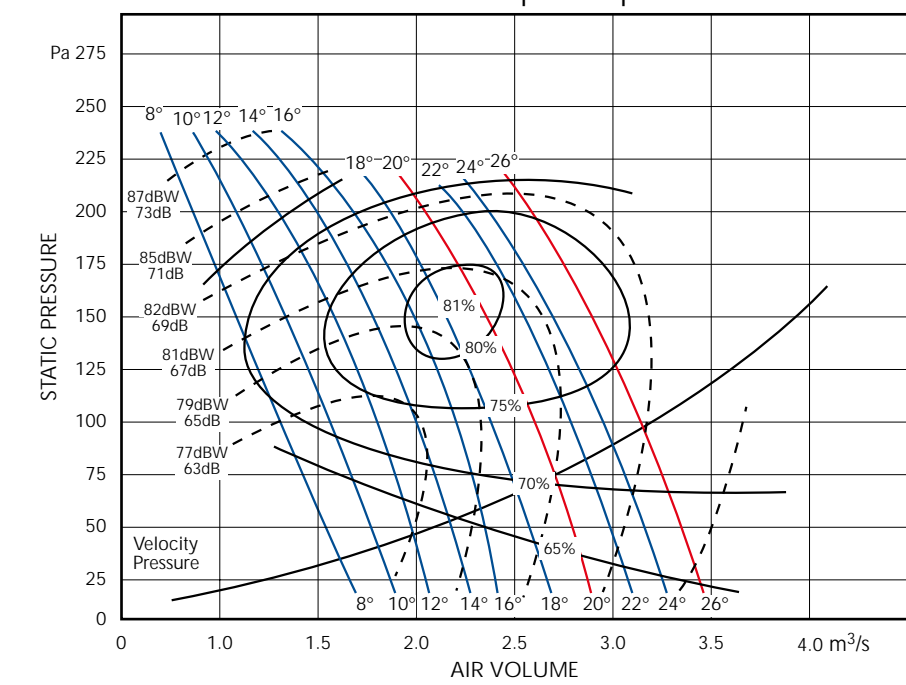

IN DUCT	OCTAVE BAND MID-FREQUENCY Hz (c/s)							
SPECTRUM	63	125	250	500	1000	2000	4000	8000
CONSTANTS	7	5	7	9	10	15	21	27

VENT-AXIA LONG CASE AXIAL FANS PERFORMANCE CURVES

To obtain the sound spectrum in the octave bands 63 to 8000 Hz, subtract the constants shown under each performance chart from the dBW figure on the chart.

LC63A2 / 3ph

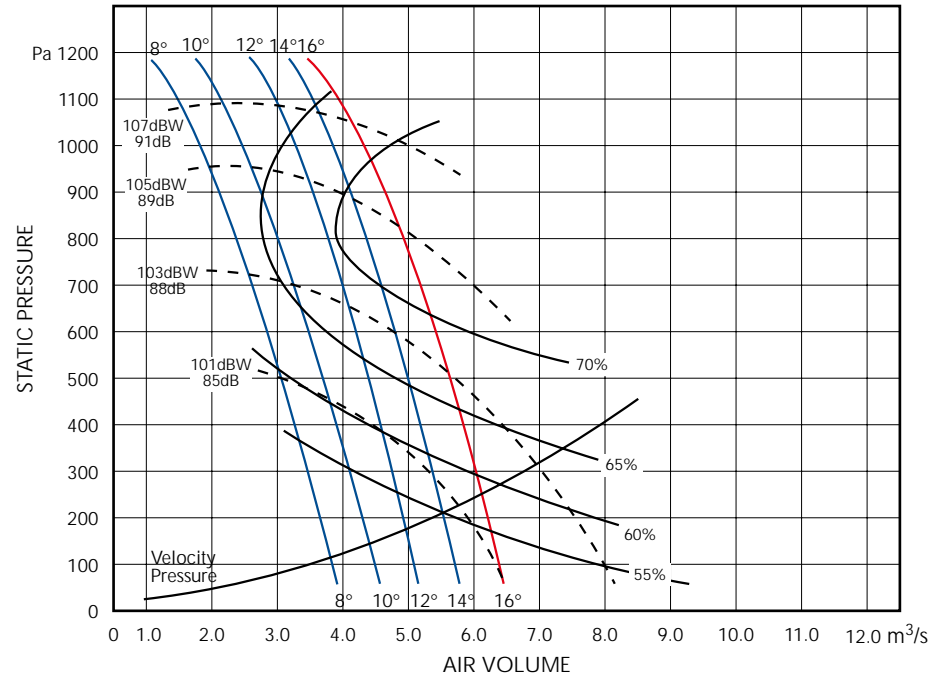

IN DUCT	OCTAVE BAND MID-FREQUENCY Hz (c/s)							
SPECTRUM	63	125	250	500	1000	2000	4000	8000
CONSTANTS	9	10	7	9	10	14	19	26

LC63A4 / 1ph

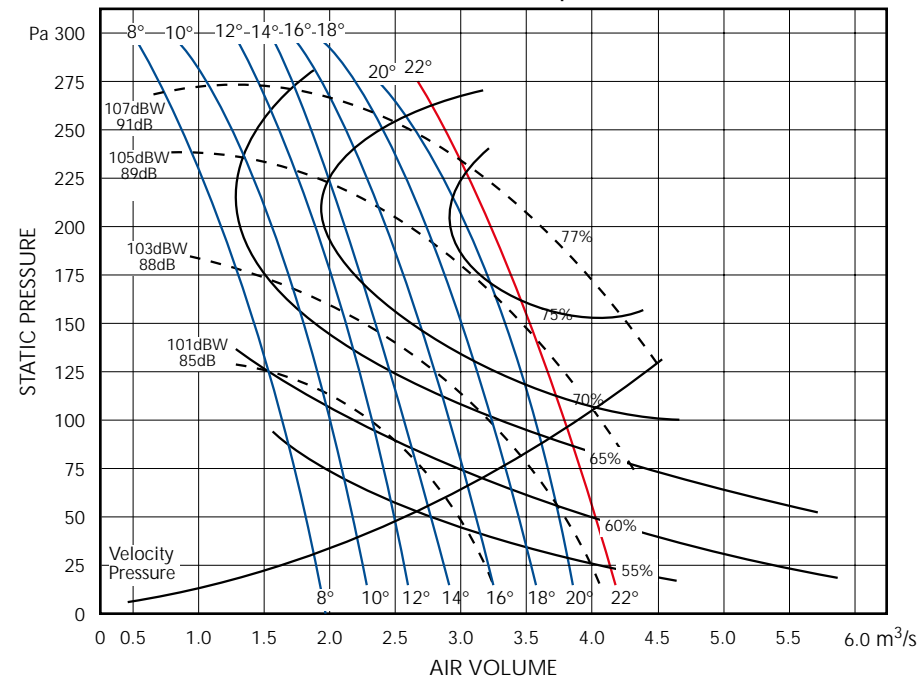

IN DUCT	OCTAVE BAND MID-FREQUENCY Hz (c/s)							
SPECTRUM	63	125	250	500	1000	2000	4000	8000
CONSTANTS	9	10	7	8	11	14	18	21

LONG CASE AXIAL FANS PERFORMANCE CURVES

LC63A4 / 3ph

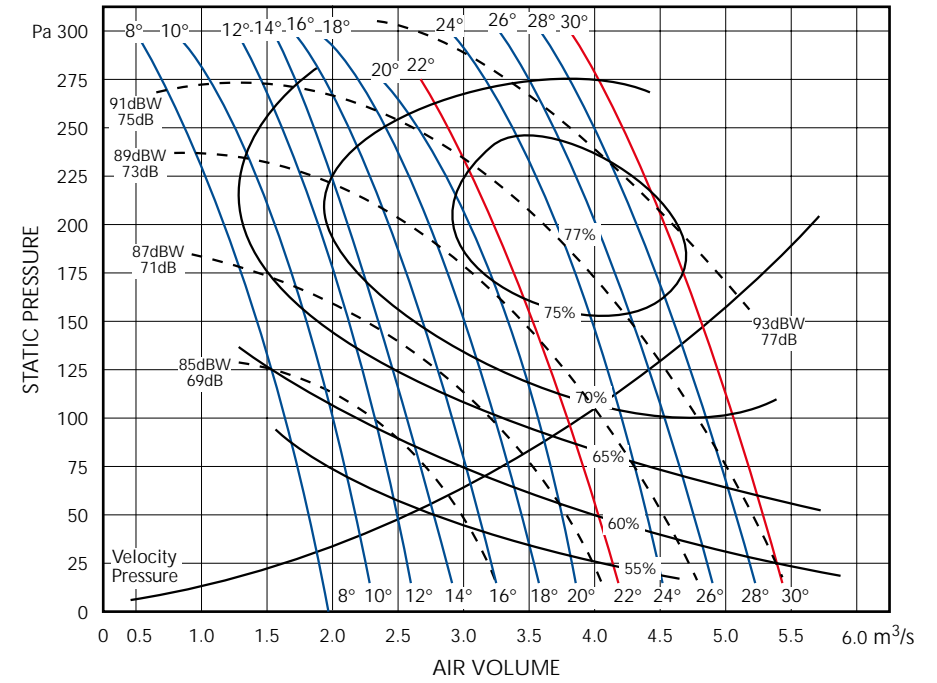

IN DUCT	OCTAVE BAND MID-FREQUENCY Hz (c/s)							
SPECTRUM	63	125	250	500	1000	2000	4000	8000
CONSTANTS	9	10	7	9	10	14	19	26

LC71A4 / 3ph

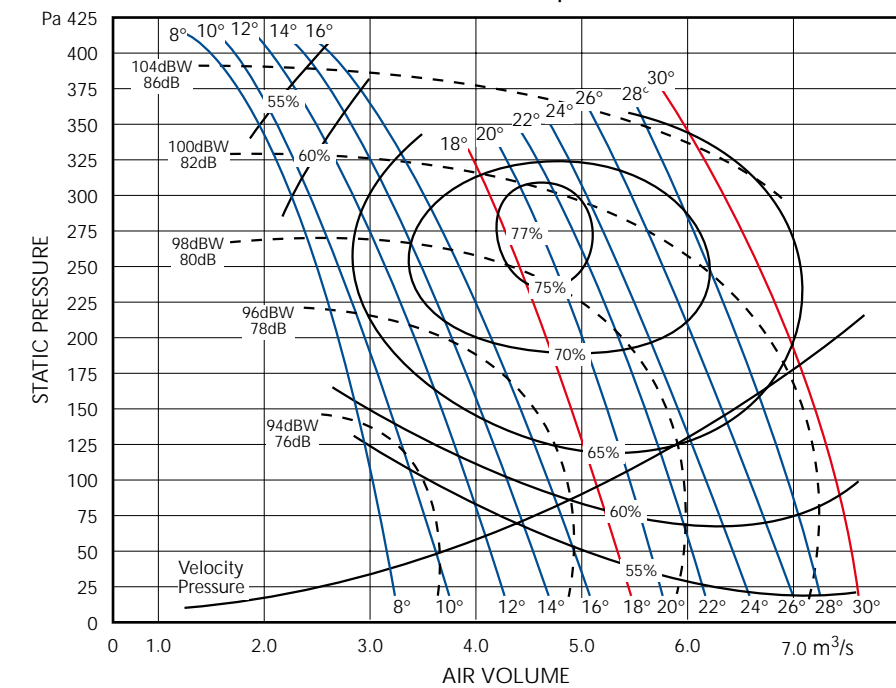

IN DUCT	OCTAVE BAND MID-FREQUENCY Hz (c/s)							
SPECTRUM	63	125	250	500	1000	2000	4000	8000
CONSTANTS	7	10	7	9	10	14	19	25

VENT-AXIA LONG CASE AXIAL FANS PERFORMANCE CURVES

To obtain the sound spectrum in the octave bands 63 to 8000 Hz, subtract the constants shown under each performance chart from the dBW figure on the chart.

LC80A4 / 3ph

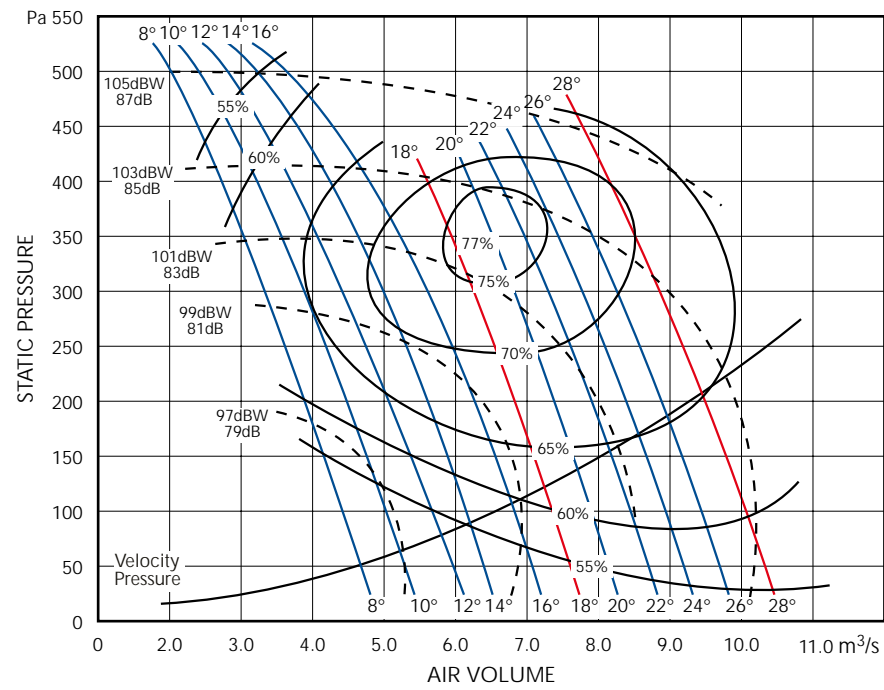

IN DUCT	OCTAVE BAND MID-FREQUENCY Hz (c/s)							
SPECTRUM	63	125	250	500	1000	2000	4000	8000
CONSTANTS	6	14	7	9	10	12	17	24

LC100A4 / 3ph

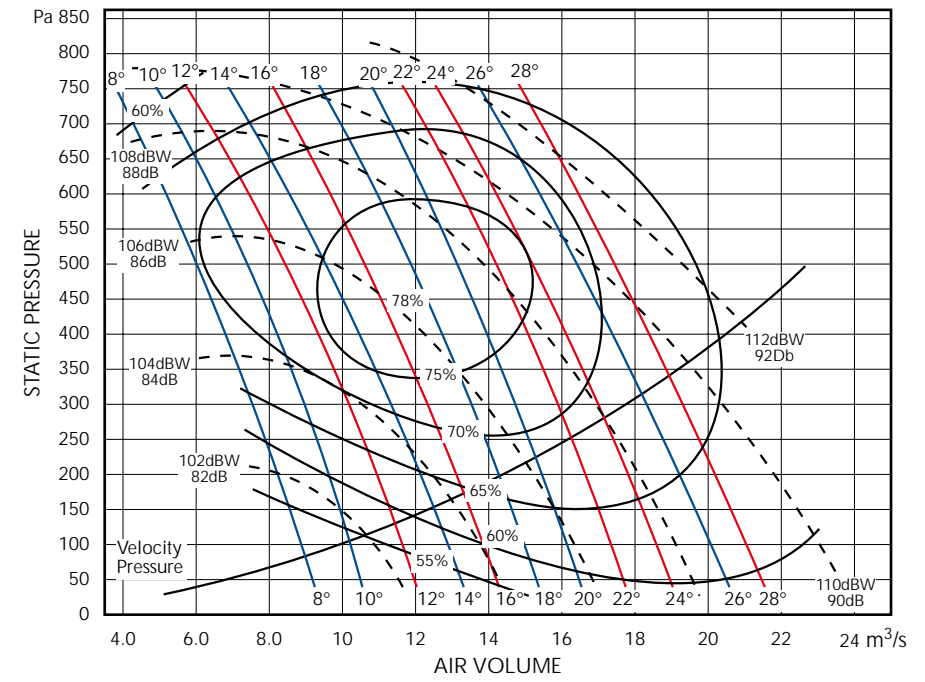

IN DUCT	OCTAVE BAND MID-FREQUENCY Hz (c/s)							
SPECTRUM	63	125	250	500	1000	2000	4000	8000
CONSTANTS	7	14	7	9	10	12	17	24

LC90A4 / 3ph

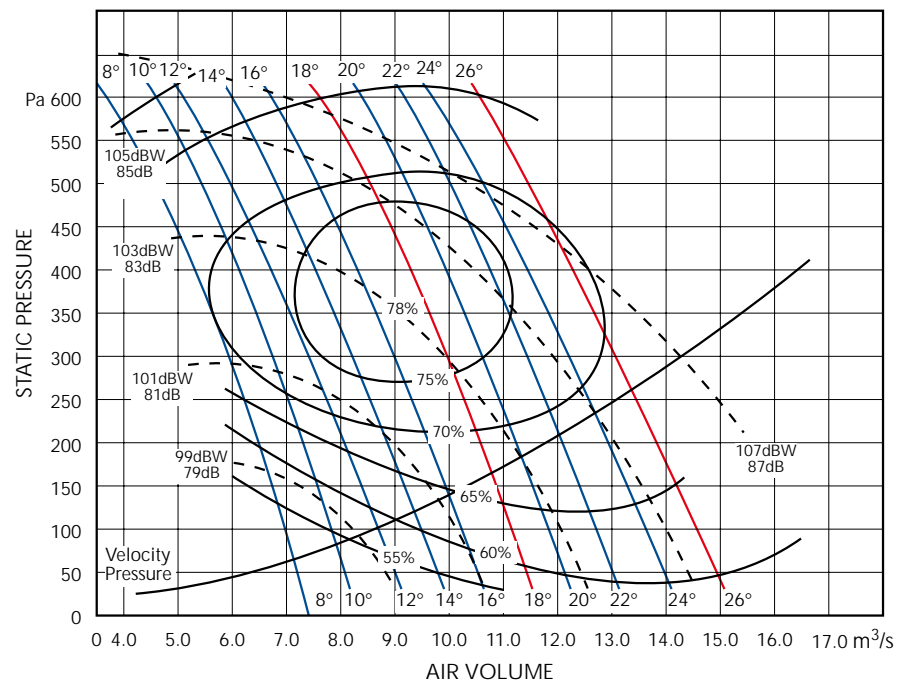

IN DUCT	OCTAVE BAND MID-FREQUENCY Hz (c/s)							
SPECTRUM	63	125	250	500	1000	2000	4000	8000
CONSTANTS	5	10	7	9	10	14	19	24

LC125A4 / 3ph

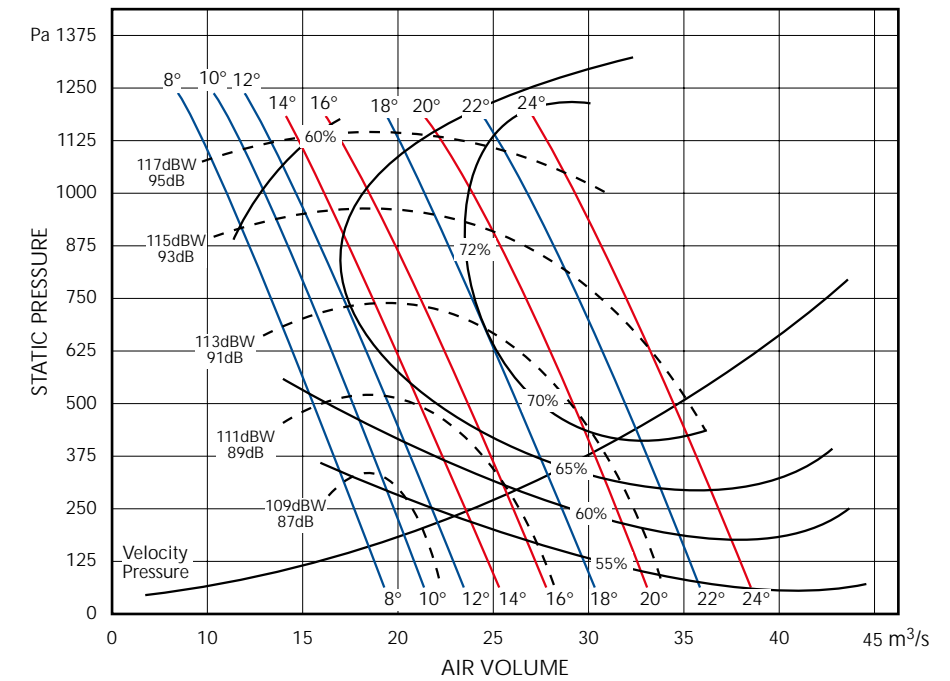

IN DUCT	OCTAVE BAND MID-FREQUENCY Hz (c/s)							
SPECTRUM	63	125	250	500	1000	2000	4000	8000
CONSTANTS	16	14	7	9	10	12	17	21

VENT-AXIA LONG CASE AXIAL FANS ELECTRICAL DETAILS

1 Phase 2 Pole Motors

Stock Ref. No.	Pitch Angle Range	Nominal rpm	Motor kW	Amps F.L.C.	Amps S.C.	Type of Starter	1 Phase Starter 103-11-240 Overload	5 Step Auto-Transformer 1 Phase
LC31A 2/1/22	8 TO 22	2900	0.37	2.65	9.30	D.O.L	103 12 040	N/A
LC31A 2/1/32	24 TO 32	2900	0.55	3.60	11.70	D.O.L	103 12 070	N/A
LC35A 2 /1/22	8 TO 22	2900	0.55	3.60	11.70	D.O.L	103 12 070	N/A
LC35A 2 /1/32	24 TO 32	2900	0.75	5.00	15.00	D.O.L	103 12 070	N/A
LC40A 2 /1/16	8 TO 16	2900	0.75	5.00	15.00	D.O.L	103 12 070	N/A
LC40A 2 /1/28	18 TO 28	2900	1.50	10.90	60.00	D.O.L	103 12 077	N/A

1 Phase 4 Pole Motors

Stock Ref. No.	Pitch Angle Range	Nominal rpm	Motor kW	Amps F.L.C.	Amps S.C.	Type of Starter	1 Phase Starter 103-11-240 Overload	5 Step Auto-Transformer 1 Phase
LC31A 4/1/32	8 TO 32	1440	0.25	1.91	6.70	D.O.L	103 12 027	103-14-103
LC35A 4/1/32	8 TO 32	1440	0.25	1.91	6.70	D.O.L	103 12 027	103-14-103
LC40A 4/1/32	8 TO 32	1440	0.25	1.91	6.70	D.O.L	103 12 027	103-14-103
LC45A 4/1/24	8 TO 24	1440	0.37	2.80	9.00	D.O.L	103 12 040	103-14-103
LC45A 4/1/32	26 TO 32	1440	0.55	3.90	13.65	D.O.L	103 12 070	103-14-105
LC50A 4/1/22	8 TO 22	1440	0.55	3.90	13.65	D.O.L	103 12 070	103-14-105
LC50A 4/1/28	24 TO 28	1440	0.75	5.20	20.80	D.O.L	103 12 070	103-14-107
LC56A 4/1/20	8 TO 20	1440	0.75	5.20	20.80	D.O.L	103 12 070	103-14-107
LC56A 4/1/26	22 TO 26	1440	1.10	6.90	24.15	D.O.L	103 12 105	103-14-107
LC63A 4/1/22	8 TO 22	1440	1.50	10.20	37.70	D.O.L	103 12 077	103-14-113

3 Phase 2 Pole Motors

Stock Ref. No.	Pitch Angle Range	Nominal rpm	Motor kW	Amps F.L.C.	Amps S.C.	Type of Starter	3 Phase Starter 103-11-240 Coil Starter 103-11-415 Coil Overload	5 Step Auto-Transformer 3 Phase
LC31A 2/3/22	8 TO 22	2900	0.37	0.92	5.06	D.O.L	103 12 018	N/A*
LC31A 2/3/32	24 TO 32	2900	0.55	1.27	6.35	D.O.L	103 12 018	N/A*
LC35A 2 /3/22	8 TO 22	2900	0.55	1.27	6.35	D.O.L	103 12 018	N/A*
LC35A 2/3/32	24 TO 32	2900	0.75	1.81	9.50	D.O.L	103 12 027	N/A*
LC40A 2/3/16	8 TO 16	2900	0.75	1.81	9.50	D.O.L	103 12 027	N/A*
LC40A 2/3/28	18 TO 28	2900	1.50	3.20	19.20	D.O.L	103 12 040	N/A*
LC45A 2/3/24	8 TO 24	2900	3.00	5.85	40.95	D.O.L	106 12 070	N/A*
LC50A 2/3/16	8 TO 16	2900	3.00	5.85	40.95	D.O.L	103 12 070	N/A*

3 Phase 2 Pole Motors

Stock Ref. No.	Pitch Angle Range	Nominal rpm	Motor kW	Amps F.L.C.	Amps S.C.	Type of Starter	3 Phase Starter 103-15-415 Coil Overload	5 Step Auto-Transformer 3 Phase
LC50A 2/3/26	18 TO 26	2900	5.50	10.80	70.20	Star Delta	103 12 105	N/A*
LC56A 2/3/18	8 TO 18	2900	5.50	10.80	70.20	Star Delta	103 12 105	N/A*
LC56A 2/3/24	20 TO 24	2900	7.50	14.40	100.80	Star Delta	103 12 105	N/A*
LC63A 2/3/16	8 TO 16	2900	7.50	14.40	100.80	Star Delta	103 12 105	N/A*

*See page 83 for Inverter Controller details

LONG CASE AXIAL FANS ELECTRICAL DETAILS

3 Phase 4 Pole Motors

Stock Ref. No.	Pitch Angle Range	Nominal rpm	Motor kW	Amps F.L.C.	Amps S.C.	Type of Starter	3 Phase Starter 103-11-240 Coil Starter 103-11-415 Coil Overload	5 Step Auto-Transformer 3 Phase
LC31A 4/3/32	8 TO 32	1440	0.25	0.65	2.60	D.O.L	103 12 011	103 14 301
LC35A 4/3/32	8 TO 32	1440	0.25	0.65	2.60	D.O.L	103 12 011	103 14 301
LC40A 4/3/32	8 TO 32	1440	0.25	0.65	2.60	D.O.L	103 12 011	103 14 301
LC45A 4/3/24	8 TO 24	1440	0.37	1.13	4.52	D.O.L	103 12 018	103 14 301
LC45A 4/3/32	26 TO 32	1440	0.55	1.51	6.80	D.O.L	103 12 018	103 14 304
LC50A 4/3/22	8 TO 22	1440	0.55	1.51	6.80	D.O.L	103 12 018	103 14 304
LC50A 4/3/28	24 TO 28	1440	0.75	1.98	9.90	D.O.L	103 12 027	103 14 304
LC56A 4/3/20	8 TO 20	1440	0.75	1.98	9.90	D.O.L	103 12 027	103 14 304
LC56A 4/3/26	22 TO 26	1440	1.10	2.60	14.30	D.O.L	103 12 040	103 14 304
LC63A 4/3/22	8 TO 22	1440	1.50	3.60	19.80	D.O.L	103 12 070	103 14 304
LC63A 4/3/30	24 TO 30	1440	3.00	6.50	40.10	D.O.L	103 12 105	103 14 307
LC71A 4/3/18	8 TO 18	1440	2.20	4.90	29.40	D.O.L	103 12 070	103 14 307

3 Phase 4 Pole Motors

Stock Ref. No.	Pitch Angle Range	Nominal rpm	Motor kW	Amps F.L.C.	Amps S.C.	Type of Starter	3 Phase Starter 103-15-415 Coil Overload	5 Step Auto-Transformer 3 Phase
LC71A 4/3/30	20 TO 30	1440	4.00	8.50	57.40	Star Delta	103 12 070	N/A*
LC80A 4/3/18	8 TO 18	1440	4.00	8.50	57.40	Star Delta	103 12 070	N/A*
LC80A 4/3/28	20 TO 28	1440	7.50	15.20	112.50	Star Delta	103 12 105	N/A*
LC90A 4/3/10	8 TO 10	1440	5.50	11.50	77.10	Star Delta	103 12 105	N/A*
LC90A 4/3/18	12 TO 18	1440	7.50	15.20	112.50	Star Delta	103 12 105	N/A*
LC90A 4/3/26	20 TO 26	1440	11.00	22.40	134.40	Star Delta	103 12 077	N/A*
LC100A 4/3/12	8 TO 12	1440	7.50	15.20	112.50	Star Delta	103 12 105	N/A*
LC100A 4/3/16	14 TO 16	1440	11.00	22.40	134.40	Star Delta	103 12 077	N/A*
LC100A 4/3/22	18 TO 22	1440	15.00	29.70	193.00	Star Delta	103 12 039	N/A*
LC100A 4/3/24	24	1440	18.50	36.00	234.00	Star Delta	103 12 055	N/A*
LC100A 4/3/28	26 TO 28	1440	22.00	42.50	287.00	Star Delta	103 12 055	N/A*

3 Phase 4 Pole Motors

Stock Ref. No.	Pitch Angle Range	Nominal rpm	Motor kW	Amps F.L.C.	Amps S.C.	Type of Starter	3 Phase Star/Delta Starter	5 Step Auto-Transformer 3 Phase
LC125A 4/3/14	8 TO 14	1440	30.00	59.50	446.00	Star Delta	45 50 08	N/A*
LC125A 4/3/16	16	1440	37.00	70.50	458.00	Star Delta	45 50 09	N/A*
LC125A 4/3/20	18 TO 20	1440	45.00	85.50	556.00	Star Delta	45 50 10	N/A*
LC125A 4/3/24	22 TO 24	1440	55.00	105.00	735.00	Star Delta	45 50 11	N/A*

SPEED CONTROLLER

Used in conjunction with speed controllable fans Vent-Axia offers a choice of speed controllers, the traditional Five-Step Auto Transformer or the Inverter Speed Controller.

The **Five-Step-Auto Transformer** provides five stepped speed settings without the electronic motor harmonic noise associated with all electronic or solid state type Speed Controllers.

The **Inverter Speed Controller** offers a more flexible solution to speed control and is infinitely variable. The inverter controller package, comprises of the inverter controller, a built in or separate filter where applicable and separate Inverter Low Voltage Controller. The Inverter Controller is installed adjacent to the fan. The Low Voltage Controller can then be installed up to a distance of 50m away from the Inverter Controller and is wired using 5 core low voltage wire. This controller has a rotary speed control and separate On/Off switch. The Inverter Controller package is factory matched to the individual fan for ease of installation.

*See page 83 for Inverter Controller details

VENT-AXIA LONG CASE AXIAL FANS DIMENSIONS (mm)

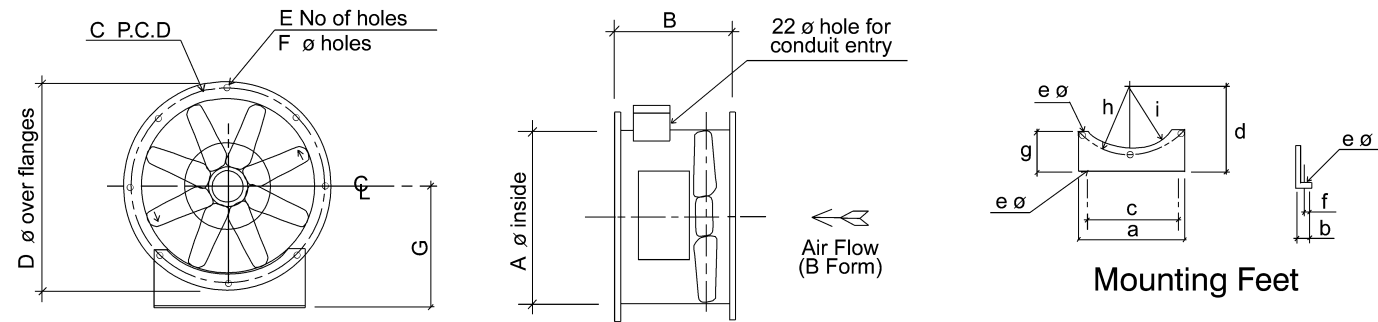

No.	A	B	C	D	E	F	G	a	b	c	d	e	f	g	h	i
LC31 A2/1&3/ 8-32	315	420	355	385	8	10	224	275	24	224	224	10	14	115	177.5	167
LC31 A4/1&3/ 8-32	315	420	355	385	8	10	224	275	24	224	224	10	14	115	177.5	167
LC35 A2/1&3/ 8-32	355	420	395	425	8	10	250	303	24	250	250	10	14	125	197.5	187
LC35 A4/1&3/ 8-32	355	420	395	425	8	10	250	303	24	250	250	10	14	125	197.5	187
LC40 A2/1&3/ 8-28	400	435	450	480	8	12	280	348	24	280	280	12	14	135	225	213
LC40 A4/1&3/ 8-32	400	435	450	480	8	12	280	348	24	280	280	12	14	135	225	213
LC45 A2/3/ 8-24	450	435	500	530	8	12	315	384	24	315	315	12	14	155	250	238
LC45 A4/1&3/ 8-32	450	435	500	530	8	12	315	384	24	315	315	12	14	155	250	238
LC50 A2/3/ 8-16	500	470	560	590	12	12	315	425	24	315	315	12	14	135	280	268
LC50 A2/3/ 18-26	500	565	560	590	12	12	315	425	24	315	315	12	14	135	280	268
LC50 A4/1&3/ 8-28	500	470	560	590	12	12	315	425	24	315	315	12	14	135	280	268
LC56 A2/3/ 8-18	560	470	620	650	12	12	355	475	24	355	355	12	14	155	310	298
LC56 A2/3/ 20-24	560	565	620	650	12	12	355	475	24	355	355	12	14	155	310	298
LC56 A4/1&3/ 8-26	560	470	620	650	12	12	355	475	24	355	355	12	14	155	310	298
LC63 A2/3/ 8-16	630	565	690	720	12	12	400	520	24	400	400	12	14	175	345	333
LC63 A4/1/ 8-22	630	470	690	720	12	12	400	520	24	400	400	12	14	175	345	333
LC63 A4/3/ 8-30	630	470	690	720	12	12	400	520	24	400	400	12	14	175	345	333
LC71A4/3/ 8-30	710	470	770	800	16	12	410	710	40	610	435	13	18	240	385	365
LC80 A4/3/ 8-18	800	470	860	890	16	12	450	800	40	700	480	13	18	262	430	410
LC80 A4/3/ 20-28	800	565	860	890	16	12	450	800	40	700	480	13	18	262	430	410
LC90 A4/3/ 8-18	900	565	970	1038	16	14	500	900	40	800	535	13	18	288	485	460
LC90 A4/3/ 20-26	900	700	970	1038	16	14	500	900	40	800	535	13	18	288	485	460
LC100 A4/3/ 8-12	1000	565	1070	1138	16	14	555	1000	40	900	85	15	18	314	535	510
LC100 A4/3/ 14-22	1000	700	1070	1138	16	14	555	1000	40	900	585	15	18	314	535	510
LC100 A4/3/ 24-28	1000	790	1070	1138	16	14	555	1000	40	900	585	15	18	314	535	510
LC125 A4/3/ 8-14	1250	950	1320	1390	20	15	868	1250	80	1150	868	15	26	366	660	640
LC125 A4/3/ 16-24	1250	1100	1320	1390	20	15	868	1250	80	1150	868	15	26	366	660	640

LONG CASE AXIAL FANS ACCESSORIES DIMENSIONS

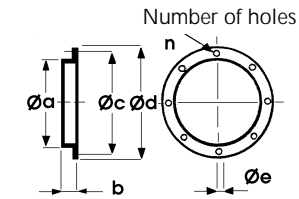

COUPLING FLANGE

Rolled from mild steel. Dimensionally matched to fan flange and fixing holes

Stock Ref. No.	overall a	spigot b	pcd c	int dia d	hole dia e	No. holes
105 06 315	385	30	355	315	10	8
105 06 355	425	45	395	355	10	8
105 06 400	480	45	450	400	12	8
105 06 450	530	60	500	450	12	8
105 06 500	590	0	560	500	12	12
105 06 560	650	75	620	560	12	12
105 06 630	720	75	690	630	12	12
105 06 710A	794	40	770	710	12	13
105 06 800A	884	40	860	800	12	13
105 06 900A	1100	50	970	900	14	15
105 06 1000A	1100	50	1070	1000	14	15
105 06 1250A	1380	83	1320	1250	15	20

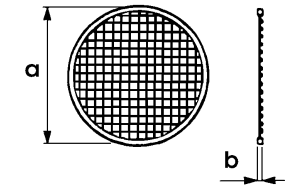

INLET WIRE GUARD

'K' factor loss 0.25

Available for direct fixing to either side of the fan using flange sizing holes. Constructed to meet BS 848 Part 5

Stock Ref. No.	a	b
105 05 315	380	3
105 05 355	420	3
105 05 400	475	3
105 05 450	525	3
105 05 500	595	3
105 05 560	655	3
105 05 630	725	3
105 05 710	784	10
105 05 800	870	10
105 05 900	970	10
105 05 1000	1090	10
105 05 1250	1370	10

ANTI-VIBRATION MOUNTS

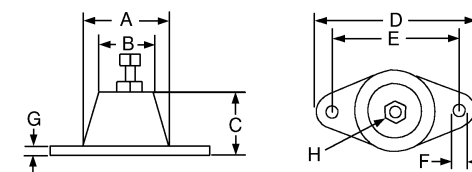

Stock Ref. No.	A	B	C	D	E	F	G	H	Max. Load kg
105 23 033	37	26	27	67	54	7	3	M8	23
105 23 055	37	26	27	67	54	7	3	M8	36
105 23 133	57	46	35	95	76	10.5	4	M12	91
105 23 165	57	46	35	95	76	10.5	4	M12	245

WEIGHTS

Stock Ref. No.	Weight Kg
LC31A2/1/22	23
LC31A2/3/22	23
LC31A2/1/32	23
LC31A2/ 3/32	23
LC35A2/1/22	25
LC35A2/ 3/22	25
LC35A2/1/32	29
LC35A2/ 3/32	29
LC40A2/1/16	33
LC40A2/3/16	33
LC40A2/1/28	38
LC40A2/3/28	38
LC45A2/3/24	49
LC50A2/3 /16	56
LC50A2/3/26	86
LC56A2/3/18	60
LC56A2/3/24	94
LC63A2/3/16	96

Stock Ref. No.	Weight Kg
LC31A4/1/32	23
LC31A4/3/32	23
LC35 A4/1/32	25
LC35A4/3/32	25
LC40A4/1/32	29
LC40A4/3/32	29
LC45A4/1/24	32
LC45A4/3/24	32
LC45A4/1/32	36
LC45A4/3/32	36
LC50A4/1/22	43
LC50A4/3/22	43
LC50A4/1/28	43
LC50A4/3/28	43
LC56A4/1/20	51
LC56A4/3/20	47
LC56A4/1/26	52
LC56 A4/3/26	52

Stock Ref. No.	Weight Kg
LC63A4/1/22	54
LC63A4/3/22	54
LC63A4/3/30	62
LC71A4/3/18	83
LC71A4/3/30	92
LC80 A4/3/18	103
LC80 A4/3/28	131
LC90A4/3/14	150
LC90A4/3/18	150
LC90 A4/3/26	214
LC100A4/3/12	161
LC100A4/3/16	228
LC100A4/3/22	228
LC100A4/3/24	274
LC100A4/3/28	274
LC125A4/3/14	708
LC125A4/3/16	793
LC125A4/3/20	848
LC125A4/3/24	903

VENT-AXIA LONG CASE AXIAL FANS ACCESSORIES

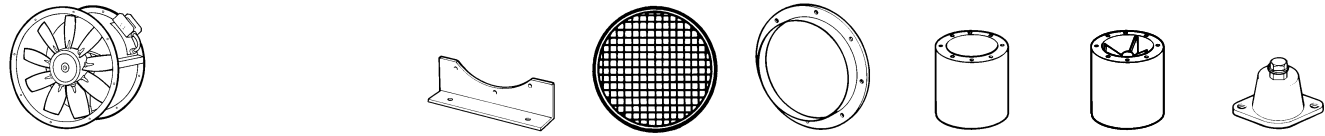

Stock Ref. No.	Pitch Angle Range Stock Ref. No.	Ancillary Pack Stock Ref. No.	Mounting Feet Stock Ref. No.	Inlet Wire Guard Stock Ref. No.	Coupling Flange Stock Ref. No.	Case Axial Attenuator Stock Ref. No.	Axial Attenuator inc. Pod Stock Ref. No.	Anti-Vibration Mount Stock Ref. No.
LC31A2/1 LC31A4/1&3	/8-32 /8-32	105 13 315	105 03 315	105 05 315	105 06 315	105 14 315	105 00 315	105 23 003
LC35A2/1 LC35A4/1&3	/8-32 /8-32	105 13 355	105 03 355	105 05 355	105 06 355	105 14 355	105 00 355	105 23 003
LC40A2/1 LC40A4/1&3	/8-28 /8-32	105 13 400	105 03 400	105 05 400	105 06 400	105 14 400	105 00 400	105 23 003
LC45A2/3 LC45A4/1&3 LC45A4/1&3	/8-24 /8-24 /26-32	105 13 450	105 03 450	105 05 450	105 06 450	105 14 450	105 00 450	105 23 003
LC50A2/3 LC50A2/3 LC50A4/1&3	/8-16 /18-26 /8-28	105 13 500	105 03 500	105 05 500	105 06 500	105 14 500	105 00 500	105 23 003 105 23 055 105 23 003
LC56A2/3 LC56A4/1&3	/8-24 /8-26	105 13 560	105 03 560	105 05 560	105 06 560	105 14 560	105 00 560	105 23 055 105 23 003
LC63A2/3 LC63A2/1&3 LC63A4/3	/8-16 /8-22 /24-30	105 13 630	105 03 630	105 05 630	105 06 630	105 14 630	105 00 630	105 23 055 105 23 003 105 23 003
LC71A4/3	/8-30	105 13 710A	105 03 710A	105 05 710A	105 06 710A	105 14 710A	105 00 710	105 23 055
LC80A4/3	/8-28	105 13 800A	105 03 800A	105 05 800A	105 06 800A	105 14 800A	105 00 800	105 23 055
LC90A4/3	/8-26	105 13 900A	105 03 900A	105 05 900A	105 06 900A	105 14 900A	105 00 900	105 23 133
LC100A4/3	/8-28	105 13 1000A	105 03 1000A	105 05 1000A	105 06 1000A	105 14 1000A	105 00 1000	105 23 133
LC125A4/3	/8-24	105 13 1250A	105 03 1250A	105 05 1250A	105 06 1250A	105 14 1250A	105 00 1250	105 23 165

AXIAL ANCILLARY PACK

consists of:

- 2 Matching flanges
- 2 Flexible connectors
- 2 Mounting feet
- 4 Anti vibration mounts
- 4 Worm drive clips

IMPERIAL ACCESSORIES SIZES 315, 400, 500, 630

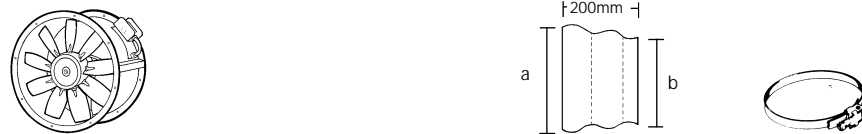

Model	a Metric Size Accessories	b Imperial Size Accessories	Imperial Flexible Connector Stock Ref. No.	Worm Drive Clips Stock Ref. No
LC 315	315	12"	105 06 012	*56 17 15
LC 400	400	15"	105 06 015	*56 17 15
LC 500	500	19"	105 06 019	57 17 20
LC 630	630	24"	105 06 024	*57 17 26

* Two clips are required per Flexible Connector

LONG CASE AXIAL FANS INVERTER DETAILS



2 POLE Stock Ref. No.	Pitch Angle Range	Single Phase Supply	Three Phase Supply
LC31 A2 /3/22	8 TO 22	103 20 101 01	103 20 301 01
LC31 A2 /3/32	24 TO 32	103 20 101 02	103 20 301 02
LC35 A2 /3/22	8 TO 22	103 20 101 02	103 20 301 02
LC35 A2 /3/32	24 TO 32	103 20 101 03	103 20 301 03
LC40 A2 /3/16	8 TO 16	103 20 101 03	103 20 301 03
LC40 A2 /3/28	18 TO 28	103 20 102 01	103 20 302 01
LC45 A2 /3/24	8 TO 24	N/A	103 20 305 01
LC50 A2 /3/16	8 TO 16	N/A	103 20 305 01
LC50 A2 /3/26	18 TO 26	N/A	103 20 350 01
LC56 A2 /3/18	8 TO 18	N/A	103 20 350 01
LC56 A2 /3/24	20 TO 24	N/A	103 20 310 01
LC63 A2 /3/16	8 TO 16	N/A	103 20 310 01

4 POLE Stock Ref. No.	Pitch Angle Range	Single Phase Supply	Three Phase Supply
LC31 A4/3/32	8 TO 32	103 20 101 04	103 20 301 04
LC35 A4/3/32	8 TO 32	103 20 101 04	103 20 301 04
LC40 A4/3/32	8 TO 32	103 20 101 04	103 20 301 04
LC45 A4/3/24	8 TO 24	103 20 101 05	103 20 301 05
LC45 A4/3/32	26 TO 32	103 20 101 06	103 20 301 06
LC50 A4/3/22	8 TO 32	103 20 101 06	103 20 301 06
LC50 A4/3/28	24 TO 28	103 20 101 07	103 20 301 07
LC56 A4/3/20	8 TO 20	103 20 101 07	103 20 301 07
LC56 A4/3/26	22 TO 26	103 20 102 02	103 20 302 08
LC63 A4/3/2	8 TO 22	103 20 102 03	103 20 302 02
LC63 A4/3/30	24 TO 30	N/A	103 20 305 02
LC71 A4/3/18	8 TO 18	103 20 103 01	103 20 305 03
LC71 A4/3/30	20 TO 30	N/A	103 20 350 02
LC80 A4/3/18	8 TO 18	N/A	103 20 350 02
LC80 A4/3/28	20 TO 28	N/A	103 20 310 02
LC90 A4/3/10	8 TO 10	N/A	103 20 310 03
LC90 A4/3/18	12 TO 18	N/A	103 20 310 04
LC90 A4/3/26	20 TO 26	N/A	103 20 315 01
LC100 A4/3/12	8 TO 12	N/A	103 20 315 02
LC100 A4/3/16	14 TO 16	N/A	103 20 315 01
LC100 A4/3/22	18 TO 22	N/A	103 20 320 01
LC100 A4/3/24	24	N/A	103 20 325 01
LC100 A4/3/28	26 TO 28	N/A	103 20 330 01
LC125 A4/3/14	8 TO 14	N/A	103 20 340 01
LC125 A4/3/16	16	N/A	103 20 350 01
LC125 A4/3/20	18 TO 20	N/A	103 20 360 01
LC125 A4/3/24	22 TO 24	N/A	103 20 375 01

INVERTER CONTROLLERS

Inverter (Variable speed drives) are suitable for all models of inverter controllable three phase fans. Offering complete user adaptability Vent-Axia Inverters offer the following benefits: -

Frequency control setting resolution from 0-100% in 0.1 increments (not only providing total speed control, but also enabling energy savings to be made through the fine tuning/optimisation of the fan)

Pre-settable minimum/maximum speed. Overload protection – 150% for 1 minute, therefore protecting the fan from drawing excessive current.

Stall prevention during acceleration, deceleration and constant speed, preventing nuisance tripping and problems.

The versatility of the Inverter means that a single drive unit can be used to control the speed of multiple fans, provided that their combined loads do not exceed the drive capacity.

Using an Inverter is by far the most effective and efficient way of controlling and optimising your fan or fans.

The Inverter Speed Controller Kit will include either a built in or separate EMC filter, a ferrite coil and a low voltage variable speed controller. The controls set will be matched to each individual fan and factory set, this will eliminate the need for any programming of the inverter controller on site.

VENT-AXIA LONG CASE AXIAL FANS ATTENUATOR DETAILS

ATTENUATOR INSERTION LOSS DATA

Diameter	Stock Ref. No.	63	125	250	500	1k	2k	4k	8k	kg approx
315	105 14 315	2	3	6	11	16	11	10	6	22
355	105 14 355	2	3	6	12	16	11	10	6	30
400	105 14 400	2	3	6	13	16	12	10	6	41
450	105 14 450	2	4	6	14	17	12	10	6	50
500	105 14 500	3	4	7	14	17	14	11	7	59
560	105 14 560	2	4	8	15	18	14	11	7	70
630	105 14 630	3	4	8	16	18	14	11	7	82
710	105 14 710A	1	2	6	9	12	10	6	2	90
800	105 14 800A	1	2	6	9	12	10	6	2	100
900	105 14 900A	1	2	6	9	12	10	6	2	145
1000	105 14 000A	1	2	6	9	12	10	6	2	184
1250	105 14 1250A	1	2	6	9	12	10	6	2	150

CASED AXIAL ATTENUATOR FITTED WITH POD INSERTION LOSSES

Diameter	Stock Ref. No.	63	125	250	500	1k	2k	4k	8k	kg approx + POD
315	105 00 315	6	7	12	18	27	25	22	19	32
355	105 00 355	3	8	12	18	28	26	22	19	44
400	105 00 400	3	8	12	18	28	26	23	19	60
450	105 00 450	4	8	14	20	28	26	23	19	73
500	105 00 500	4	8	14	20	29	26	23	19	87
560	105 00 560	4	9	14	20	29	26	23	19	102
630	105 00 630	4	9	14	20	29	26	23	19	120
710	105 00 710A	6	10	20	30	35	28	25	22	134
800	105 00 800A	6	10	20	30	35	28	25	22	149
900	105 00 900A	6	10	20	30	35	28	25	22	211
1000	105 00 1000A	6	10	20	30	35	28	25	22	267
1250	105 00 1250A	6	10	17	28	27	21	18	17	222

TYPICAL INSTALLATION

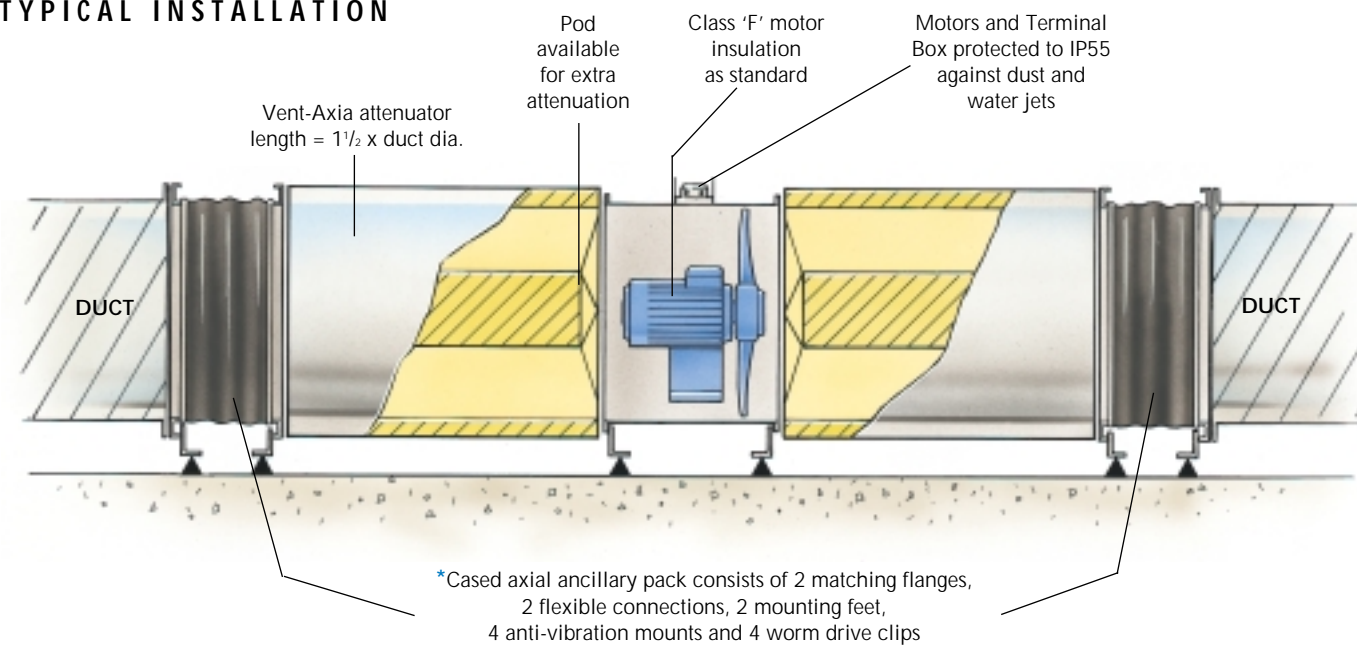

LONG CASE AXIAL FANS ATTENUATOR DETAILS

An attenuator without pod offers negligible resistance to air flow, and therefore the pressure loss can be considered to be the same as that for the equivalent length of ducting.

RESISTANCE GRAPH FOR AXIAL ATTENUATOR WITH POD

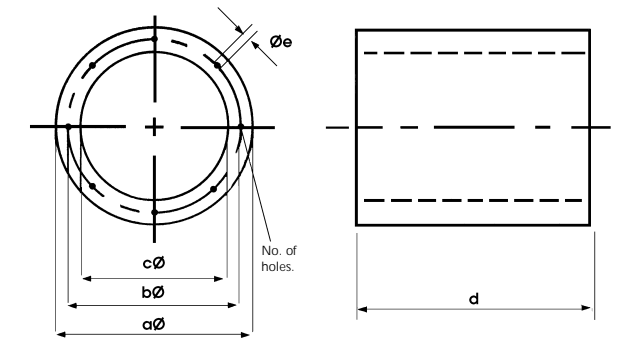
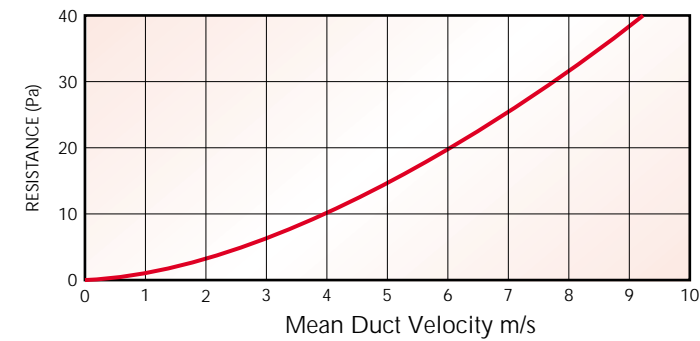

Fan Stock Ref. Code	Stock Ref. No.	Dia a	Dia b	Dia c	Length d	Dia e	No. holes
LC31	105 14 315	415	355	315	475	M8	8
LC35	105 14 355	455	395	355	540	M8	8
LC40	105 14 400	500	450	400	600	M10	8
LC45	105 14 450	550	500	450	675	M10	8
LC50	105 14 500	600	560	500	750	M10	12
LC56	105 14 560	660	620	560	810	M10	12
LC63	105 14 630	730	690	630	940	M10	12
LC71	105 14 710A	814	700	710	1070	M10	16
LC80	105 14 800A	900	860	796	1200	M10	16
LC90	105 14 900A	999	970	893	1350	M10	16
LC100	105 14 1000A	1108	1070	1070	1500	M10	16
LC125	105 14 1250A	1350	1320	1250	1875	M10	16

Melindex lined attenuators are available on request