

Ventilation Accessories



PVC Coated Glass Fibre Flexible Ducting

Lightweight, easily installed ducting. PVC coated glass fibre fabric on a PVC coated steel wire helix. The helix is stronger than similar types available to resist distortion damage due to rough handling.

Fire rating: when assessed against the integrity criterion of **BS 476: Part 20: 1987**, the ducting provides **54 minutes** integrity from inside to outside.

Suitable for applications covered by **BS 5588: Part 9: 1989**, code of practice.

Standard length 3 and 6 metres.

NB: For maximum fan performance it is important that flexible ductwork is fully extended and is adequately supported to eliminate unnecessary bends. Intended bends should be of the largest possible radius.

Unit size	Duct Dia.	Vent-Axia flexible ducting	
		Stock Ref. No. 3 metre length	Stock Ref. No. 6 metre length
Size 6	100 mm	56 36 04	56 66 04
	175 mm	56 36 07	56 66 07
Size 6/7	225 mm	56 36 09	56 66 09
	225 mm	56 36 09	56 66 09
Size 7	250 mm	56 36 10	56 66 10
	300 mm	56 36 12	56 66 12
Size 12	400 mm	56 36 16	56 66 16



Aluminium Flexible Ducting

Lightweight, easy to install ducting made of 5 layer aluminium foil/ polyester on a steel wire helix. The strength of the helix resists distortion and damage due to rough handling.

Fire Rating: When assessed against the integrity criterion of **BS476: Part 20; 1987**, the ducting is capable of providing in excess of **39 minutes** integrity from inside to outside. Available in 100, 125, 150m 200, 250, 315 and 400mm diameter sizes to fit spigot sizes on all modular components in the Airtrak range, (except ACP300).

Standard length: 10 metres.

Aluminium Flexible Ducting (10m)	
Diameter	Stock Ref. No.
100mm	105 39 100
125mm	105 39 125
150mm	105 39 150
200mm	105 39 200
250mm	105 39 250
315mm	105 39 315
400mm	105 39 400



Insulated Flexible Ducting

Insulated ducting should be used when duct passes through an unheated area. Minimized heat loss when used with Heat Recovery fans. Available in 6 diameters.

10m length. An additional benefit is that thermally insulated duct offers some measure of acoustic attenuation.

Fire Rating: When assessed against the integrity criterion of **BS476: Part 20; 1987**, the ducting is capable of providing in excess of **25 minutes** integrity from inside to outside.

Insulated Flexible Ducting (10m)	
Diameter	Stock Ref. No.
100mm	56 16 54
125mm	56 16 55
150mm	56 16 56
200mm	56 16 58
250mm	56 16 60
315mm	56 16 62

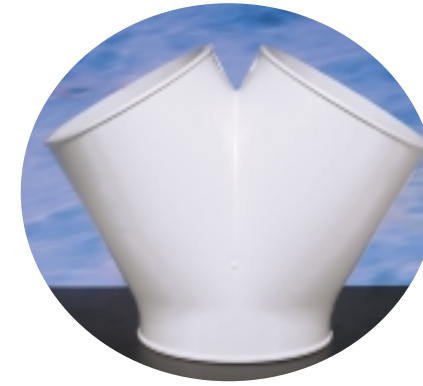

Duct Y Pieces

For dividing a ventilation system, providing ducting to multiple supply or extract grilles using only a single fan source. Available in fire retardant ABS.

Vent-Axia Duct Y Piece		
2 x	Into 1 x	Stock Ref. No.
100	100	45 20 81
100	150	45 20 82
125	125	45 52 11
125	150	45 52 12
150	150	45 20 83
150	200	45 20 84
200	200	45 20 85
200	250	45 20 78
200	300	45 20 80
250	250	45 20 76
250	300	45 20 79
300	300	45 20 77

All diameters are in millimetres



3-Way Splitters

Manufactured from high impact polymeric material which is flame retardant with a maximum operating temperature of +50°C.

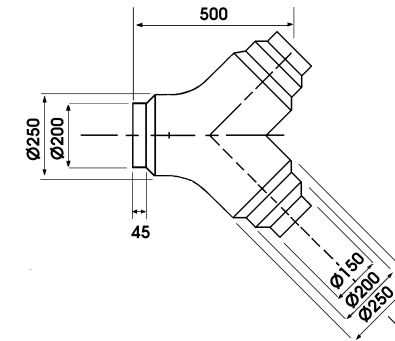

Stock Ref. No. 105 51 250

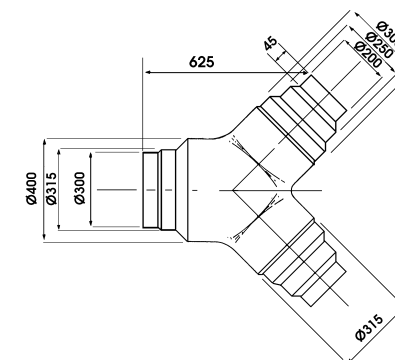

Stock Ref. No. 105 53 400

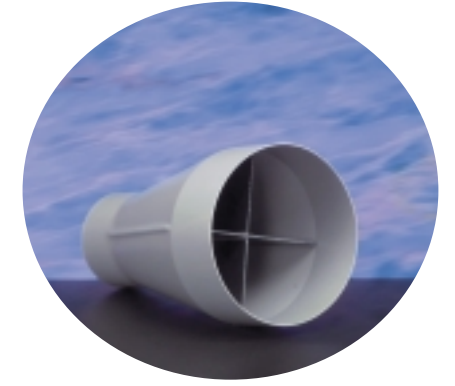

Cone Connectors

Used in conjunction with a Size 6 *Standard Panel model to reduce the outlet spigot (175mm dia.) to 100mm dia. flexible or rigid ducting.

The Cone connector is 280mm long and incorporates a splitter for improved performance.

Manufactured in flame retardant, high impact thermoplastic. Colour: Grey.

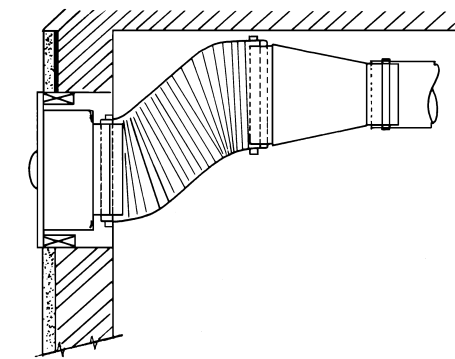

* Not for use with T-Series Range.

Vent-Axia cone connector		
Unit size	Model	Stock Ref. No.
Size 6	Panel	56 09 36

Ventilation Accessories

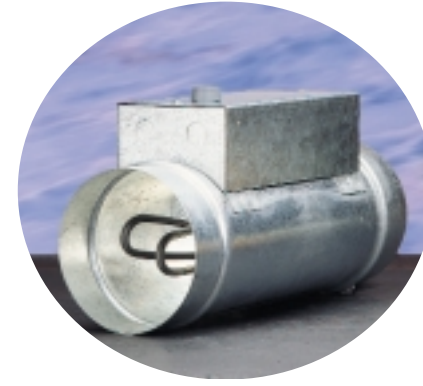
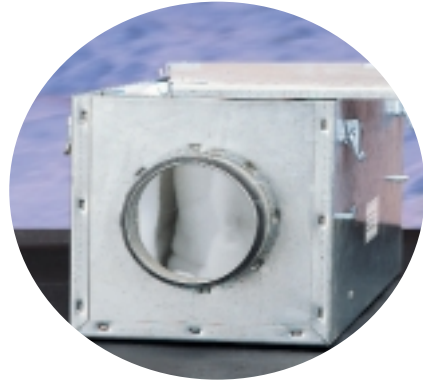

Bag Filter Cassettes

Bag filter cassettes are available in a range of seven sizes. The synthetic filter medium is to EU5 Eurovent 4/5 94% arrestance. The housing is galvanised sheet metal with spigots fitted with integral seals. Quick release catches allow easy access to the bag filter. Replacement bag filters are available.

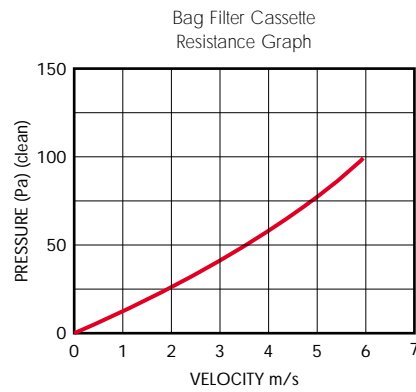

Diameter	Stock Ref. No.	Spare filter
100mm	105 33 100	105 57 150
125mm	105 33 125	105 57 150
150mm	105 33 150	105 57 150
200mm	105 33 200	105 57 200
250mm	105 33 250	105 57 250
315mm	105 33 315	105 57 315
400mm	105 33 400	105 57 400

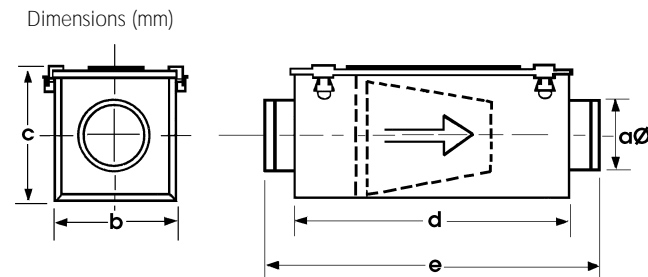

Stock Ref. No.	Øa	b	c	d	e	kgs
105 33 100	100	200	203	450	540	4
105 33 125	125	200	203	450	540	4
105 33 150	150	200	203	450	540	4
105 33 200	200	245	248	450	560	5
105 33 250	250	295	298	500	620	7
105 33 315	315	345	348	550	670	8.5
105 33 400	400	445	448	650	770	12

Pre-Filter Cassettes

Pre-filter cassettes are available in a range of seven sizes and are tested to EU3 (Eurovent 4/5) 85% arrestance. Housing is in galvanised sheet metal. Spigots are fitted with integral seals. Quick release catches allow access to the filter medium. Replacement pre-filters are available.

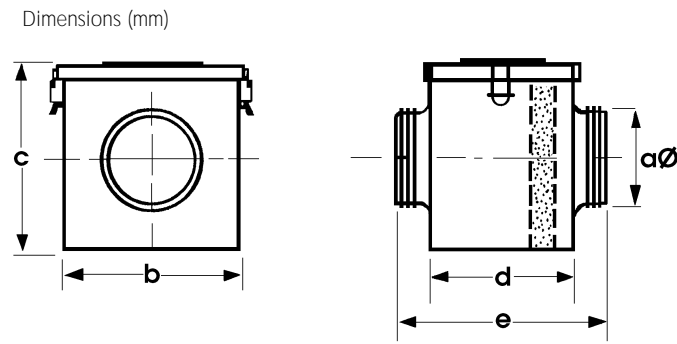
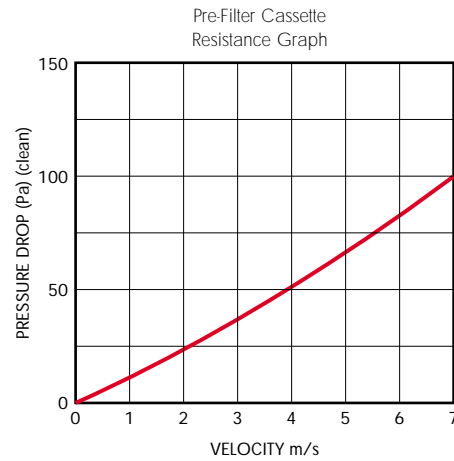

Stock Ref. No.	Øa	x	b	x	c	x	d	x	e	kg
105 32 100A	100		205		170		120		227	2
105 32 125A	125		215		205		140		252	2
105 32 150A	150		265		235		155		267	3
105 32 200A	200		315		275		180		302	3.5
105 32 250A	250		365		325		230		352	5.5
105 32 315A	315		425		390		330		452	7
105 32 400A	400		515		495		455		487	10.5

Vent-Axia pre-filter cassettes			Spare filters (5 per pack)	
Diameter	Stock Ref. No.	Stock Ref. No.	Stock Ref. No.	Stock Ref. No.
100mm	105 32 100A	105 56 100		
125mm	105 32 125A	105 56 125		
150mm	105 32 150A	105 56 150		
200mm	105 32 200A	105 56 200		
250mm	105 32 250A	105 56 250		
315mm	105 32 315A	105 56 315		
400mm	105 32 400A	105 56 400		

Duct Air Heater

Circular Duct Air Heaters comprising of electric resistance elements, mounted in a pre-galvanised steel casing. Every heater is fitted with a high temperature safety cut out operating at 120°C complete with push button manual reset.

Available in 100, 125, 150, 200, 250, 315 and 400mm diameter sizes. The air velocity across the heater elements must be greater than 2m/s and installed a minimum distance of one metre from the exhaust outlet of the fan unit. All fans supplying heaters above 6 kW should be fitted with an off-delay timer to dissipate any residual heat when the system is shut down.

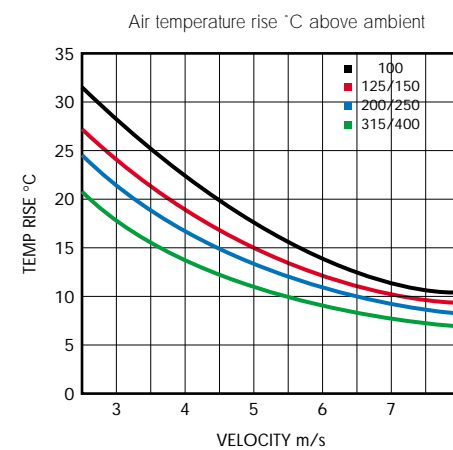
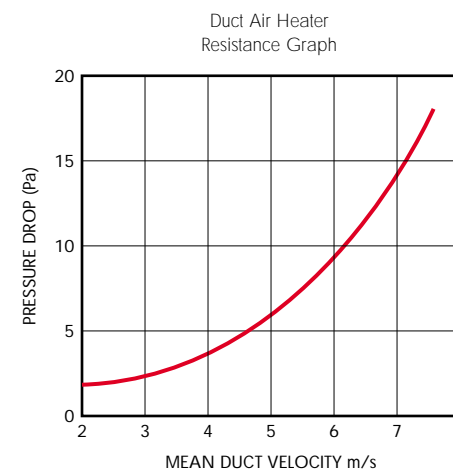

Dimensions (mm)

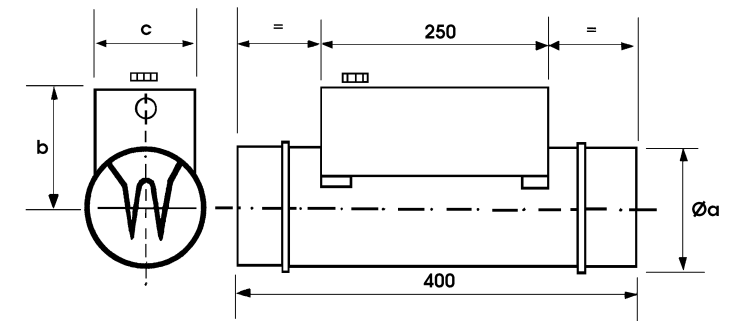

Stock Ref. No.	Øa	b	c	kg
105 31 100	100	100.0	90	2
105 31 125	125	112.5	115	2
105 31 150	150	125.0	115	2.5
105 31 200	200	150.0	180	3.5
105 31 250	250	175.0	180	4.0
105 31 315	315	207.5	180	5.0
105 31 400	400	250.0	230	8.0

Vent-Axia duct air heaters					
Stock Ref. No.	Diameter	kW	Stages	Phase	Amps
105 31 100	100mm	0.75	1	1	3.3
105 31 125	125mm	1.0	1	1	4.4
105 31 150	150mm	1.5	1	1	6.5
105 31 200	200mm	2.0	1	1	8.7
105 31 250	250mm	3.0	1	1	13.1
105 31 315	315mm	4.5	1	1/3	14.6
105 31 400	400mm	9.0	1	1/3	39.1
105 31 315	315mm	4.5	1	3	5 per phase
105 31 400	400mm	9.0	1	3	13 per phase

Duct heaters must be used in conjunction with a fan heater controller and a temperature thermostat (room or duct) and an air pressure/flow switch.

Ventilation Accessories

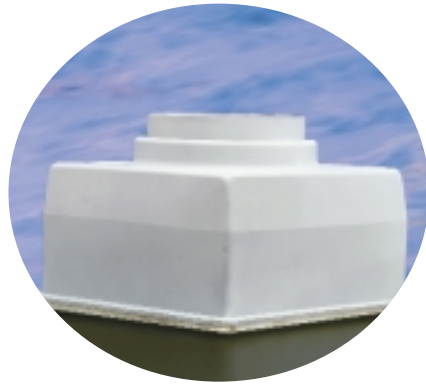

Plenum Boxes

The Plenum box allows square grilles and diffusers to connect to circular duct. Each box size has a two diameter circular spigot for maximum versatility. The box is deep enough to accommodate both a double deflection grille and opposed blade damper.

Manufactured in flame retardant high impact recyclable thermoplastic.

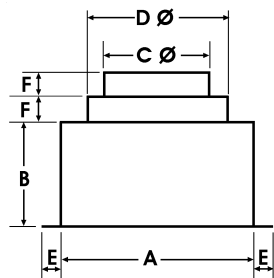
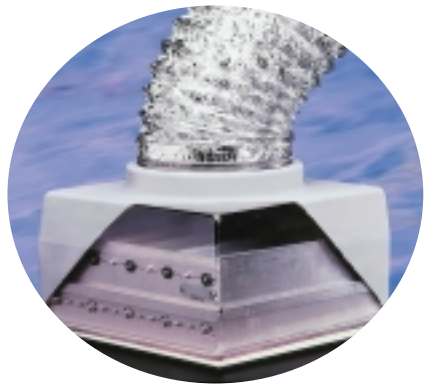

Vent-Axia plenum box						
Stock Ref. No.	A	B	C Ø	D Ø	E	F
56 06 01	200	130	125	150	25	25
56 06 02	250	130	150	175	25	25
56 06 03	300	130	200	225	25	25
56 06 04	300	130	250	300	25	25
56 06 05	450	130	315	400	25	25



Single Deflection Grilles

Single deflection grilles are suitable for either sidewall or exposed duct applications.

The Single deflection grille has a single row of blades which permit up to 45° deflection of the air in one plane.

Satin silver finish.

Size 6/7 fits 300mm square modular size and size 9/12 fits 450mm square modular size.

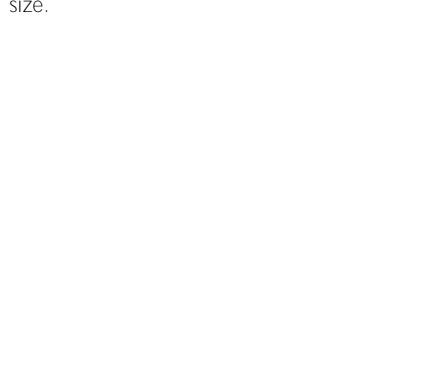

Double Deflection Grilles

Double deflection grilles are suitable for supply air for either sidewall or exposed duct applications.

The Double deflection grille has two rows of blades set at 90° apart which permit up to 45° deflection of the air in two planes.

Satin silver finish.

Size 6/7 fits 300mm square modular size and size 9/12 fits 450mm square modular size.

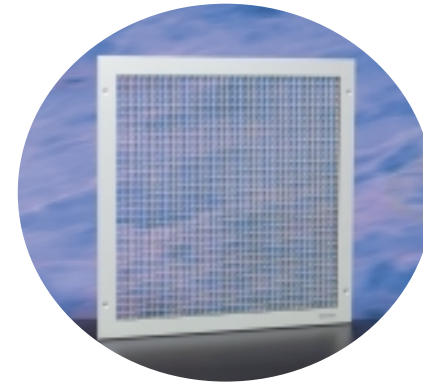
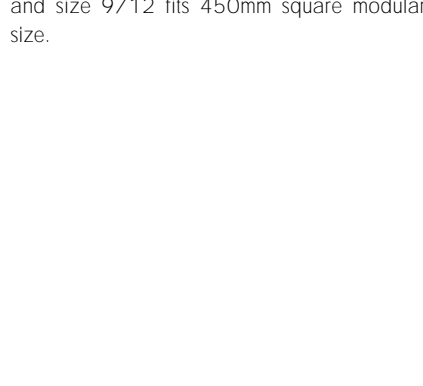

Eggcrate Grilles - Satin

Eggcrate grilles can be used for air replacement or air extract purposes.

Used underneath Roof plate assemblies with Roof models, underneath Single spigots in ceilings, underneath Mounting boxes and on the inside faces of walls that have units in Fixed and Removable wall plates on the outside of the wall.

Comprising a 13mm square by 13mm deep mesh eggcrate core housed in a frame which has a satin silver or white finish.

Size 6/7 fits 300mm square modular size and size 9/12 fits 450mm square modular size.

Size 6/7 - 785cm² free area
Size 9/12 - 1810cm² free area

Vent-Axia eggcrate grilles satin silver finish		
Unit size	Module size	Stock Ref. No.
Size 6/7	300mm □	56 13 01
Size 9/12	450mm □	56 13 02

Also available in the following sizes:-

200mm □	56 13 03
250mm □	56 13 05

Vent-Axia eggcrate grilles white finish		
Unit size	Module size	Stock Ref. No.
Size 6/7	300mm □	56 08 49
Size 9/12	450mm □	56 08 50

Also available in the following sizes:-

125mm □	56 08 46
200mm □	56 08 47
250mm □	56 08 48

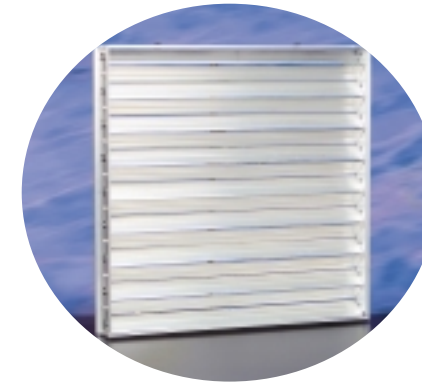

Opposed Blade Dampers

Opposed blade dampers are used to regulate air flow through all Vent-Axia grilles and diffusers. Key operated.

This action ensures that the downstream airflow is non-directional when the damper is in the partially closed position. Opposed blade dampers have aluminium blades and the frame is left in natural mill finish.

Can be used in conjunction with Eggcrate, Single deflection and Double deflection grilles.

Size 6/7 fits 300mm square modular size and size 9/12 fits 450mm square modular size.

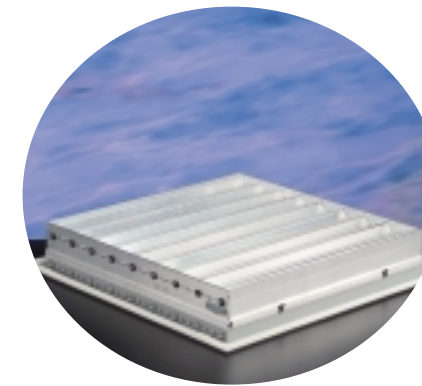

Vent-Axia opposed blade dampers		
Unit size	Module size	Stock Ref. No.
Size 6/7	300mm □	56 13 43
Size 9/12	450mm □	56 13 44

Also available in the following sizes:-

200mm □	56 13 41
250mm □	56 13 42



4 Way Diffusers

Manufactured in polypropylene plastic. Four diffuser cassettes can be set for downward or 45° discharge in any of sixteen directional combinations.

Vent-Axia 4-way diffusers		
Neck Size	Colour	Stock Ref. No.
225mm	Ivory	105 46 230
300mm	Ivory	105 46 300A
350mm	Ivory	105 46 350
400mm	Ivory	105 46 400
450mm	Ivory	105 46 450
500mm*	Ivory	105 46 500

*Fits ceiling grid size 600mm □, 595mm □ overall diffuser size



Neck Adaptor

Used to connect Flexible ducting directly to 4-way diffusers. Integral volume control damper for duct sizes up to 300mm.

Vent-Axia neck adaptors		
4-way diffuser size	Duct dia.	Stock Ref. No.
225mm	150mm	105 47 150
225mm	200mm	105 47 200
300mm	250mm	105 47 250
350mm	300mm	105 47 300
400mm	400mm	105 47 400
450mm	400mm	105 48 400
500mm	315/400mm	105 48 000

Ventilation Accessories



Window/Wall/Ceiling Termination Sets

Used to terminate Flexible ducting at windows. Can be used with the Extended fixing rod set or Fixing plates for termination at walls. Used with Flexible ducting and Worm drive clips.

Consists of: Direct mount spigot, Adaptor kit, Window grille and all screws.

Unit size	Window Fixing hole diameter	Wall Duct Size
Size 6	184mm	175mm
Size 7	222mm	225mm
Size 9	260mm	300mm
Size 12	337mm	400mm

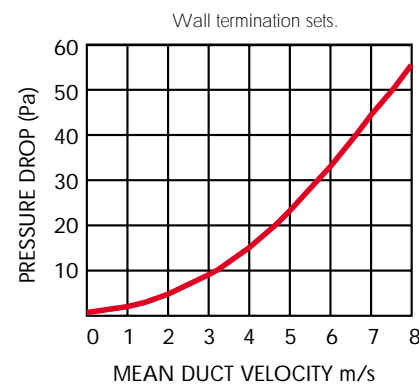

Spigot Dia.	Vent-Axia wall termination Grille Size 'A' H x W	Hole req'd in wall Ø	Hole req'd in window Ø	Stock Ref. No.
100mm	220 x 226	210	184	W105 54 150
125mm	258 x 265	240	222	W105 54 200
150mm	302 x 304	290	260	W105 54 250
200mm	378 x 381	370	337	W105 54 315

Unit size	Spigot Ø	Stock Ref. No.	Window/wall
Size 6	175	W56 01 51	
Size 7	225	W56 01 52	
Size 9	300	W56 01 53	
Size 12	400	W56 01 54	



Air Replacement Non-Vision Grilles

Satin finish

Non-vision grilles consist of a single row of overlapping chevron vanes. Used as transfer grilles for doors or partitions, the overlapping vanes prevent through-vision.

Black finish

In addition to preventing through-vision the black finish also limits light transference. Use two grilles back to back for darkroom applications.

Available in 300mm square and 450mm square modular sizes.

Size 6/7 - 350cm² free area
Size 9/12 - 955cm² free area



Unit size	Module size	Finish	Stock Ref. No.
Size 6/7	300mm □	Satin Black	56 13 11 56 13 21
Size 9/12	450mm □	Satin Black	56 13 12 56 13 22



Roof Termination Sets

Used to terminate Flexible ducting at roofs. See also Roof plate assemblies and Soaker flanges [page 181](#), Fixing plates on this page.

Consists of: Direct mount spigot, Adaptor kit, Roof cowl, Deflector and all screws.

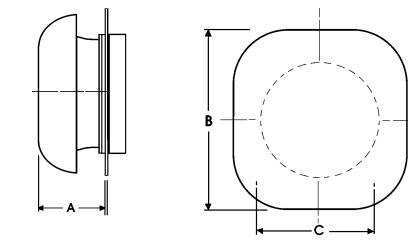
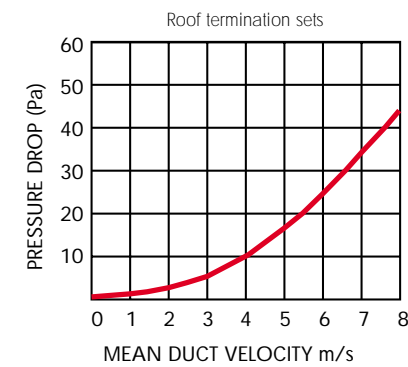

Diameter	a	b	cØ	Stock Ref. No.
100mm				
125mm	100	285	184	105 55 150
150mm				
200mm	136	400	222	105 55 200
250mm	136	400	260	105 55 250
315mm	171	500	337	105 55 315

Unit size	Spigot Ø	Stock Ref. No.	Roof
Size 6	175	56 01 61	
Size 7	225	56 01 62	
Size 9	300	56 01 63	
Size 12	400	56 01 64	



Air Replacement Non-Vision Door Grilles with Matching Flanges

Non-vision grilles consist of a single row of overlapping chevron vanes to prevent through-vision, supplied with matching flanges.

The grille is fitted to one side of the door with the matching flange on the other side.

Suitable for door thicknesses of 19-49mm.

Available in Silver or Brown finish, in two sizes, 600 x 150 and 600 x 300mm.

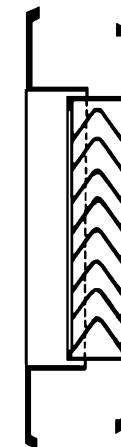

Dimensions as T-Series panel unit A, B, D and J, see [page 111](#).

Size	Finish	Stock Ref. No.
600 x 150mm	Silver	56 13 90
	Brown	56 09 00
600 x 300mm	Silver	56 13 91
	Brown	56 09 01



External Louvres Mill and Brown Finish

Weather resistant external louvres are suitable for air intake or discharge and for use with ducting on external walls.

The narrow blade construction has a 38mm pitch set at 45° with a depth of 41mm and an integral rain lip.

Standard 32mm wide undrilled outer flanges in aluminium have fully welded mitre corners as standard.

Size 6/7 fits 300mm square modular size and size 9/12 fits 450mm square modular size.

Size 6/7 - 345cm² free area
Size 9/12 - 824cm² free area

Unit size	Module size	Stock Ref. No.
Size 6/7	300mm □	56 13 51
Size 9/12	450mm □	56 13 52
Also available in the following sizes:-		
	225mm □	56 13 50
	400mm □	56 13 55

Unit size	Module size	Stock Ref. No.
Size 6/7	300mm □	56 09 11
Size 9/12	450mm □	56 09 13
Also available in the following sizes:-		
	225mm □	56 09 10
	400mm □	56 09 12



Louvred Grilles

Louvred grilles can be used for air replacement, for extract purposes and as an external louvre. Available in four sizes, the assembly fits over rather than into the aperture making it especially useful where there are space restrictions within the duct.

Manufactured in thermoplastic. Choice of three colours: White, Brown and Grey.

Size 6 - 190cm² free area
Size 7 - 335cm² free area
Size 9 - 415cm² free area
Size 12 - 705cm² free area

The grilles and surrounds are moulded in ABS plastic to tone with building materials, therefore an equivalent BS or RAL colour reference cannot be given.

Dimensions as T-Series panel unit B, D and J, see [page 111](#).

Unit size	Colour	Stock Ref. No.	Recommended hole size
Size 6	Grey	W56 14 31	230mm □
	White	56 14 21	
	Brown	56 14 11	
Size 7	Grey	W56 14 32	270mm □
	White	56 14 22	
	Brown	56 14 12	
Size 9	Grey	W56 14 33	300mm □
	White	56 14 23	
	Brown	56 14 13	
Size 12	Grey	W56 14 34	380mm □
	White	56 14 24	
	Brown	56 14 14	

Ventilation Accessories



Filtered Inlet Grille

For ceiling, panel or glass mounting. Consists of a size 6 grille, washable filter, adaptor kit and a stepped spigot to suit 100, 125 or 150mm diameter ducting.
Grille size: 226mm x 220mm
Spigot depth: 100mm
Fixing hole diameter 184mm
Stock Ref. No. W56 35 36

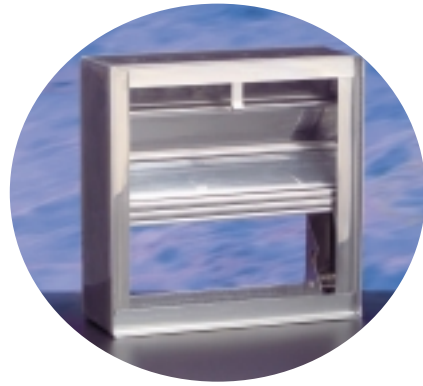

Fire Dampers

Available in 300mm and 450mm square modular sizes. For use with other modular accessories when a duct passes through a ceiling or wall requiring a damper to be fitted.

Concertina type with 71°C fusible link 2 hour rated.

Manufactured in stainless steel.

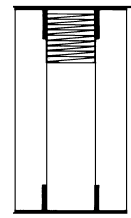

107

Unit size	Vent-Axia fire damper Module size	Stock Ref. No.
Size 6	300mm □	56 19 01
Size 7	300mm □	56 19 01
Size 9	450mm □	56 19 02
Size 12	450mm □	56 19 02



5-Core Flexible Cord

Multi-core flexible cord specially manufactured for use with all Vent-Axia Standard and T-Series units. White sheath with colour coded cores. Available by the metre (minimum 5m) or by the 50 metre coil.

Cable size: 0.75mm²

Cut lengths (per metre):
Stock Ref. No. 56 20 30

50 metre coil:
Stock Ref. No. 56 20 31



Joining Pieces

Used to join lengths of flexible ducting to give a long-lasting airtight connection.

Vent-Axia joining piece		
Unit size	Duct size	Stock Ref. No.
Size 6	100mm dia.	56 18 04
	175mm dia.	56 18 07
	225mm dia.	56 18 09
Size 7	225mm dia.	56 18 09
	250mm dia.	56 18 10
Size 9	300mm dia.	56 18 12
Size 12	400mm dia.	56 18 16

Also available in the following sizes:
125mm dia. 56 18 05
150mm dia. 56 18 06
200mm dia. 56 18 08
315mm dia. 56 18 13



Worm Drive Clips

Stainless steel tightening band with quick-fix screwed ends for securing flexible ducting.

Vent-Axia worm drive clip			
Unit size	Duct size	max. dia	Stock Ref. No.
Size 6	100mm dia.	110mm	56 17 04
	175mm dia.	180mm	56 17 07
	225mm dia.	270mm	56 17 10
Size 7	225mm dia.	270mm	56 17 10
	250mm dia.	270mm	56 17 10
Size 9	300mm dia.	380mm	56 17 15
Size 12	400mm dia.	525mm	56 17 20
		660mm	56 17 26

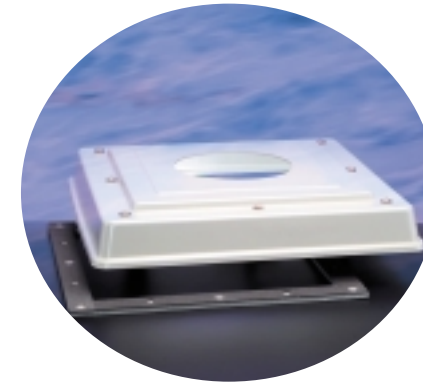

Roof Plate Assemblies

Vent-Axia roof plate assemblies are manufactured in high impact recyclable thermoplastic. They consist of a strong one piece moulded plate with extended sides to assist flashing and weather protection. A separate sub-frame is provided for permanent fixing to the roof kerb. The Vent-Axia Roof model is then fitted to the plate using a suitable sealing compound between the Cowl and plate, ensuring a weather-tight seal.

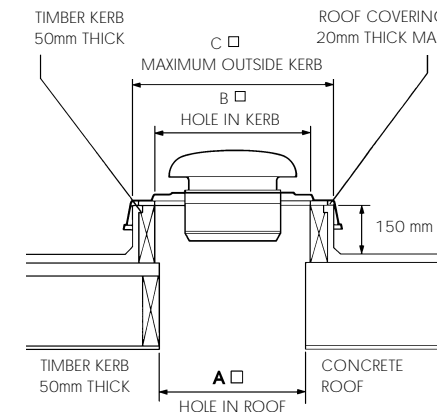

Size	A □	B □	C □
6	300mm	335mm	475mm
7	300mm	335mm	475mm
9	450mm	490mm	630mm
12	450mm	490mm	630mm

Vent-Axia roof plate assembly	
Unit size	Stock Ref. No.
Size 6	56 01 36
Size 7	56 01 37
Size 9	56 01 39
Size 12	56 01 42

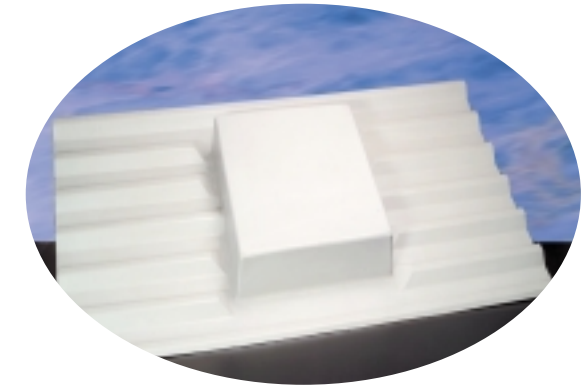

Soaker Flanges

Soaker flanges are a simple and neat solution to the problem of installing units in vertical corrugated walls and pitched corrugated roofs.

The existing corrugated sheet is removed and the correct profile replacement sheet is fixed in its place. The top end of the sheet is fitted underneath either the sheet above or the ridge tiles to provide weather protection at the top.

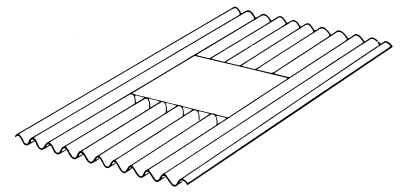

Soaker flanges are manufactured in GRP and are supplied with a central flat section with four hole sizes marked out ready for cutting to suit whichever size unit is being installed. The unit is then fitted and the cowl should be bedded down with a suitable sealing compound.

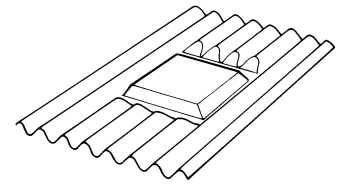

THESE ARE SAMPLE PROFILES ONLY, MANY MORE ARE AVAILABLE. WHEN ORDERING PLEASE SPECIFY PROFILE REQUIRED AND SIZE AND TYPE OF FAN TO BE USED.

Profile	Vent-Axia soaker flanges	Colour
Standard 3		White
Big 6		Goosewing Grey
Atlas Major Tile		Goosewing Grey
Monad		Goosewing Grey
Double 6M		Goosewing Grey
Moduclad A1000		Goosewing Grey
Trafford Tile		Goosewing Grey
R34		Goosewing Grey
R38		Goosewing Grey

Other profiles are available