

VENT-AXIA ACOUSTIC IN-LINE FANS WIRING DIAGRAMS

SINGLE PHASE FAN CONNECTED TO A D.O.L. STARTER

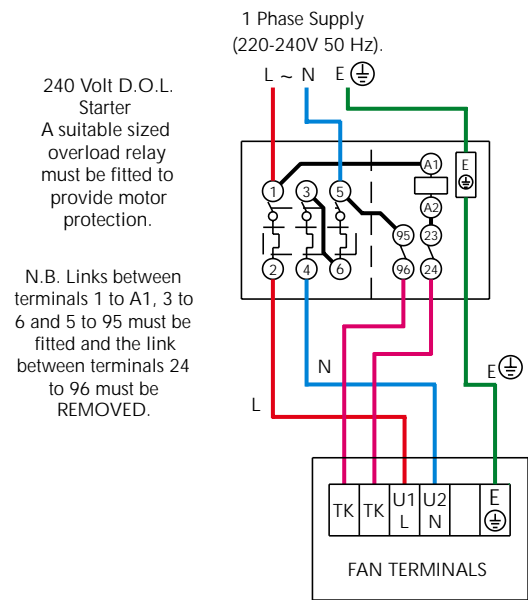

240 Volt D.O.L. Starter
A suitable sized overload relay must be fitted to provide motor protection.

N.B. Links between terminals 1 to A1, 3 to 6 and 5 to 95 must be fitted and the link between terminals 24 to 96 must be REMOVED.

- | | |
|-------------|--------------|
| ACQ 100-12C | ACQ 250-12C |
| ACQ 125-12C | ACQ 315-12LC |
| ACQ 150-12C | ACQ 315-14HC |
| ACQ 160-12C | ACQ 400-14C |
| ACQ 200-12C | ACQ 500-14C |

SINGLE PHASE FAN CONNECTED TO A 2.5 AMP ELECTRONIC SPEED CONTROLLER

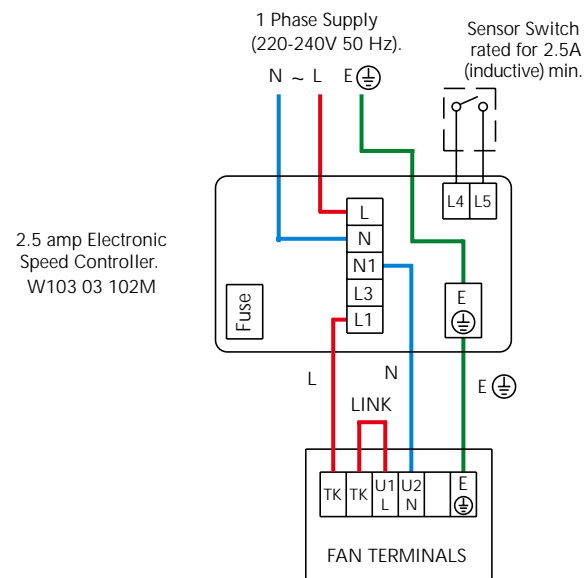

2.5 amp Electronic Speed Controller. W103 03 102M

- | | |
|-------------|--------------|
| ACQ 100-12C | ACQ 250-12C |
| ACQ 125-12C | ACQ 315-12LC |
| ACQ 150-12C | |
| ACQ 160-12C | |
| ACQ 200-12C | |

THREE PHASE FAN CONNECTED TO A 415V COIL D.O.L. STARTER

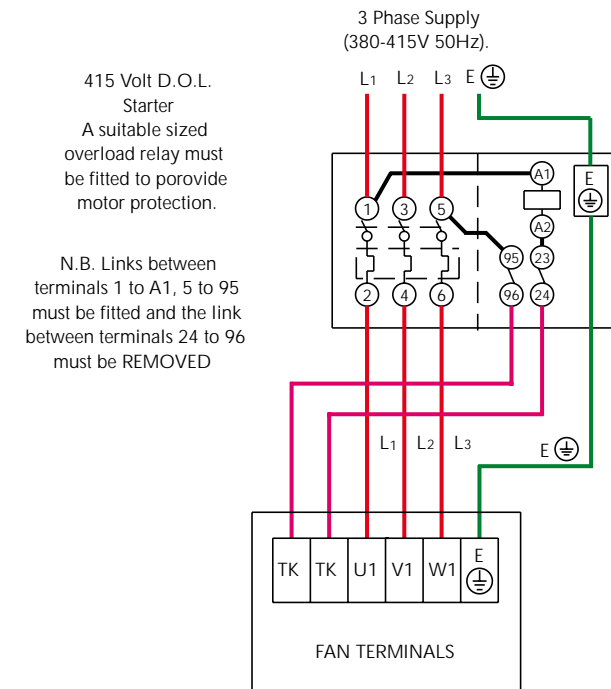

415 Volt D.O.L. Starter
A suitable sized overload relay must be fitted to provide motor protection.

N.B. Links between terminals 1 to A1, 5 to 95 must be fitted and the link between terminals 24 to 96 must be REMOVED

ACQ 500-34C

SINGLE PHASE FAN CONNECTED TO A 3.0, 6.0 OR 10.0 AMP ELECTRONIC SPEED CONTROLLER

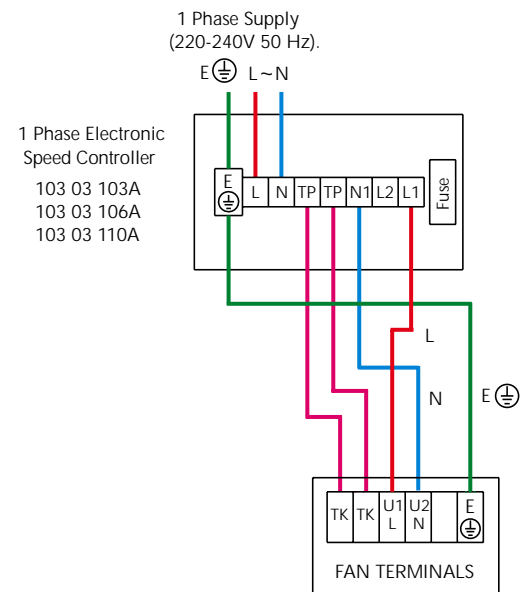

1 Phase Electronic Speed Controller
103 03 103A
103 03 106A
103 03 110A

- | | |
|-------------|--------------|
| ACQ 100-12C | ACQ 250-12C |
| ACQ 125-12C | ACQ 315-12LC |
| ACQ 150-12C | ACQ 315-14HC |
| ACQ 160-12C | ACQ 400-14C |
| ACQ 200-12C | ACQ 500-14C |

SINGLE PHASE FAN CONNECTED TO A 3.0, 5.0, 7.5 OR 13.6 AMP AUTO TRANSFORMER SPEED CONTROLLER

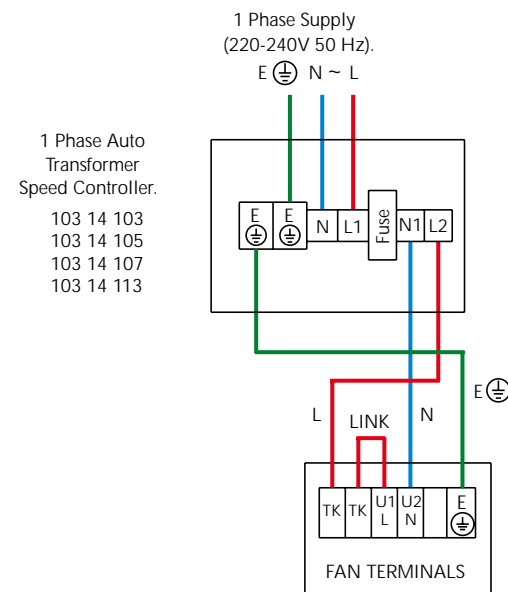

1 Phase Auto Transformer Speed Controller.
103 14 103
103 14 105
103 14 107
103 14 113

- | | |
|-------------|--------------|
| ACQ 100-12C | ACQ 250-12C |
| ACQ 125-12C | ACQ 315-12LC |
| ACQ 150-12C | ACQ 315-14HC |
| ACQ 160-12C | ACQ 400-14C |
| ACQ 200-12C | ACQ 500-14C |

THREE PHASE FAN CONNECTED TO A 4.0 AMP AUTO TRANSFORMER SPEED CONTROLLER

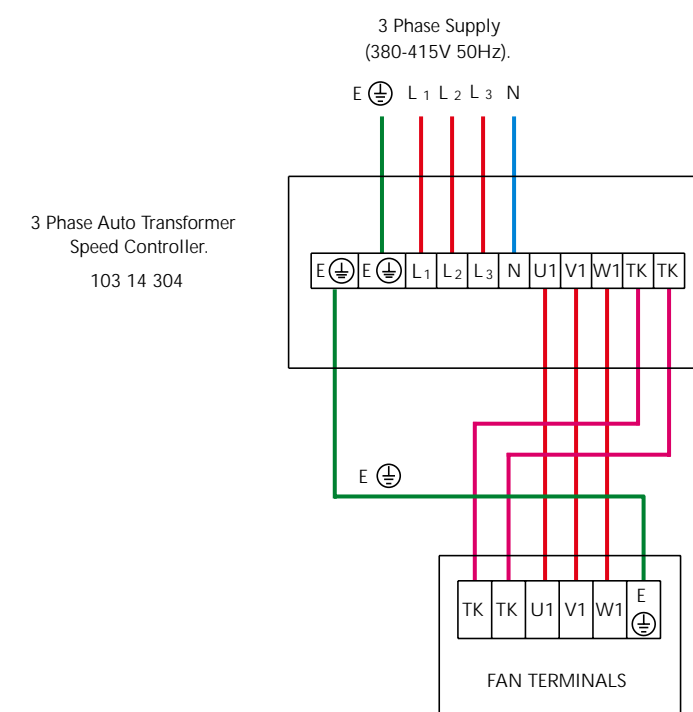

3 Phase Auto Transformer Speed Controller.
103 14 304

ACQ 500-34C

ACOUSTIC IN-LINE FANS WIRING DIAGRAMS