

Vertical Discharge Mixed Flow Roof Fans (RMV)

Features and Benefits

- **Handles air temperatures up to +100°C**
- **Motor mounted outside of the airstream**
- **Manufactured from glass reinforced polyester**
- **IP65 service isolator**
- **Bird guard fitted as standard**
- **Manufacture controlled to BS EN ISO 9001**
- **Performance tested to BS 848 Part 1 & 2**
- **2 Year Guarantee**

The vertical discharge backward curved mixed flow roof fan - the RMV range - is specifically designed for high velocity vertical discharge applications.

The motor is located out of the main airstream in a separately ventilated enclosure to handle continuous in duct air temperatures up to +100°C when in operation. A duct temperature sensor must be used to automatically operate the fan unit to protect the motor from excessive heat whilst idle.

To meet COSHH requirements, a service isolator switch is fitted and pre-wired as standard.

Ideal for many commercial or industrial applications such as kitchen extract systems, the RMV range discharges vertically at high velocity to give fast dilution. Available in six models with extract performance ranging from 0.344m³/s up to 5.62m³/s (1240m³/h to 20240m³/h). With pressure characteristics of up to 1000Pa this range is particularly suitable for ducted applications.

Suitable for horizontal kerb mounting only (maximum angle of 3° from horizontal).

For pitched roof applications a special upstand will be needed to compensate for the angular difference - not supplied.

Motors

The motor is mounted on a corrosion resistant stainless steel support in a ventilated enclosure out of the airstream and drives a highly efficient aluminium, mixed flow impeller which offers non-overloading characteristics.

The motors are rated at IP54 to BS EN 60529, the bearings are greased for life. Insulation is Class 'B'. The motor is pre-wired to a service isolator protected to IP65 with 20mm entry fitted as standard and providing local isolation conforming to the latest COSHH regulations.

Protection of the motor is provided by a current overload protection switch (DOL Starter) which is required on all installations. Sizes 500 and 560, 3ph 4 pole must be wired STAR/DELTA or the guarantee will be invalidated.

Electrical

Single phase 220-240V 50 Hz. Capacitor start and run. Three phase 380-415V 50 Hz.

Models are available with 4 and 6 pole motors.

Sound Levels

Published dB(A) figures are free field sound pressure levels at 3m with spherical propagation at a reference level of 2 x 10⁻⁵Pa

(20 micro-Pascal). The sound power level spectra figures are dB with a reference level of 10⁻¹² Watts (1 pico-watt).

Accessories

Roof attenuators

Available in three lengths: 600, 900 or 1200mm according to the attenuation required.

Shutters

Made of a robust construction and designed to fit beneath the fan using the fittings provided. Airflow operated. A minimum distance of half the attenuator width is required between an airflow shutter and a roof attenuator for satisfactory operation. When shutters are fitted the maximum temperature permissible is 50°C.



Details of Kerb Mounting

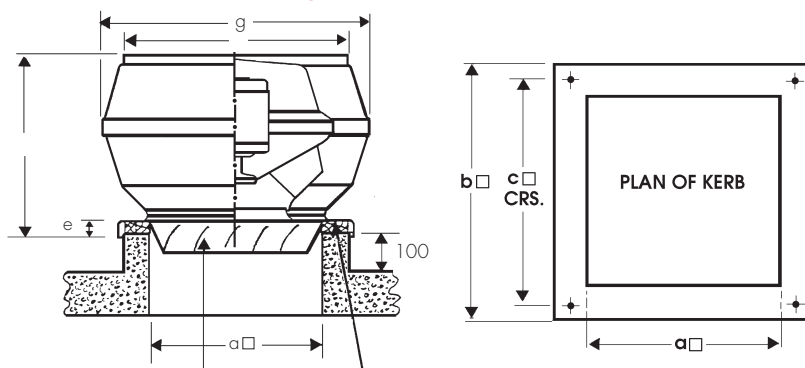

Air operated shutter (optional accessory.)
Fan unit secured to hardwood sill with coach screws or similar.

Fan size	a	b	c	d	e	Øf	Øg
RMV200	300	400	330	400	40	404	500
RMV280	400	525	450	487	40	571	700
RMV355	400	600	560	563	50	622	770
RMV450	500	660	620	642	50	718	900
RMV500	650	850	800	709	50	890	1060
RMV560	650	850	800	801	50	988	1200

Typical Installation

Bird Guard fitted as standard

A Current Overload Protection switch (DOL or STAR/DELTA starter) is required on all installations.

Suitable for horizontal mounting only. For pitched roof applications a special upstand will be needed to compensate for the angular difference - to be manufactured by others.

Vertical discharge fan suitable for handling continuous air temperatures up to 100°C when in operation. A duct temperature sensor must be used to automatically operate the fan unit to protect the motor from excessive heat whilst idle.

IP65 Isolator fitted as standard

Vent-Axia rectangular roof attenuator

Airflow guide vanes

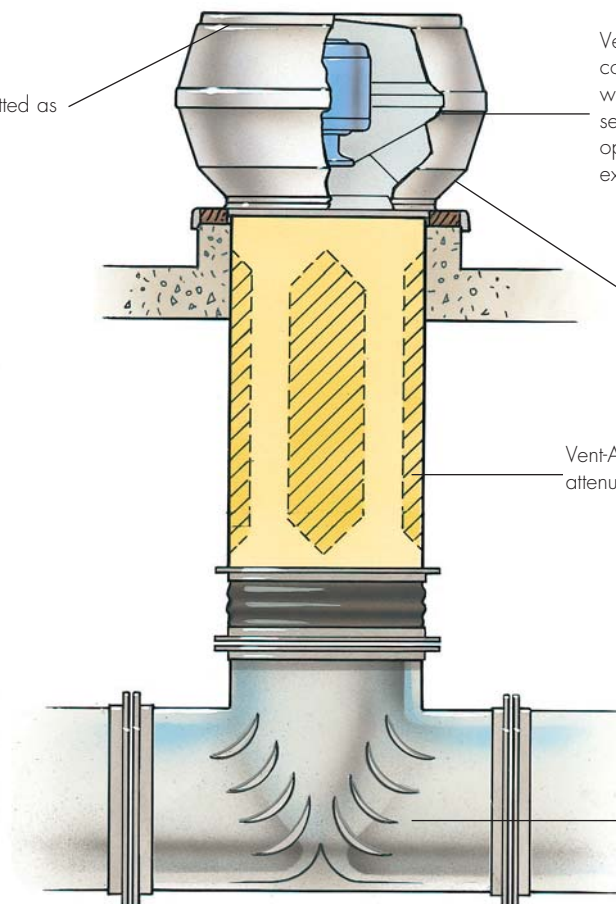

Vertical Discharge Mixed Flow Roof Fans (RMV)

Performance Curves

200 - 560 dia. - 4 Pole - 1 & 3 Phase

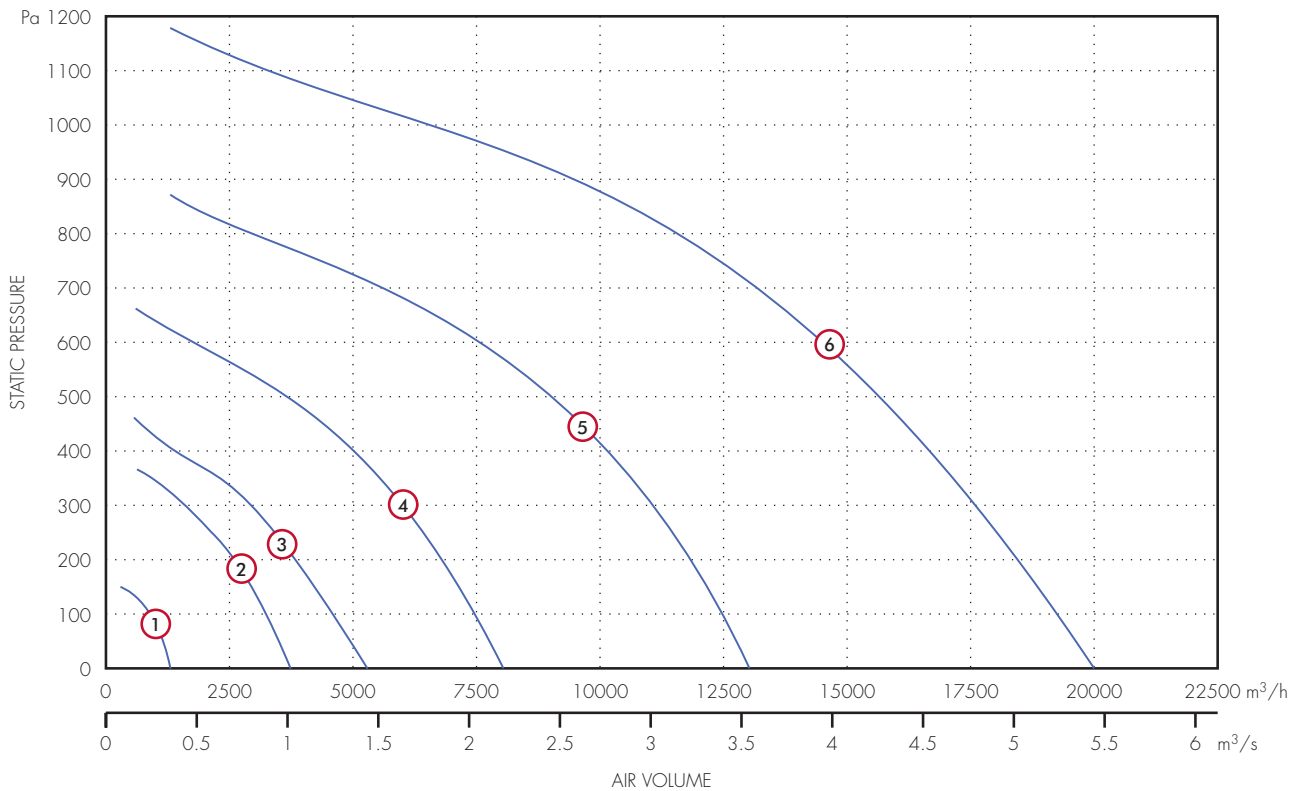

Performance Guide

Dia.	Phase	Stock Pole	Stock Ref.	Curve r.p.m.	Curve Ref.	m³/s at Pa										Motor kW	S.C. Amps	F.L.C. Amps	dBA @ 3m	
						0	25	50	100	150	200	250	300	350	400					
200	1	4	RMV20014	1320	①	0.345	0.317	0.289	0.226	0.091							0.095	1.1	0.44	44
280	1	4	RMV28014	1340	②	1.044	1.008	0.972	0.9	0.819	0.725	0.605	0.425	0.2			0.41	4.2	1.97	56
355	1	4	RMV35514	1320	③	1.475	1.416	1.366	1.266	1.18	1.075	0.97	0.83	0.661	0.425	0.775	14	3.5	60	
355	3	4	RMV35534	1320	③	1.475	1.416	1.366	1.266	1.18	1.075	0.97	0.83	0.661	0.425	0.78	7.2	1.5	60	
450	3	4	RMV45034	1430	④	2.247	2.222	2.165	2.075	2.02	1.92	1.813	1.683	1.564	1.421	1.55	12	2.95	64	
500	3	4	RMV50034	1425	⑤	3.669	3.63	3.59	3.514	3.423	3.333	3.229	3.113	2.995	2.88	3.6	34	6.9	69	
560	3	4	RMV56034	1415	⑥	5.62	5.601	5.532	5.462	5.347	5.25	5.15	5.025	4.9	4.72	6.5	58	11.6	72	

TEMPERATURE RANGE

The range is designed to handle duct air temperatures from -30°C to + 100°C on a continuous operation basis. The external ambient temperature should not exceed + 40°C.

S.C. = STARTING CURRENT
F.L.C. = FULL LOAD CURRENT

Sound Power Level Spectra dB (re 10⁻¹² Watts)

Stock Ref. No.	Pole	125	250	500	1k	2k	4k	8k
RMV20014	4	67	63	62	61	56	49	38
RMV28014	4	79	76	75	71	69	60	52
RMV35514	4	86	81	78	75	72	66	55
RMV35534	4	86	81	78	75	72	66	55
RMV45034	4	89	86	83	77	74	69	58
RMV50034	4	94	92	88	81	77	71	61
RMV56034	4	99	94	91	87	80	75	66

Performance Curves

355 - 560 dia. - 6 Pole - 1 & 3 Phase

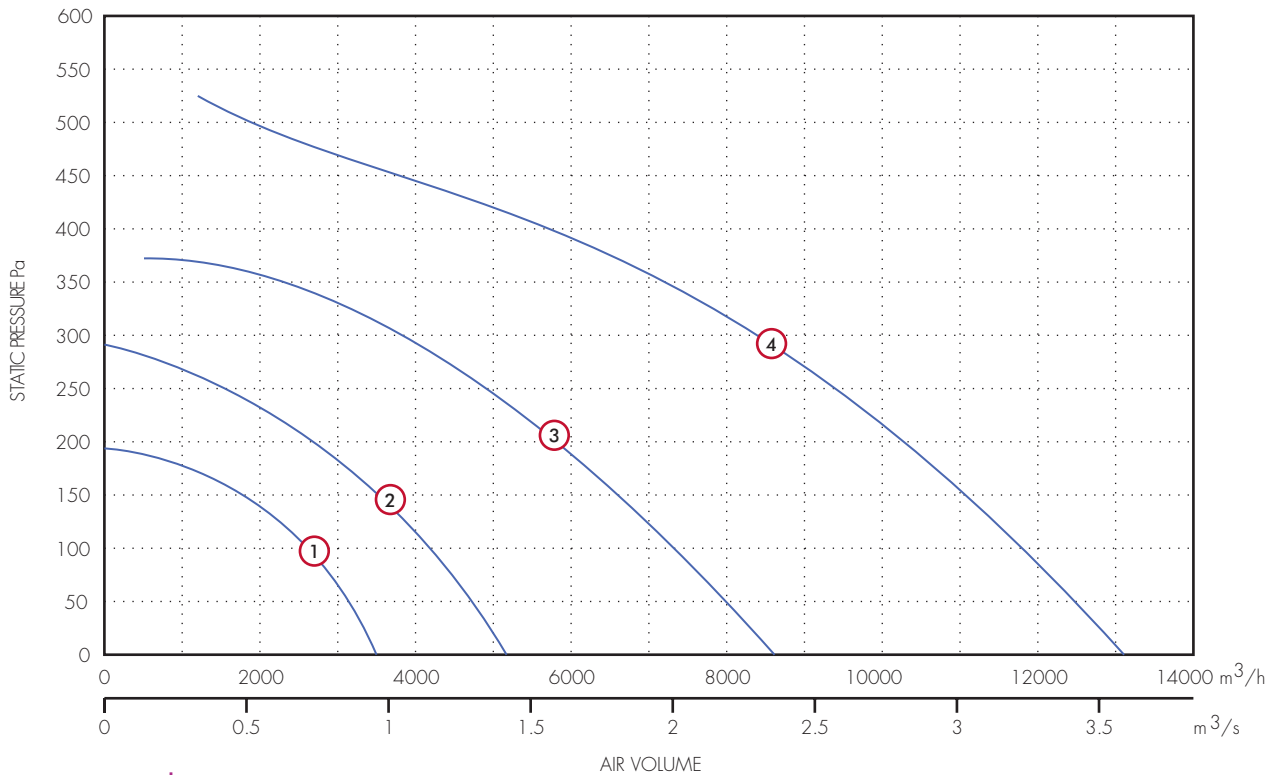

Performance Guide

Dia.	Phase	Motor Pole	Stock Ref.	Curve r.p.m.	Curve Ref.	m³/s at Pa								Motor kW	S.C. Amps	F.L.C. Amps	dBA @ 3m		
						0	25	50	100	150	200	250	300					350	400
355	1	6	RMV35516	880	①	0.966	0.907	0.846	0.704	0.455						0.3	3.4	1.34	51
355	3	6	RMV35536	880	①	0.966	0.907	0.846	0.704	0.455						0.35	2.2	0.85	51
450	1	6	RMV45016	910	②	1.462	1.4	1.322	1.16	0.855	0.71					0.54	7.5	2.66	54
450	3	6	RMV45036	910	②	1.462	1.4	1.322	1.16	0.855	0.71					0.47	3.6	1.2	54
500	3	6	RMV50036	960	③	2.383	2.295	2.222	2.026	1.83	1.62	1.385	0.97			1.1	7.2	2.4	58
560	3	6	RMV56036	970	④	3.647	3.565	3.488	3.307	3.1	2.855	2.571	2.286	1.87	1.495	1.95	13	4.2	63

S.C. = STARTING CURRENT

F.L.C. = FULL LOAD CURRENT

TEMPERATURE RANGE

The range is designed to handle duct air temperatures from -30°C to + 100°C on a continuous operation basis. The external ambient temperature should not exceed + 40°C.

Sound Power Level Spectra dB (re 10⁻¹² Watts)

Stock Ref. No.	Pole	125	250	500	1k	2k	4k	8k
RMV35516	6	78	73	69	66	60	53	46
RMV35536	6	78	73	69	66	60	53	46
RMV45016	6	80	77	72	67	63	57	46
RMV45036	6	80	77	72	67	63	57	46
RMV50036	6	84	82	78	70	67	59	51
RMV56036	6	90	86	82	77	69	63	55

Vertical Discharge Mixed Flow Roof Fans (RMV)

Accessories Dimensions (mm)

Roof Attenuators

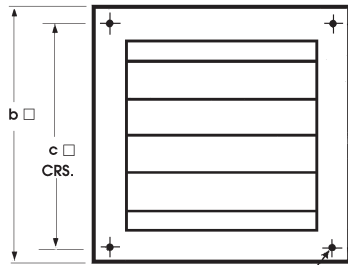
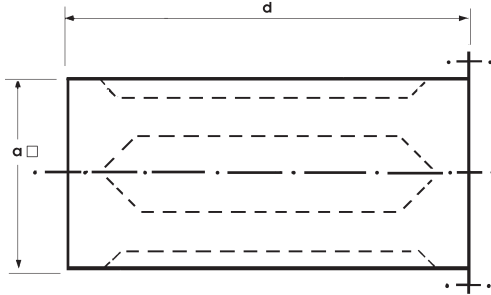

4-HOLES 11.0 DIA.

Air Operated Shutters

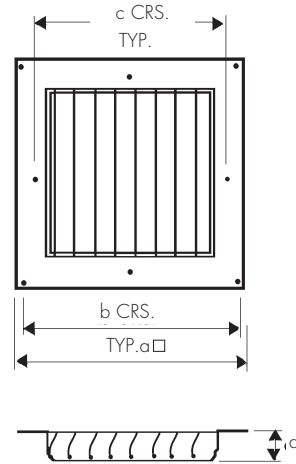

Approx. percentage reduction in performance at 4 Pole speeds

Fan Model	Approx. percentage reduction in performance at 4 Pole speeds
RMV 280	20%
RMV 355	34%
RMV 450	25%

For 6 pole fans, reduce percentages by ratio of fan speeds

When air operated shutters are used in conjunction with roof attenuators, there must be a minimum spacing of half the attenuator width between them.

Stock Ref.	a □	b	c	d
10517315	600	560	470	105
10517400	700	670	570	105

Note:
When shutters are fitted the max. temperature permissible is limited to 50°C

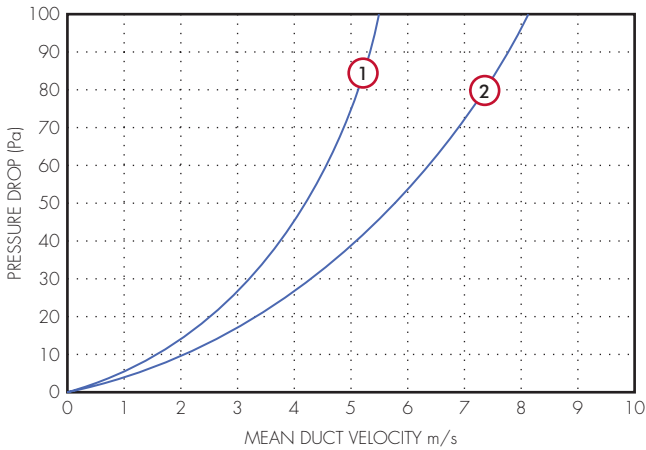

Stock Ref. No.	a □	b □	c □	d	Kg approx	Face area m ²	Resistance curve
10520315	395	495	445	600	18	0.156	①
10520400	495	595	545	600	22	0.245	②
10520500	645	745	695	600	31	0.416	②
10521315	395	495	445	900	21	0.156	①
10521400	495	595	545	900	28	0.245	②
10521500	645	745	695	900	39	0.4160	②
10522315	395	495	445	1200	25	0.1560	①
10522400	495	595	545	1200	35	0.2450	②
10522500	645	745	695	1200	48	0.4160	②

Roof Attenuator, Insertion Losses

Attenuator Length 600mm

Impeller Ø	Stock Ref.	125	250	500	1k	2k	4k	8k
280	10520315	7	12	17	21	22	14	7
355	10520315	4	8	15	17	10	5	1
450	10520400	4	8	15	17	10	5	1
500	10520500	7	10	16	23	24	10	3

Attenuator Length 900mm

Impeller Ø	Stock Ref.	125	250	500	1k	2k	4k	8k
280	10521315	9	15	23	28	30	17	8
355	10521315	5	10	16	19	12	6	1
450	10521400	5	10	16	19	12	6	1
500	10521500	8	13	20	27	28	12	4

Attenuator Length 1200mm

Impeller Ø	Stock Ref.	125	250	500	1k	2k	4k	8k
280	10522315	11	18	29	34	35	19	9
355	10522315	6	11	18	21	14	8	2
450	10522400	6	11	18	21	14	8	2
500	10522500	9	15	24	31	32	14	5

Accessories

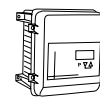
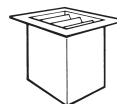
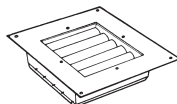
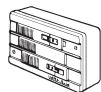
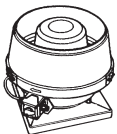

Stock Ref.	D.O.L & starter Stock Ref.	Electronic controller Stock Ref.	Auto transformer Stock Ref.	Air operated Shutters † Stock Ref.	Roof attenuators			*eDemand Controller		
					600mm † Stock Ref.	900mm † Stock Ref.	1200mm † Stock Ref.	Voltage Control Stock Ref.	1/3 Phase Inverter Stock Ref.	3 Phase Inverter Stock Ref.
RMV20014	444744 + 444698	W10303102M	10314103	-	-	-	-	444164	-	-
RMV28014	444744 + 444701	W10303102M	10314103	10517315	10520315	10521315	10522315	444164	-	-
RMV35514	444744 + 444703	*	*	10517315	10520315	10521315	10522315	-	-	-
RMV35534	444744 + 444700	-	10314304	-	-	-	-	444164	-	-
RMV45034	444747 + 444701	*	*	10517400	10520400	10521400	10522400	444166	444177	444172
RMV50034	444747 + 444699	*	*	-	10520500	10521500	10522500	444166	444177	444172
RMV56034	444744 + 444701	*	*	-	-	-	-	444164	-	-
RMV35516	444747 + 444702	W10303102M	10314103	-	-	-	-	-	-	-
RMV35536	444747 + 444700	-	10314301	10517315	10520315	10521315	10522315	444166	444177	444172
RMV45016	444747 + 444704	10303103A	10314103	10517400	10520400	10521400	10522400	-	-	-
RMV45036	444744 + 444702	-	10314304	-	-	-	-	-	-	-
RMV50036	444748 + 444706	*	*	-	10520500	10521500	10522500	-	-	-

† When air operated shutters are used in conjunction with roof attenuators, there must be a minimum spacing of half the attenuator width between them. When an attenuator is located directly below a roof fan a motorised shutter should be used.

* For full range of speed controller options, see Accessories & Controllers Section