

Trakmaster Twin Fan Controller*

The range of intelligent Vent-Axia twin fan controllers has been designed to offer total flexibility and controlled interface with BMS (Building Management Systems) saving installation costs, and providing energy management/night setback facility

ITC - (Trakmaster twin fan control)



Provides automatic changeover on fan failure as well as enabling a manual selection of either fan for duty sharing or test purposes. (BMS compatible via volt free contacts). This controller must have a permanent live supply. Any On/Off switching must be via the sensor connections S1 and SG terminals.

Stock Ref. No. 10314200

RVC - (Remote visual indicator)



Wired in conjunction with either an ITC or ITC-DS controller the RVC can be located up to 100m away using low cost ELV wiring. The compact, single gang RVC ELV (Extra Low Voltage) remote visual controller indicates status of Fan 1 and Fan 2 with status/warning lights. Push button allows Fan 1 and Fan 2 with standby (Off) to be selected.

Stock Ref. No. 10314220

ITC-DS - (Trakmaster twin fan control - Duty sharing)



Incorporates a timing mechanism which operates alternate fans on 12 or 24 hour intervals, thus ensuring the extended life of the fan bearings. The controller also provides automatic changeover on fan failure along with the facility for manual selection of either fan. (BMS compatible via volt free contacts). This controller must have

a permanent live supply. Any On/Off switching must be via the sensor connections S1 and SG terminals.

Stock Ref. No. 10314210

RSC - (Remote setback control)



The RSC multi-speed control system offers 2 speed fan versatility eg. Energy Management for night time setback. Can be used in conjunction with Vent-Axia ITC, ITC-DS controllers using 5 step auto-transformer speed controllers for speed selection. Uses 24V output from ITC controller.

Stock Ref. No. 103 14 230A

Electrical ITC/ITC-D S

Maximum load: 9 amps on single or three phase.

Dimensions

ITC-DS - 103 14 210 OR ITC - 10314200

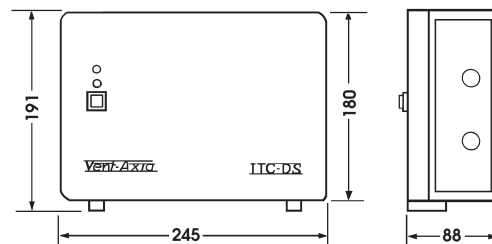

RSC - 103 14 230A

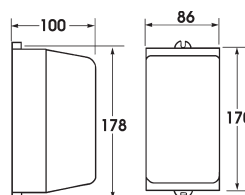

RVC - 10314220

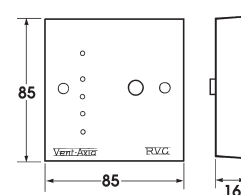

Note: Suitable for mounting with single gang electrical box.

PLEASE NOTE: The ITC Controllers may be used in conjunction with a 5-Step Auto Transformer SPEED CONTROLLER for commissioning purposes to meet the required design criteria.

*For alternative eDemand twin fan controls see Accessories & Controllers Section



Sensors for use with ITC and ITC-DS controls

ThermoSwitch

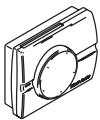

Operates on either a fall or rise in temperature for extraction of excess heat. Range 6°C to 30°C.

Stock Ref. No. 563502B

Ecotronic Humidistat

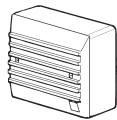

An electronic On/Off humidistat with concealed humidity adjustment 65-90% RH with removable pullcord override. Changeover relay switch.

Stock Ref. No. 563550A

Air Quality Sensor



Automatically reacts to tobacco smoke, smells and toilet odours to trigger the system or switch speed.

Stock Ref. No. 563506B

7-Day TimeSwitch



7-Day timer with analogue display. Override facility. Gives twelve On or Off positions per day.

Stock Ref. 563515

HumidiSwitch

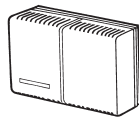

Actuates mechanical humidistat ventilating units on either a rise or fall in humidity. Concealed adjustment. Range 20% to 80% RH.

Stock Ref. No. 563501D

Visionex PIR Detector

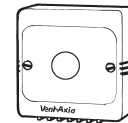

Ceiling mounted movement detector. Adjustable overrun timer 5 to 25 minutes. Fits any UK single gang mounting box. Range of detection up to 10 metres.

220-240Vnce Guideui
Stock Ref. No. 459623A

Connection Layout of ITC And ITC-DS Controller

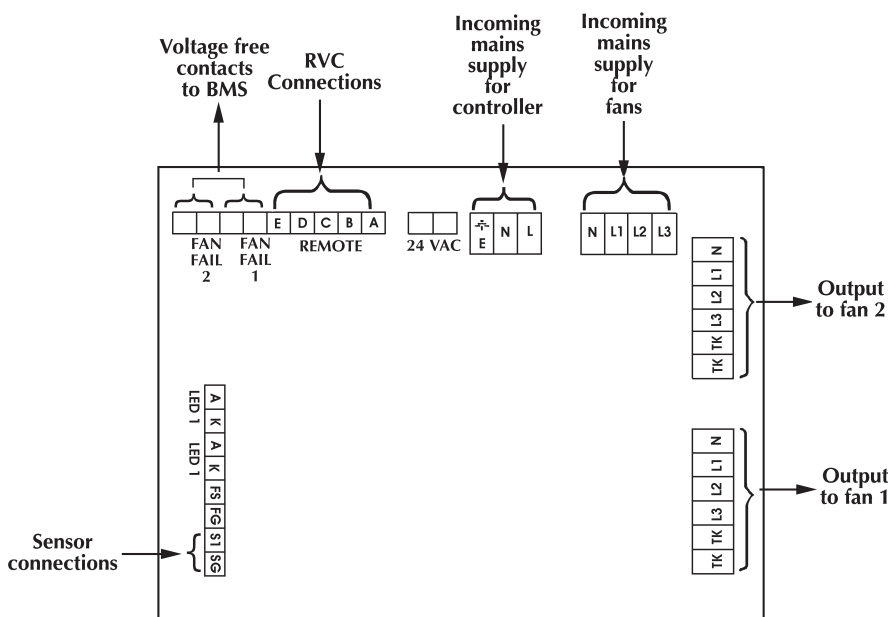

For full wiring information, refer to ITC Fitting & Wiring instructions.