

Lo-Carbon Kinetic® E MVHR Unit



Features & Benefits

- Compact and quiet.
- Light weight for easy installation.
- Easy access filters.
- External condensate connection.
- Compatible with a range of controls: PIR, Humidistat
- Horizontal spigot option.
- Energy saving ECDC motors
- Quiet operation.
- Manufactured in the UK.
- Switched live inputs (Light switch control)

A wholehouse heat recovery system with 92% energy efficiency. An easily accessible heat recovery cube protected by two removable EU3 filters. Two Lo-Carbon Energy Saving EC DC fans ensure long life (typically over double the life of AC motors) and lowest possible energy use. Fully insulated construction with built in condensation drain.

Dimensions (mm)

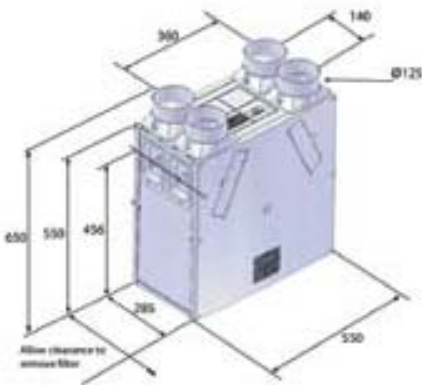

Lo-Carbon Kinetic E meets the latest requirements of the Building Regulations Document F 2010 for wholehouse system ventilation.

The Lo-Carbon Kinetic E model has 2 adjustable speeds, normal and boost. On the front of the unit is the controller that can be used to pre-set the speeds to any required performance, up to 135m³/hr (38l/s) 100pa. Offering 'Close Control' to prevent over ventilating. Acoustically lined - low noise levels from only 20dB(A) @3m.

Left or right hand installation.

Units are supplied as RH version with duct spigots to outside on the right hand side. These can be reversed onsite by simply removing the control panel, rotating the unit 180 degrees and re-attaching the control panel.

Horizontal and vertical spigots:

The combination of spigot options allows installation in confined locations. If vertical and horizontal connection is required on the same outlet/inlet, additional spigots can be supplied.

Control options

There are two LS (Switched Live) inputs allowing the unit to be connected to a number of sensors and controllers such as Vent-Wise, Timespan, Ambient Response Humidistat. One of the LS connections also benefits from a 'delay on' feature which prevents the unit boosting unnecessarily.

Model

Kinetic E
Stock Ref **443303**

Kinetic Spare Filters 2 pack
Stock Ref **441774**

SAP Appendix Q Test Results

Exhaust Terminal Configuration	Total Flow Rate (l/s)	Specific Fan Power (W/l/s)
Kitchen + 1 additional wet room	15.0	0.51
Kitchen + 2 additional wet rooms	21.0	0.58
Kitchen + 3 additional wet room	27.0	0.71

Performance

