

**OPERATION AND
MAINTENANCE
INSTRUCTIONS**

**SINGLE PHASE
TRANSFORMER
SPEED CONTROLLERS**



ROOF UNITS LIMITED

Blackbrook Road, Narrow Boat Way,

Dudley, West Midlands, DY2 0NB

Tel : (01384) 418670

Fax : (01384) 418681

**IMPORTANT – PLEASE READ THESE INSTRUCTIONS FULLY
BEFORE COMMENCING INSTALLATION.**

These instructions refer to the following models: -

SPM5026: 230V a. c. 50Hz Maximum Operating Current: 2.0A

SPM5055: 230V a. c. 50Hz Maximum Operating Current: 4.0A

SPM5070: 230V a. c. 50Hz Maximum Operating Current: 7.0A

SPM5090: 230V a. c. 50Hz Maximum Operating Current: 9.0A

SPM5140: 230V a. c. 50Hz Maximum Operating Current: 14.0A

• **SAFETY**

All electrical installation must be undertaken by a suitably qualified and competent person and must be carried out in accordance with all relevant Statutory Requirements. Please check the details on the unit rating plate to ensure that the correct power supply (Voltage, Frequency, and Phase) is available. Do not use the speed controllers with an incorrect power supply, overheating and failure of the circuit board will occur.

The controller must not be used when the ambient air temperature may exceed 40°C and where it is liable to be subjected to water spray.

• **INSTALLATION**

The controller is suitable for surface mounting only. Remove front cover and ensure backbox is securely fixed to wall in a well-ventilated area. Route supply and load cables through 'Knock-out' holes provided. If the controller is mounted on a conductive (metal) surface, that surface must be earthed.

• **GENERAL WIRING**

Warning:- The Control Equipment Must Be Isolated From The Power Supply During Installation And / Or Maintenance. The Equipment Must Be Earthed.

Connect the power supply from the local isolator (via any appropriate controls if fitted) and the load supply to the backbox via an appropriate cable gland. Refer to the wiring diagram and select the appropriate connections for the controller and / or other devices as being installed. Ensure that all earth connections have been made.

After completing and checking the connections to the controller replace the front cover ensuring that it is correctly seated in place. Ensure that all cable gland / grommet fixings and lid fixings are tightened correctly to prevent water ingress.

- **CHECK LIST**

- 1) Are all links and wiring complete (refer to wiring diagram)?
- 2) Are all fixings secured?
- 3) Are all protective circuit devices fitted and wired correctly?
- 4) Are all covers and gland fittings secure?
- 5) Are all earth connections secured?
- 6) Check that no hazard exists for persons in the locality of the fan.
- 7) Check that the current (amps) taken by the fan does not exceed the current shown on the rating plate of both fan and controller.

- **OPERATION**

Switch on the mains supply. Turn the control Knob from zero to required speed, the power on lamp will illuminate to show operation. Check required rotation of fan and ensure the fan operates correctly.

These controllers are not fitted with a reset function. In the event of fan failure it is possible for the fan to restart without warning. It is the installer's responsibility to provide adequate safety devices to meet the requirements of all statutory safety regulations.

- **RESPONSIBILITY**

Roof Units Limited, as suppliers of the equipment cannot be responsible for the final installation and electrical connection of the product on site. We have made reasonable effort to offer guidance and assistance but the installer and electrical contractor on site have a responsibility for ensuring the equipment is safely and securely installed and electrically / mechanically safe in accordance with statutory requirements.

The controllers are supplied as a component to be incorporated into a ventilation system. The final complete system installation that includes the controllers MUST meet all relevant directives.

- **GUIDELINES FOR EMC COMPATIBLE INSTALLATIONS**

Compliance with EMC directives is only ensured when the product has been correctly installed.

Safety Earthing must always take precedence over additional earthing required to maintain EMC compliance.

Care must be taken when installing cables; those used for inductive loads must be separated from more sensitive cables, e.g. Sensor Cables, Personal Computers and CCTV.

These controllers have been designed to operate without the need to use shielded cables between the controller and fan. There may be instances where shielded cable is required, e.g. when sensor cables are in close proximity, and under these circumstances the shielding should be bonded at both ends.

WIRING DETAILS

MOTORS WITH EXTERNAL THERMAL CONTACTS

230V 1PH 50Hz SUPPLY

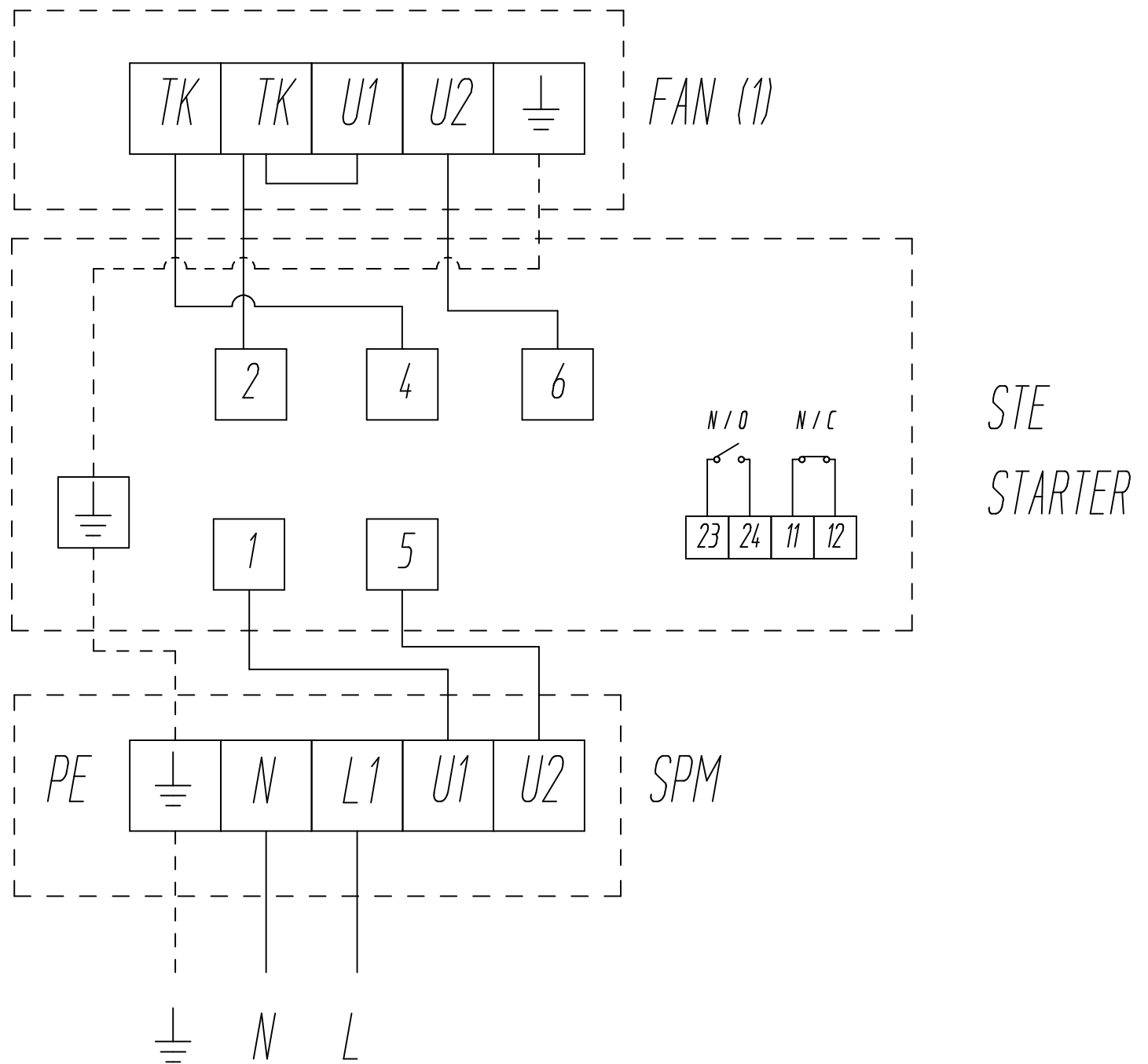
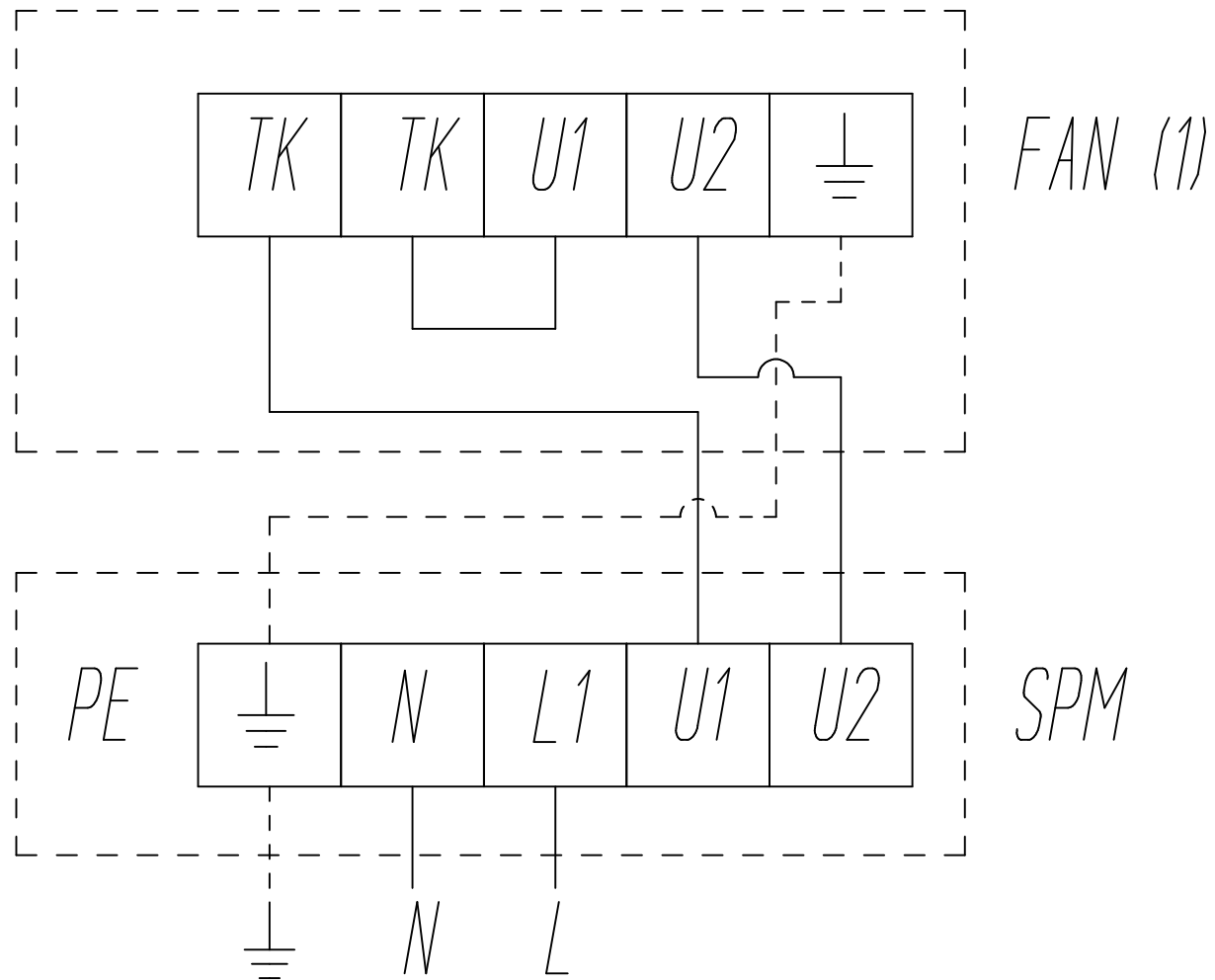

(1) Fan Terminals May Vary With Model. Refer To Instructions Supplied With The Fan For Correct Terminations.

All Wiring Must Be Installed By A Suitably Qualified And Competent Person In Accordance With Current Regulations.

WIRING DETAILS

MOTORS WITHOUT EXTERNAL THERMAL CONTACTS

230V 1PH 50Hz SUPPLY

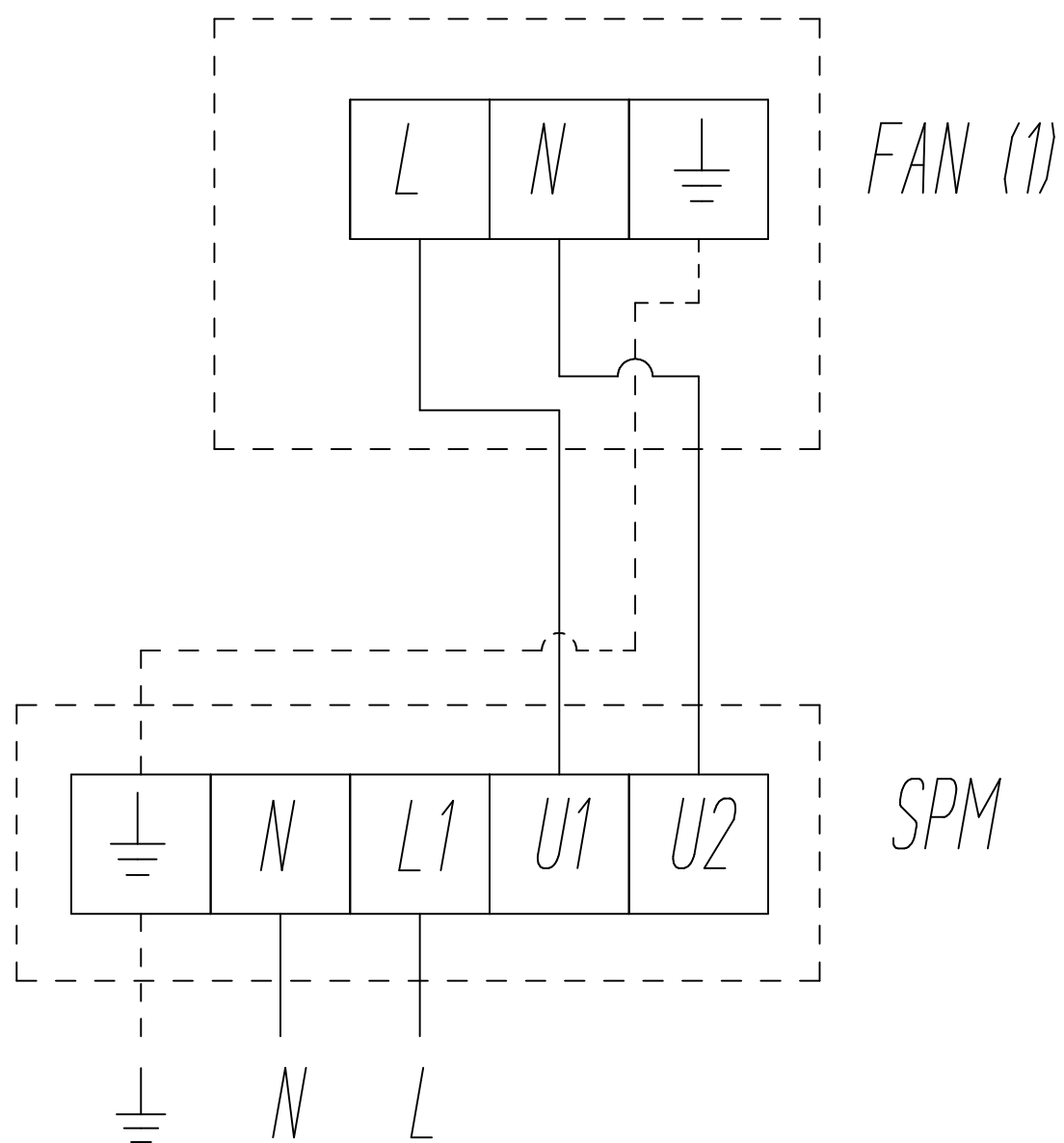

(1) Fan Terminals May Vary With Model. Refer To Instructions Supplied With The Fan For Correct Terminations.

All Wiring Must Be Installed By A Suitably Qualified And Competent Person In Accordance With Current Regulations.

Roof Units Limited Guarantee

Roof Units will, free of charge, within a period of 1 year from the date of dispatch from their works repair or at its option replace any controllers which are proved to their reasonable satisfaction to be defective in material or workmanship unless:-

- 1) The goods have been altered in any way
- 2) The goods have been improperly installed or connected or
- 3) The buyer has failed to notify Roof Units of any defect or suspected defect within 14 days of the same coming to the knowledge of the buyer.
- 4) Any goods replaced will belong to Roof Units. Any repaired or replacement goods will be guaranteed on these terms for the unexpired portion of the 1 year period.
- 5) Otherwise subject to our standard terms and conditions.

The goods returned to Roof Units works carriage paid to enable examination, repair or replacement.

Roof Units Limited reserves the right to alter specification without notice.



ROOF UNITS LIMITED

Blackbrook Road, Narrow Boat Way,

Dudley, West Midlands, DY2 0NB

Tel : +44 (01384) 418670

Fax : +44 (01384) 418681

OM/SPM/10/00/B