

Slimpak

In-Line Twin Duct Fans

Wiring Diagrams 230V 1PH 50Hz Supply

SINGLE PHASE FAN CONNECTED TO AN ITC CONTROLLER & OPTIONAL EXTERNAL SENSOR/SENSORS WIRING DIAGRAM

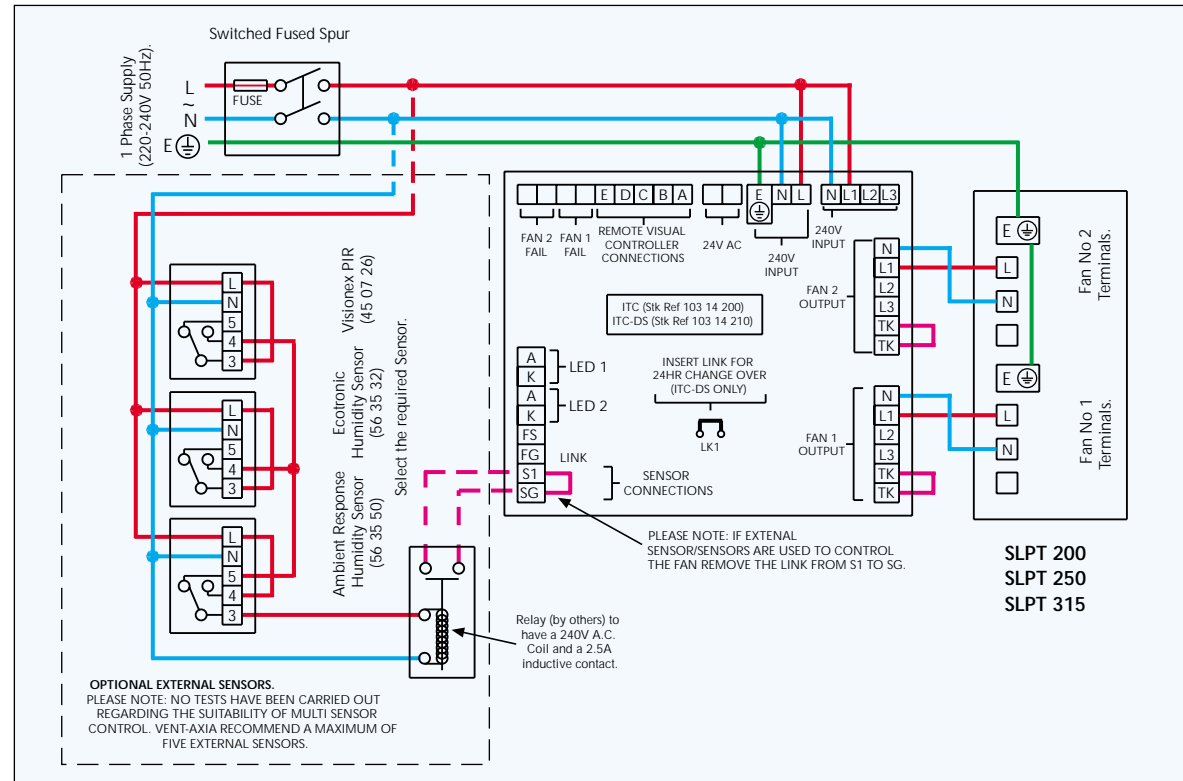

THREE PHASE FAN CONNECTED TO AN ITC CONTROLLER & OPTIONAL EXTERNAL SENSOR WIRING DIAGRAM

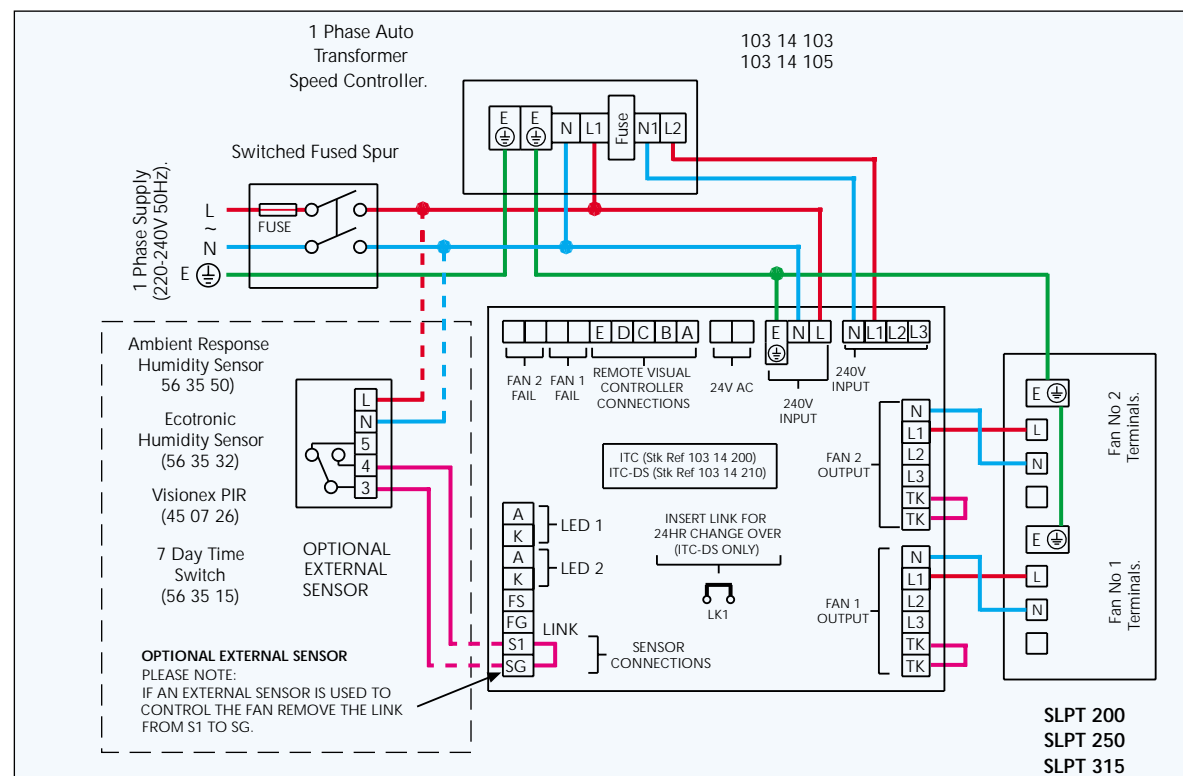

In-Line Twin Duct Fans

Wiring Diagrams 230V 1PH 50Hz Supply

SINGLE PHASE FAN CONNECTED TO A D.O.L. STARTER, WIRED FOR SIMULTANEOUS RUNNING

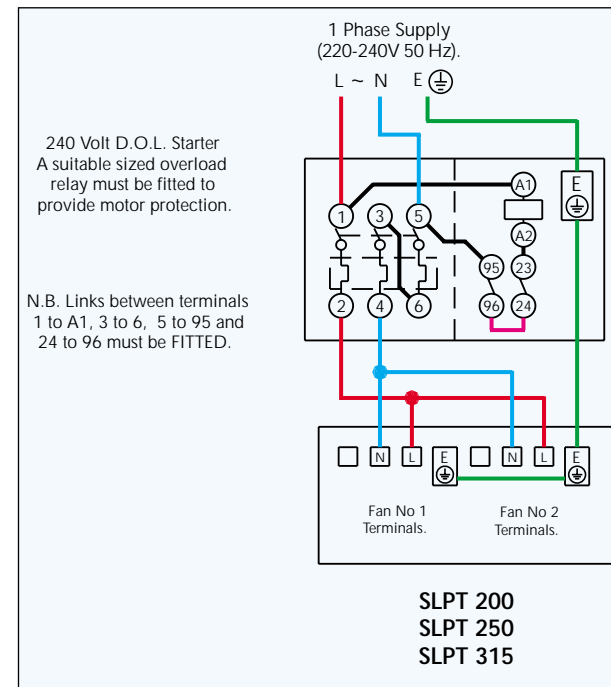

SINGLE PHASE FAN CONNECTED TO AN AUTO TRANSFORMER SPEED, WIRED FOR SIMULTANEOUS RUNNING

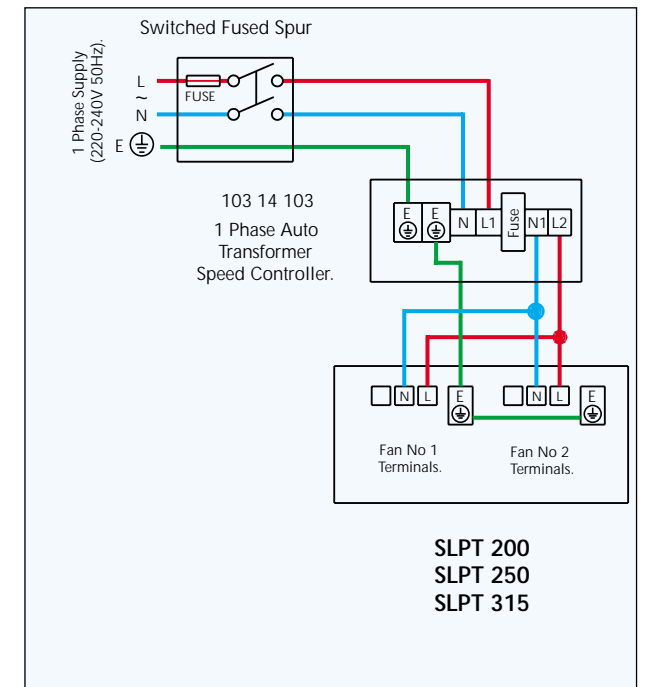

Dimensions (mm)

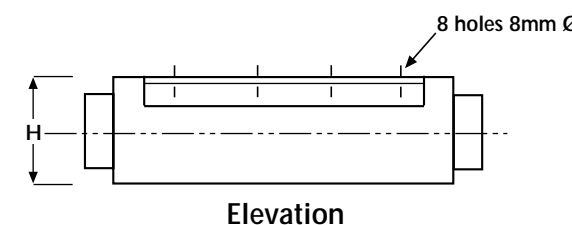
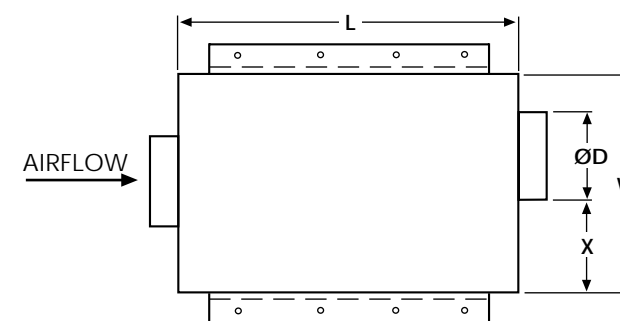

Duct Dia.	Stock Ref. No.	L	W	H	ØD	X	Weight Kg
200	SLPT200	760	490	235	200	205	20
250	SLPT250	865	590	285	250	233	32
315	SLPT315	955	650	350	315	240	39