

Lo-Carbon Quadra®

"One Fan fits all" Centrifugal Fan



Features and Benefits

- Single fan for use in toilets, bathrooms, utility rooms and kitchens.
- Meets Building Regulations for intermittent or continuous use.
- Guaranteed installed performance.
- 100mm circular spigot for easy installation and replacement of any existing fan.
- Filterless technology and maintenance free.
- LoWatt motors offering 90% energy savings and long life.
- Motor cassette cartridge for simple replacement.
- Suitable for flush or surface mounting.
- 5 Year Motor Guarantee
- **IPX4** rated

Ventilation for any room

The Lo-Carbon Quadra offers a single fan suitable for surface or flush mounting (when used with the flush mounting kit) in any room. Speeds selectable at installation enable Quadra to be used in toilets, bathrooms, utility rooms or kitchens to comply with either continuous or intermittent Building regulations (Document F) requirements. Low speed selectable between 6, 9 and 12l/s and high between 15, 30 and 60l/s all with through the wall or two ducted selections to ensure installed performance is met.

Low maintenance design

The unique filterless design provides a maintenance free fan with the additional benefit of a cartridge system in the unlikely event of a motor failure. This ensures that it offers the easiest installation and replacement available. Less waste also means less landfill, improving the products

carbon footprint and sustainability.

Discrete

With discrete aesthetics and low noise levels due to an accurately balanced impeller, it is also one of the most unobtrusive centrifugal kitchen fans available. The front cover design also provides no area for dirt to build up so it stays looking better for longer.

Models

Quadra TP (Timer/pullcord) DOM

Dual speed continuous running or intermittent to high speed. High speed via pullcord (on/off) or switch live (with overrun timer)

Stock Ref
439251

Quadra HTP DOM

Dual speed continuous running or intermittent to high speed. High speed via

integral pullcord (on/off), integral adjustable humidity sensor or switch live (with overrun timer)

Stock Ref
439181

Quadra TM DOM

Dual speed continuous running or intermittent to high speed. High speed via integral PIR sensor or switch live (both with overrun timer)

Stock Ref
439253

Flush mounting Kit DOM

Stock Ref
439256

Filter DOM

Stock Ref
439927

Decoration Frame DOM

Stock Ref
442551

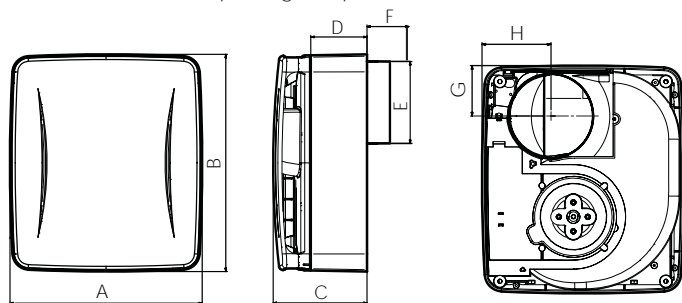

| A | B | C | D | E | F | G | H |
|-----|-----|-----|----|----|----|----|----|
| 230 | 260 | 112 | 67 | 98 | 27 | 58 | 79 |

Performance

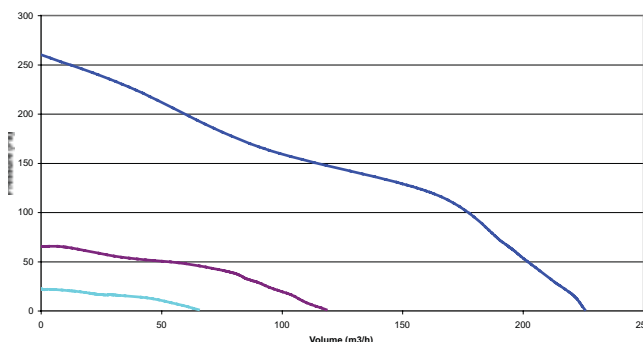

Performance

| Model | Stock Ref Number | Extract Performance High | | Extract Performance Low | | Power High Watts | Power Low Watts | Sound dB(A) @ 3m | | SFP @Pa |
|------------|------------------|--------------------------|-----|-------------------------|-----|------------------|-----------------|------------------|-----|---------|
| | | m³/h | l/s | m³/h | l/s | | | High | Low | |
| Quadra TP | 439251 | 216 | 60 | 22 | 6 | 35.7 | 3.8 | 50 | 20 | 0.26 |
| Quadra HTP | 439181 | 216 | 60 | 22 | 6 | 35.7 | 3.8 | 50 | 20 | 0.26 |
| Quadra TM | 439253 | 216 | 60 | 22 | 6 | 35.7 | 3.8 | 50 | 20 | 0.26 |

*Tested in through the wall installation

Wall/Window kits (see page 89)