

Integra® Plus

Ducted MVHR Unit



Features & Benefits

- Powered heat recovery unit for larger residential or commercial applications
- Up to 70% heat recovery
- Low power consumption
- Effective condensation control
- 3 speed control

Easy Installation

The Vent-Axia Integra Plus is designed for mounting in ceiling voids, lofts, above a suspended ceiling or vertical wall mounting. Four 150mm spigots are provided for simple connection to insulated flexible or rigid ventilation ducting. The unit comes complete with a 22mm condensate outlet.

Model

Stock Ref
437666

Performance

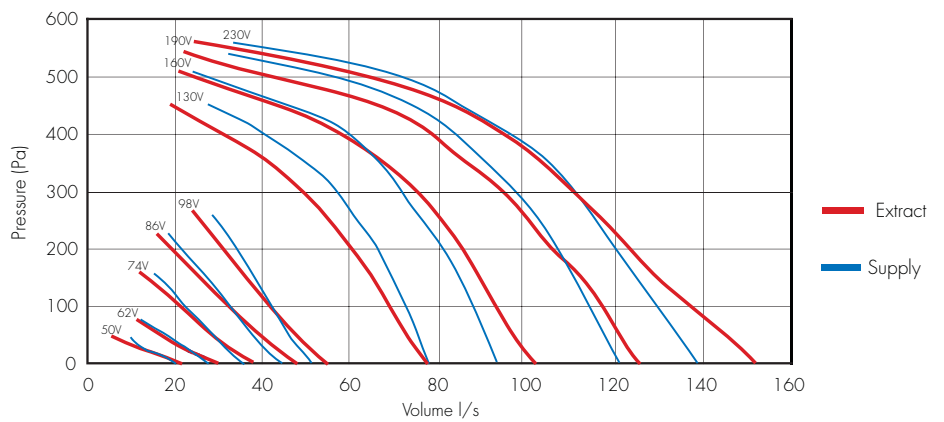

Units supplied complete with transformer

Motor Speed	1	2	3	4	5	6	7	8	9
Volume l/s (FID)	19.4	29.2	36.1	44.4	50	13.9	91.7	113.9	127.8

Controllers & Sensors

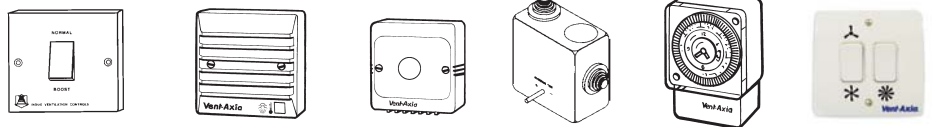

Trickle Boost Switch	Ambient Response Humidistat	Visionex PIR	TIM2	7 Day TimeSwitch	3 Position Switch
455213	563550A	459623A	370346	563515	5108454

Dimensions (mm)

Weight : 15.5kg fan box, 5kg controller

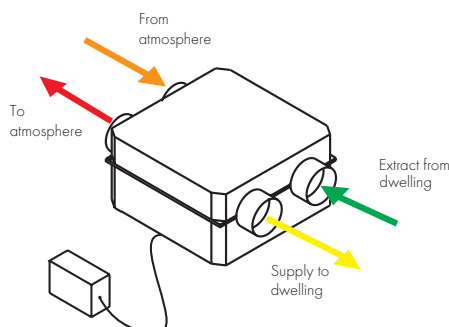
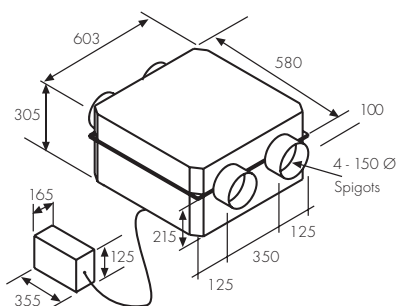

Power Consumption and noise level

			dB(A) @ 3m
Speed 1	30W	50V	19.2
Speed 2	45W	62V	19.5
Speed 3	66W	74V	20.9
Speed 4	85W	86V	21.9
Speed 5	115W	98V	24.5
Speed 6	188W	130V	30.8
Speed 7	262W	160V	34.3
Speed 8	330W	190V	36.9
Speed 9	425W	230V	39.2