

HR200V

Ducted MVHR Unit



Features & Benefits

- Powered heat recovery module for smaller commercial applications.
- Up to 70% heat recovery.
- With 150mm duct connection.
- Extremely quiet on low speeds.
- Low power consumption.
- Washable heat exchanger.
- Pre-wired to a flexible cable.

A ducted heat recovery unit for internal rooms. Self-contained and includes two mixed flow speed controllable fans. Using a high performance, polymeric heat exchange cube together with two power fans, the HR200V can boast a temperature efficiency of up to 70%. Low speed for trickle ventilation mode.

Specially designed to provide ventilation for small internal rooms in commercial, educational and leisure applications. Ventilation is achieved by using nominal 150mm diameter ducting. The unit includes two mixed flow speed controllable fans plus a high efficiency polymeric heat exchanger.

Models

HR200V
Stock Ref
14120010

Transformer 150VA
Stock Ref
563538A

Dimensions (mm)

Weight : 15.5kg fan box, 5kg controller

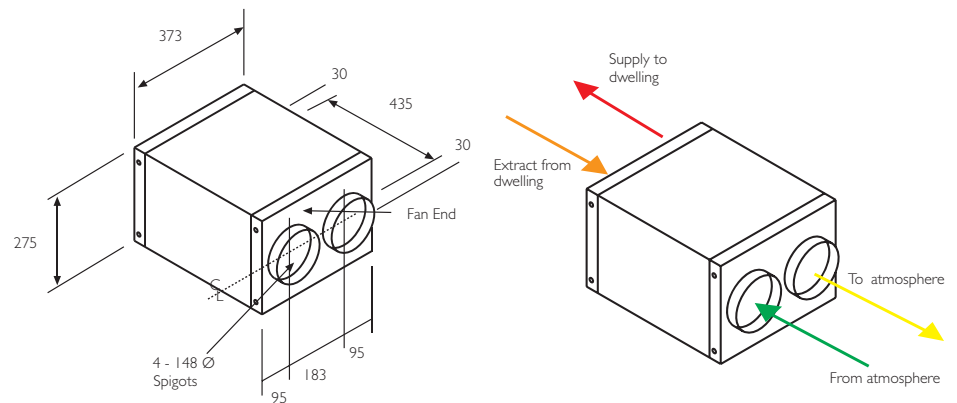

Performance

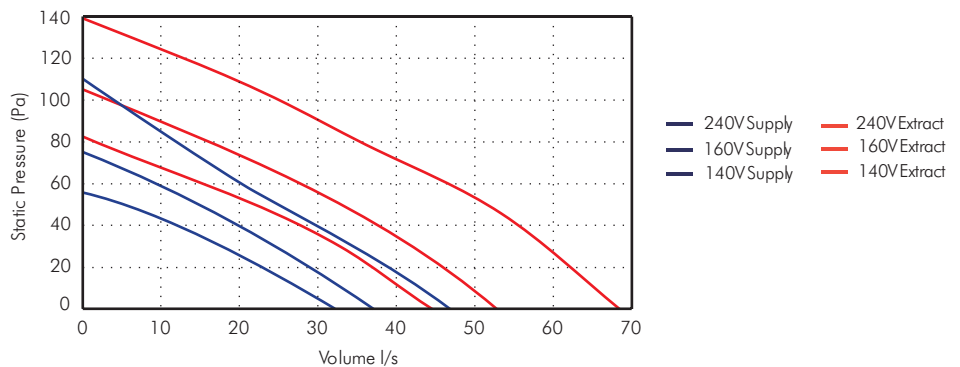

HR200V to be used with a 150VA Transformer for maximum controllability

Motor Speed	1	2	3
Voltage	140	160	240
Watts	51.5	60	110
Volume l/s (FID) Supply	48.3	55.8	70.3
Extract	241	286	371