

HR100R/RS

Ducted MVHR Unit



Features & Benefits

- Controls condensation and odours - saves energy
- Eliminates mould growth
- Up to 70% Heat Recovery
- Extremely quiet operation
- Two speed settings
- Meets new Building Regulations for bathrooms and toilets

The HR100R and HR100RS are ideal for single bedroom/bathroom applications such as hotel rooms, nursing homes and residential care homes.

The HR100R features top access and is ideal for loft installations.

The HR100RS features bottom access and is ideal for installation on the ceiling slab above a suspended ceiling.

The HR100R/RS is a self-contained heat recovery unit for mounting in lofts and suspended ceilings. The unit is supplied without controls to allow for the unit to be tailored to suit the individual requirements.

Compatible with standard 100mm ducting for connection to internal grilles and external cowl.

The unit comes fitted with a single 2-speed motor, and provides continuous low volume ventilation with a boost option. A variety of control devices are available for manual or automatic speed control.

An integral heat exchanger transfers heat from the outgoing stale air to the fresh air supply, raising the supply air temperature whilst at the same time reducing its relative humidity.

Up to 66m³/h FID capacity. The unit provides superior control of condensation and odours, ideal for bathrooms or small internal rooms.

Models

HR100R

Top access - ideal in loft installations.

Stock Ref
370377

HR100RS

Bottom access - ideal for suspended ceilings.

Stock Ref
435004

Performance

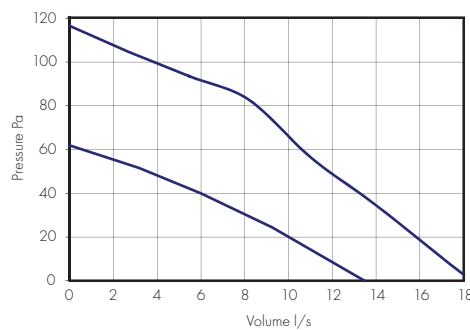

Dimensions (mm)

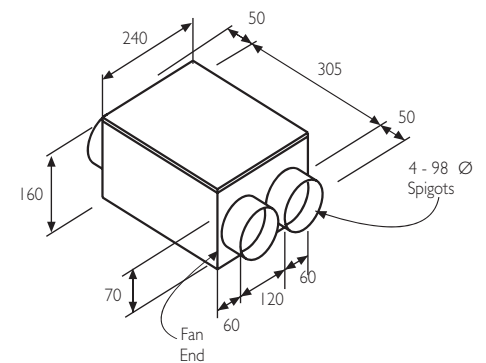

HR100RS version

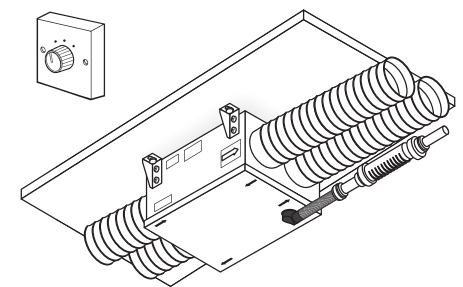

Performance

Model	Weight Kg	Extract Perf. l/s		Watts		dB(A) @ 3m*	
		Boost	Trickle	Boost	Trickle	Boost	Trickle
HR100R	5.6	18.3	13.6	29	19	30	20
HR100RS	5.6	18.3	13.6	29	19	30	20

Mains electrical supply: 230V/50Hz