

Galaxy™ Roof Mounting Belt Driven Twin Fans (GRB)

Features and Benefits

- **Roof mounting, fully weatherproofed belt driven, low silhouette twin fan**
- **High quality mill finished aluminium casing**
- **Anodised aluminium discharge louvre**
- **Optional inlet spigot position**
- **Pre-wired IP65 Service Isolator**
- **Motor Insulation Class 'F'**
- **Maximum operating temperature 40°C**
- **Manufacture controlled to BS EN ISO 9001**
- **Performance tested to BS 848 Part 1 & 2**
- **2 Year Guarantee**

The GRB Galaxy Roof Mounting Belt Driven Twin fan range is a high performance, run and standby twin fan. Designed to be controlled in-conjunction with Vent-Axia Trakmaster twin fan controller range, the total package offers the end user flexibility when interfaced with or without a (BMS) Building Management Systems, such as: manual selection; 12/24hr auto changeover ensuring the extended life of the fan and motor.

The unit casing is manufactured from mill finished aluminium fitted with discharge aluminium weather louvre with bird mesh as standard. Assembly is controlled to BS EN ISO 9001.

Individual gravity return shutters are fitted as standard to prevent air re-circulation through the standby fan or the system during shut down periods. Galaxy Roof Mounting Fans are only suitable for horizontal mounting. When

installed on a shallow pitch roof a special upstand will be needed to compensate for the angular difference – to be manufactured by others.

To meet COSHH requirements, double pole service isolator switches are fitted and pre-wired from the fans and mounted to the outer casing to reduce installation time and cost. Access to the fan section is via an easily removed top access panel for cleaning and maintenance during shut down periods.

The Galaxy range is available in four models with extract performance ranging from 0.02m³/s up to 2.5m³/s (720m³/h to 9000m³/h), with pressure characteristics of up to 400Pa. All models are supplied with inlet spigots on the underside of the unit casing and a discharge anodised aluminium weather louvre.

Fan/Motor Assembly

Galaxy GRB belt driven fans are double inlet double width, forward curved centrifugal fans belt driven by totally enclosed fan ventilated motors, wound to suit 220-240V/1/50HZ or 380-415V/3/50Hz electrical supply. Protected to IP54, against dust and water jets complying with BS EN 60529. Motor insulation is Class F as a minimum, suitable for operating temperatures up to +40°C. The fans and motors are mounted on a steel frame, with anti-vibration mounts between the frame and casing and a flexible connection between the fan scroll and fan plate, minimising vibration. All belt driven Galaxy units are supplied with metric pulleys to ISO 4183 and wedge belts to ISO 4184 and DIN 7753.

Electrical

All Motors are available as either single phase 220-240V 50 Hz capacitor start and run or three phase 380V-415V 50Hz. The service isolator is supplied with all models with 20mm and PG11 entry, protected against dust and water jets from any angle.

Performance

The GRB fan performance is tested in accordance with test BS848 Part 1.

Sound Levels

The Fan sound levels are measured in a reverberant chamber in accordance with BS848 Part 2. Published dB(A) figures are free field sound pressure levels at 3m with spherical propagation at a reference level of 2×10^{-5} Pa (20 micro-Pascal). The inlet and outlet sound power level spectra figures are dB with a reference of 10^{-12} Watts (1 picowatt). To ensure minimum noise levels during speed control, an auto transformer speed control is recommended.

Quality Assurance

Design and manufacture are in accordance with the standard for quality management system BS EN ISO 9001.



Fan Dimensions (mm)

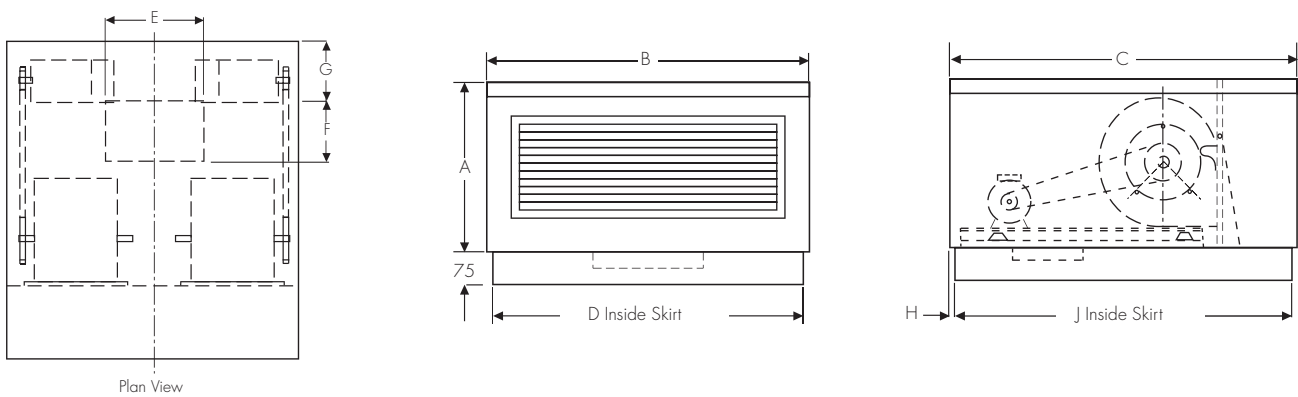

Unit	A	B	C	D	E	F	G	H	J	Weight kg
GRB1	500	900	1100	900	500	250	247	100	900	90
GRB2	600	1150	1175	1120	762	305	150	27.5	1120	120
GRB3	700	1450	1450	1450	900	400	150	-	1450	195
GRB4	800	1550	1450	1550	1000	450	150	-	1450	215

Galaxy™ Roof Mounting Belt Driven Twin Fans (GRB)

Performance Curve

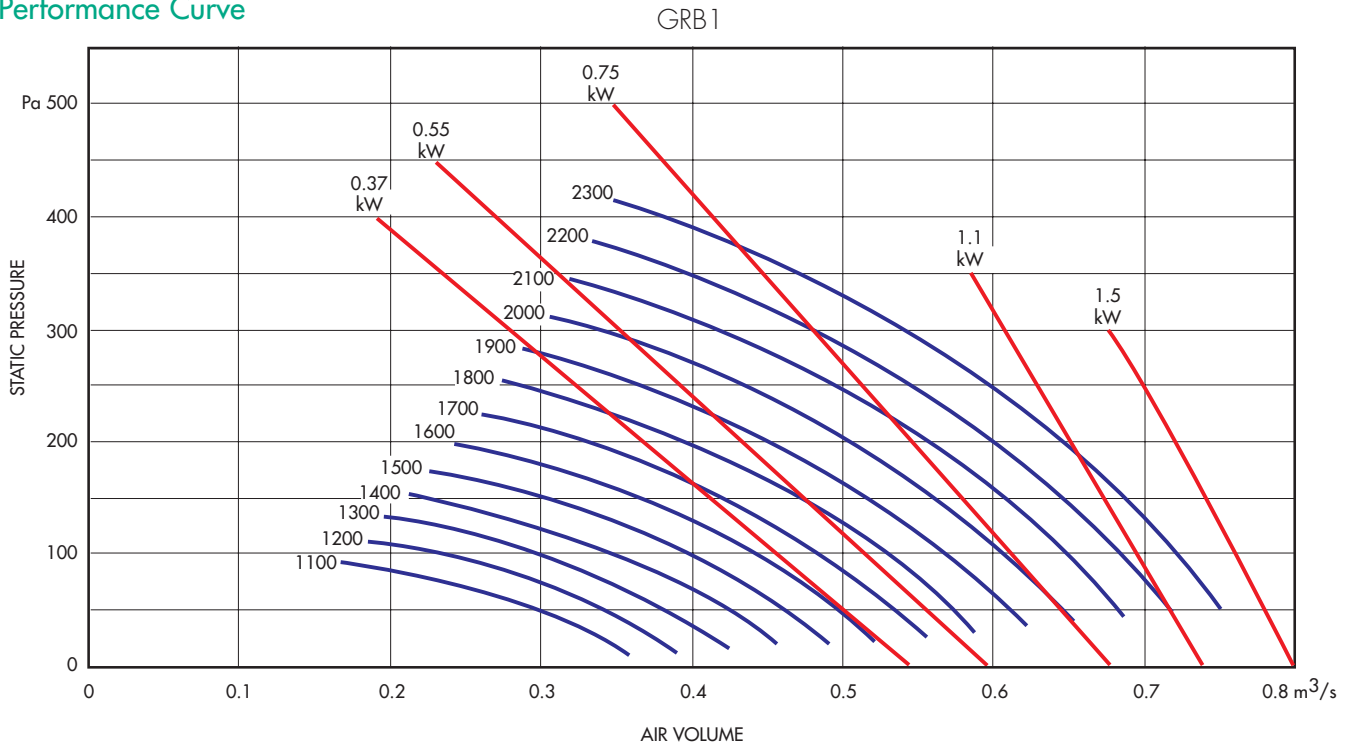

Sound Power Level Spectra dB (re 10⁻¹² Watts)

Unit Size	Fan Speed. R.P.M	Sound Power dBW	Induct Sound Power Levels dBW @ Octave Band Mid Frequency Hz								Sound Pressure dBA @ 3m
			63	125	250	500	1k	2k	4k	8k	
GRB1	1200	71	64	66	65	65	64	61	58	52	50
GRB1	1300	73	66	68	67	67	66	63	60	54	52
GRB1	1400	75	68	70	69	69	68	65	62	56	54
GRB1	1500	76	69	71	70	70	69	66	63	57	55
GRB1	1600	78	71	73	72	72	71	68	65	59	57
GRB1	1700	79	72	74	73	73	72	69	66	60	58
GRB1	1800	80	73	75	74	74	73	70	67	61	59
GRB1	1900	82	75	77	76	76	75	72	69	63	61
GRB1	2000	84	77	79	78	78	77	74	71	65	63
GRB1	2100	86	79	81	80	80	79	76	73	67	65
GRB1	2200	88	81	83	82	82	81	78	75	69	67
GRB1	2300	90	83	85	84	84	83	80	77	71	69

Performance Curve

GRB2

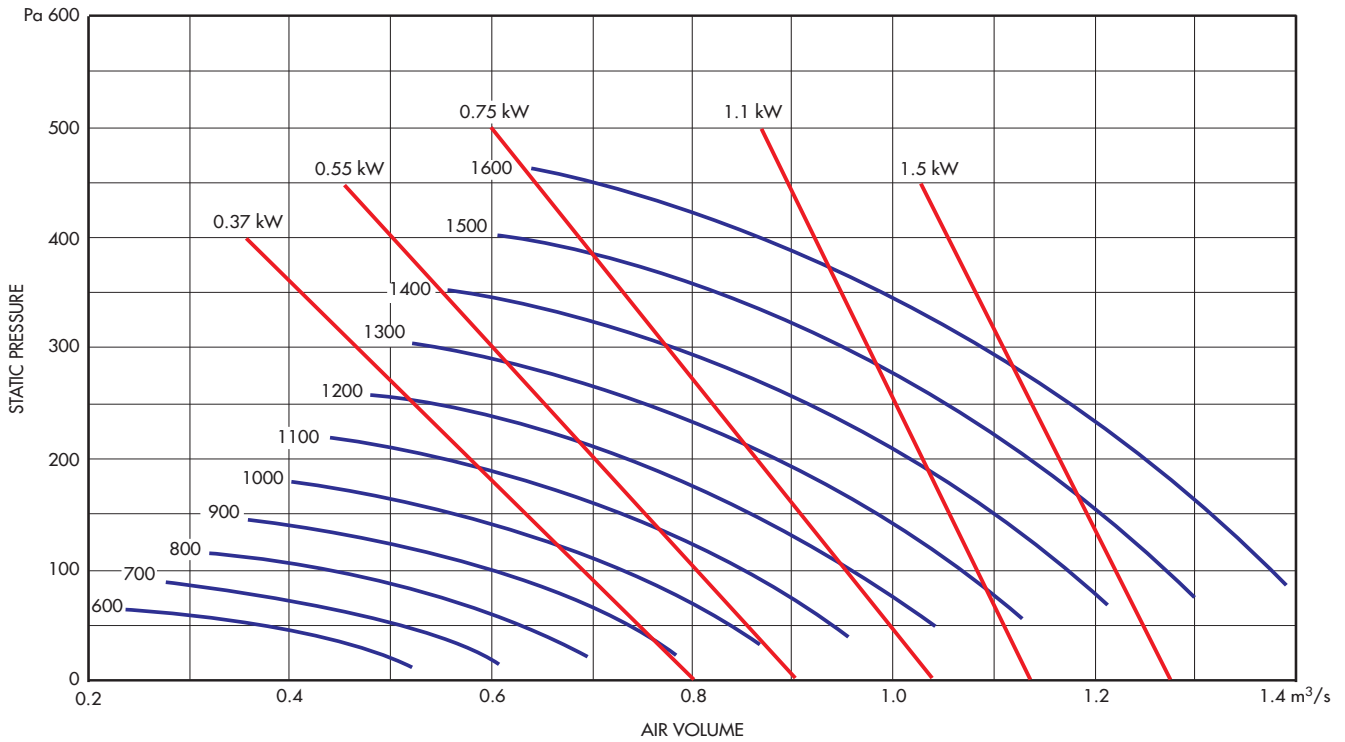

Sound Power Level Spectra dB (re 10⁻¹² Watts)

Unit Size	Fan Speed. R.P.M	Sound Power dBW	Induct Sound Power Levels dBW @ Octave Band Mid Frequency Hz								Sound Pressure dBA @ 3m
			63	125	250	500	1k	2k	4k	8k	
GRB2	600	68	61	63	60	60	58	56	55	48	45
GRB2	700	70	63	65	62	62	60	58	57	50	47
GRB2	800	73	66	68	65	65	63	61	60	53	50
GRB2	900	75	68	70	67	67	65	63	62	55	52
GRB2	1000	77	70	72	69	69	67	65	64	57	54
GRB2	1100	79	72	74	71	71	69	67	66	59	56
GRB2	1200	82	75	77	74	74	72	70	69	62	59
GRB2	1300	84	77	79	76	76	74	72	71	64	61
GRB2	1400	86	79	81	78	78	76	74	73	66	63
GRB2	1500	88	81	83	80	80	78	76	75	68	65
GRB2	1600	90	83	85	82	82	80	78	77	70	67

Galaxy™ Roof Mounting Belt Driven Twin Fans (GRB)

Performance Curve

GRB3

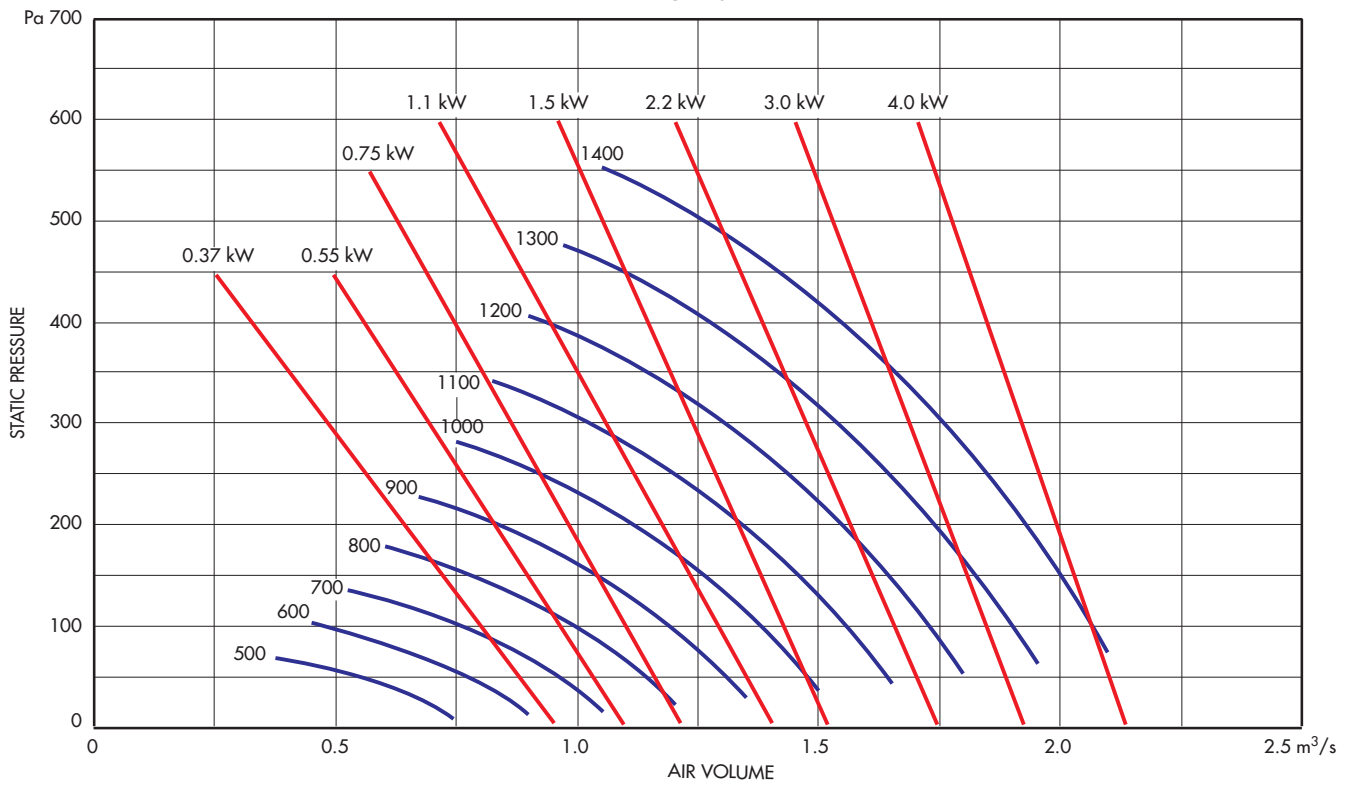

Sound Power Level Spectra dB (re 10⁻¹² Watts)

Unit Size	Fan Speed. R.P.M	Sound Power dBW	Induct Sound Power Levels dBW								Sound Pressure dBA @ 3m
			@ Octave Band Mid Frequency Hz								
			63	125	250	500	1k	2k	4k	8k	
GRB3	500	69	62	63	61	60	63	58	54	51	48
GRB3	600	73	66	67	65	64	67	62	58	55	52
GRB3	700	75	70	69	67	66	69	64	60	57	56
GRB3	800	80	73	74	72	71	74	69	65	62	59
GRB3	900	83	76	77	75	74	77	72	68	65	62
GRB3	1000	86	79	80	78	77	80	75	71	68	65
GRB3	1100	88	81	82	80	79	82	77	73	70	67
GRB3	1200	90	83	84	82	81	84	79	75	72	69
GRB3	1300	92	85	86	84	83	86	81	77	74	71
GRB3	1400	94	87	88	86	85	88	83	79	76	73

Performance Curve

GRB4

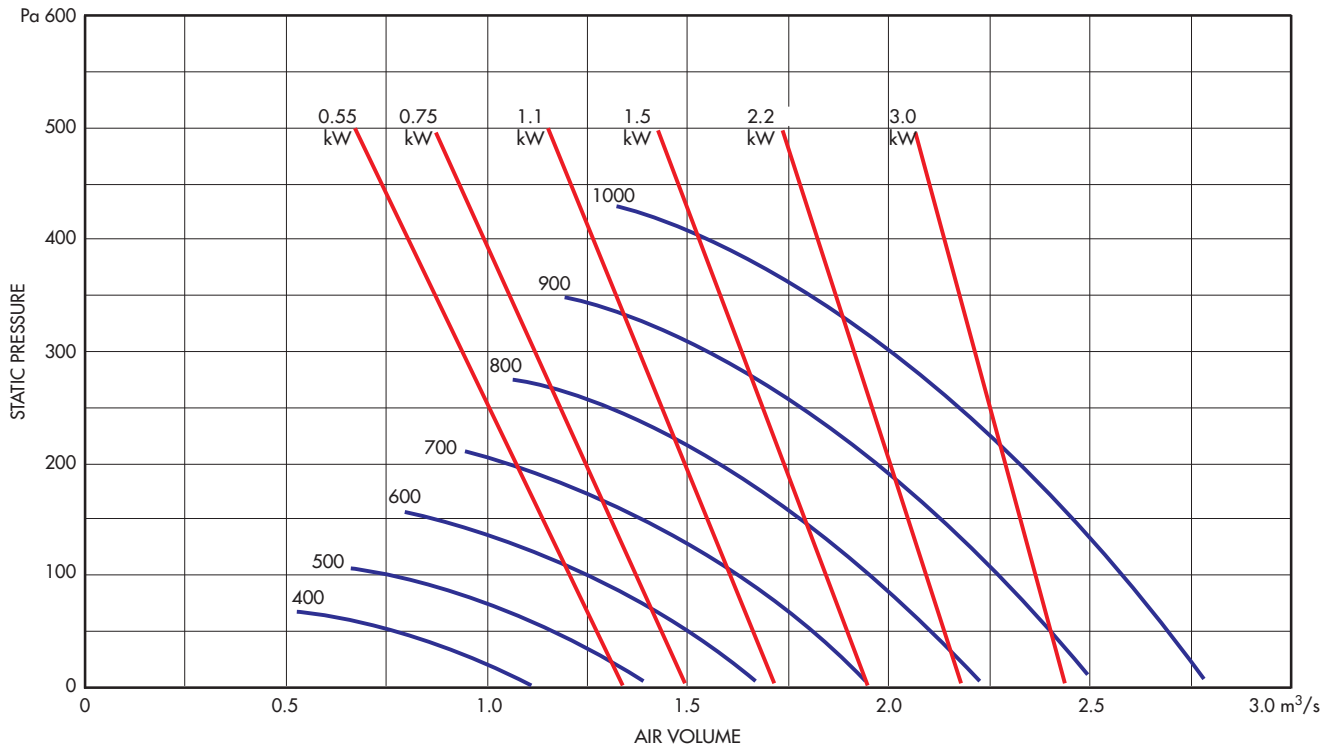

Sound Power Level Spectra dB (re 10⁻¹² Watts)

Unit Size	Fan Speed. R.P.M	Sound Power dBW	Induct Sound Power Levels dBW @ Octave Band Mid Frequency Hz								Sound Pressure dBA @ 3m
			63	125	250	500	1k	2k	4k	8k	
GRB4	400	72	65	66	65	64	61	60	58	53	49
GRB4	500	75	68	69	68	67	64	63	61	56	52
GRB4	600	79	72	73	72	71	68	67	65	60	56
GRB4	700	83	76	77	76	75	72	71	69	64	60
GRB4	800	86	79	80	79	78	75	74	71	67	63
GRB4	900	88	81	82	74	80	77	76	74	69	65
GRB4	1000	90	83	84	83	82	79	78	76	71	67

Galaxy™ Roof Mounting Belt Driven Twin Fans (GRB)

Electrical Data

Motor Rating kW	Motor Nominal Speed r.p.m	400V/3Ph/50Hz	
		F.L.C. Amps	S.C. Amps*
0.37	1400	1.2	4.73
0.55	1400	1.7	8.5
0.75	1400	2.1	9.5
1.1	1400	3.25	13.75
1.5	1400	3.9	20.7
2.2	1400	5.3	28.2
3	1400	7	37.2
4	1400	9.05	52.65

Motor Rating kW	Motor Nominal Speed r.p.m	230V/1Ph/50Hz	
		F.L.C. Amps	S.C. Amps*
0.37	1400	2.7	14
0.55	1400	3.6	18
0.75	1400	5	25
1.1	1400	7	35
1.5	1400	10	50

* D.O.L. Start
 FLC = Full load current
 SC = Starting current

Accessories Dimensions (mm)

Kerb Detail Dimensions (mm)

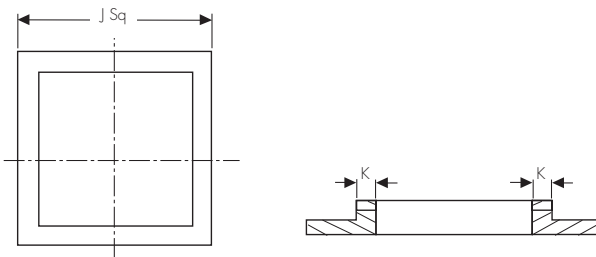

Unit	J	K
GRB1	890	75
GRB2	1110	100
GRB3	1440	100
GRB4	1440	100

Accessories

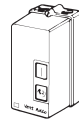
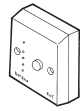
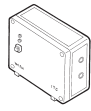
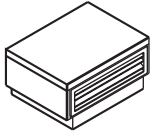

Standard Unit Stock Ref. No.	Insulated Unit Stock Ref. No.	KW	**ITC Man/Auto Changeover Controller Stock Ref.	**ITC-DS 12/24hr Auto Changeover Controller Stock Ref.	RVC Remote Visual Indicator Stock Ref.	240V-1ph Supply DOL starter & 240V Overload Stock Ref.	415V-3ph Supply DOL starter & 415V Overload Stock Ref.	End Inlet Stock Ref.
GRB1	GRBI1	0.37	10314200	10314210	10314220	10311240A + 10312050A	10311415A + 10312015A	EI
GRB1	GRBI1	0.55	10314200	10314210	10314220	10311240A + 10312075A	10311415A + 10312023A	EI
GRB1	GRBI1	0.75	10314200	10314210	10314220	10311240A + 10312075A	10311415A + 10312023A	EI
GRB1	GRBI1	1.1	10314200	10314210	10314220	10311240A + 10312100A	10311415A + 10312050A	EI
GRB2	GRBI2	0.37	10314200	10314210	10314220	10311240A + 10312050A	10311415A + 10312015A	EI
GRB2	GRBI2	0.55	10314200	10314210	10314220	10311240A + 10312075A	10311415A + 10312023A	EI
GRB2	GRBI2	0.75	10314200	10314210	10314220	10311240A + 10312075A	10311415A + 10312033A	EI
GRB2	GRBI2	1.1	10314200	10314210	10314220	10311240A + 10312100A	10311415A + 10312050A	EI
GRB2	GRBI2	1.5	*	-	-	10311240A + 10312150A	10311415A + 10312050A	EI
GRB3	GRBI3	0.37	10314200	10314210	10314220	10311240A + 10312050A	10311415A + 10312015A	EI
GRB3	GRBI3	0.55	10314200	10314210	10314220	10311240A + 10312075A	10311415A + 10312023A	EI
GRB3	GRBI3	0.75	10314200	10314210	10314220	10311240A + 10312075A	10311415A + 10312033A	EI
GRB3	GRBI3	1.1	10314200	10314210	10314220	10311240A + 10312100A	10311415A + 10312050A	EI
GRB3	GRBI3	1.5	*	-	-	10311240A + 10312150A	10311415A + 10312050A	EI
GRB3	GRBI3	2.2	*	-	-	-	10311415A + 10312075A	EI
GRB3	GRBI3	3	*	-	-	-	10311415A + 10312100A	EI
GRB3	GRBI3	4	*	-	-	-	10311415A + 10312150A	EI
GRB4	GRBI4	0.55	10314200	10314210	10314220	10311240A + 10312075A	10311415A + 10312023A	EI
GRB4	GRBI4	0.75	10314200	10314210	10314220	10311240A + 10312075A	10311415A + 10312023A	EI
GRB4	GRBI4	1.1	10314200	10314210	10314220	10311240A + 10312100A	10311415A + 10312050A	EI
GRB4	GRBI4	1.5	*	-	-	10311240A + 10312150A	10311415A + 10312050A	EI
GRB4	GRBI4	2.2	*	-	-	-	10311415A + 10312075A	EI
GRB4	GRBI4	3	*	-	-	-	10311415A + 10312100A	EI
GRB4	GRBI4	4	*	-	-	-	10311415A + 10312150A	EI

NOTE: Units include anti vibration mounts and flexible connections internally, as standard.

* For relevant 1 phase or 3 phase manual/auto changeover controller, see current price list

**Not suitable for use with eDemand controllers. For compatible changeover panel, see Accessories and Controllers Section