

Centra

CONTINUOUS EXTRACT FAN

Installation and Wiring Instructions

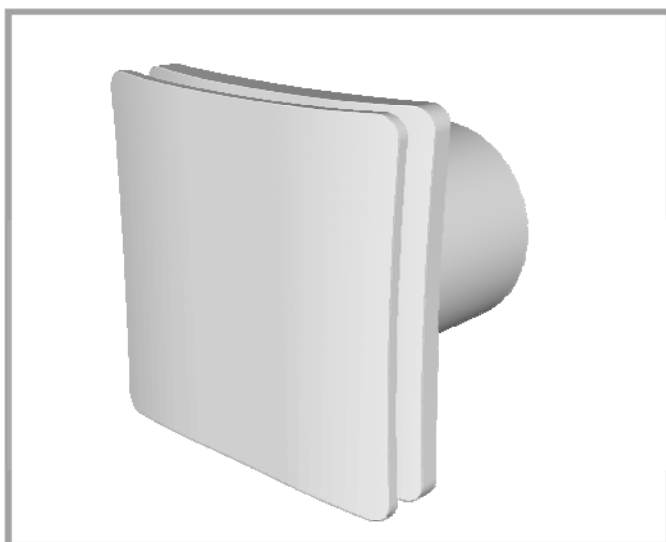

Stock Ref. N°
44 17 82

220-240V~50Hz

Vent-Axia[®]

PLEASE READ INSTRUCTIONS IN CONJUNCTION WITH ILLUSTRATIONS.
PLEASE SAVE THESE INSTRUCTIONS.

IPX4
CE

Installation and Wiring Instructions for the Centra Range of Extractor Fans.



IMPORTANT: READ THESE INSTRUCTIONS BEFORE COMMENCING THE INSTALLATION

DO NOT install this product in areas where the following may be present or occur:

- Excessive oil or a grease laden atmosphere.
- Corrosive or flammable gases, liquids or vapours.
- Ambient temperatures higher than 40°C or less than -5°C.
- Possible obstructions which would hinder the access or removal of the Fan.

SAFETY AND GUIDANCE NOTES

- A. All wiring to be in accordance with the current I.E.E. Regulations, or the appropriate standards of your country and **MUST** be installed by a suitably qualified person.
- B. The Fan should be provided with a local isolator switch capable of disconnecting all poles, having a contact separation of at least 3mm.
- C. Ensure that the mains supply (Voltage, Frequency, and Phase) complies with the rating label.
- D. The Fan should only be used in conjunction with the appropriate Vent-Axia products.
- E. The fan should only be used in conjunction with fixed wiring.
- F. When the Fan is used to remove air from a room containing a fuel-burning appliance, ensure that the air replacement is adequate for both the fan and the fuel-burning appliance.
- G. The Fan should not be used where it is liable to be subject to direct water spray for prolonged periods of time.
- H. Where ducted Fans are used to handle moisture-laden air, a condensation trap should be fitted. Horizontal ducts should be arranged to slope slightly downwards away from the Fan.
- I. This appliance is not intended for use by young children or infirm persons without supervision.
- J. Young children should be supervised to ensure that they do not play with the appliance.

DESCRIPTION

The Centra 100mm fan is a continuously running extract fan for kitchens, utility rooms, bathrooms and toilets.

The integral digital air velocity sensor will monitor the airflow and maintain the preset extract flow rate of either 6l/s, 9l/s or 15l/s, minimising energy use and noise (see Section C-Setup for more information).

Long life ball bearing DC motor with anti-vibration mounts provides virtually zero noise transmission into plasterboard/panels for silent operation.

The fan can be wall or panel/ceiling mounted.

ACCESSORIES (not supplied)

WALL FITTING KIT

A range of white (stock ref. 254102) or brown (stock ref. 254100) 100mm wall kits are available for installing into most walls using telescopic liners supplied.

A. INSTALLATION

IMPORTANT: The fan should only be used in conjunction with fixed wiring.

PANEL/CEILING MOUNTING

1. For panel/ceiling mounting the fan should be installed into a closed duct system of at least 1.2m long or protected by an exterior air grille that must comply with the standard requirements of your country to prevent access to the fans impeller.
2. Cut a 105mm diameter hole.
3. Loosen the screw at the bottom of the grille and remove the front grille. Mark the screw centres through the holes in the fan back plate. Drill, plug and screw into position.
4. Attach ducting as required for the installation.
5. Wire the fan as described in Section B-Wiring. Adjust any settings as required (see Section C-Setup).
6. Replace the grille and tighten the retaining screw.
7. After installation, ensure impeller rotates freely.

WALL MOUNTING

1. For wall mounting cut a 117mm diameter hole through the wall and insert the wall sleeve. Slope the sleeve slightly downwards away from the fan. Cut to length and cement both ends into position flush with the wall faces.
2. Loosen the screw in the bottom of the grille and remove the front grille. Mark the screw centres through the holes in the fan back plate. Drill, plug and screw into position.
3. Fix exterior grille into position with the louvres positioned downwards. (Note:- The grille must comply with the standard requirements of your country to prevent access to the fans impeller).
4. Wire the fan as described in Section B-Wiring. Adjust any settings as required (see Section C-Setup).
5. Replace the grille and tighten the retaining screw.
6. After installation, ensure impeller rotates freely.

B. WIRING.



WARNING: THE FAN AND ANCILLARY CONTROL EQUIPMENT MUST BE ISOLATED FROM THE POWER SUPPLY DURING THE INSTALLATION / OR MAINTENANCE.

IMPORTANT

- The fan should only be used in conjunction with fixed wiring.
- The cross - sectional area of supply cord used should be ranged from 1 -1.5mm².
- Cable entry can only be made from the rear of the fan.
- The extraction fan is suitable for connection to 220-240V 50Hz supply.
- The fan is a class II double insulated product and **MUST NOT** be earthed.

1. Select and follow the appropriate wiring diagram. (Fig. 1, 2 or 3)
2. Check all connections have been made correctly and ensure all terminal connections and cable clamps are securely fastened.
3. Ensure the impeller rotates and is free from obstructions.

C. SETUP



WARNING: THE FAN AND ANCILLARY CONTROL EQUIPMENT MUST BE ISOLATED FROM THE POWER SUPPLY DURING THE INSTALLATION / OR MAINTENANCE.

Accessing the control settings – (Fig. 4 and 5)

1. Loosen the screw in the bottom of the grille and remove the front grille.
2. Carefully pull the inner cap from the centre of the fan away from the chassis.
3. Adjust the settings as outlined below.

Trickle speed selection (6l/s or 9l/s) – (Fig. 7)

In normal running mode the fan can extract at either 6l/s (22m³/h) or 9l/s (32m³/h) flow rate. The fan will boost to 15l/s (54m³/h) when the LS connection is switched.

- Factory set at **6l/s** (22m³/h).
- Remove jumper connector (JP1) if **9l/s** (32m³/h) extract flow rate is required.

Constant flow mode – enable/disable the digital flow sensor (Fig. 8)

In the majority of applications constant flow mode will not be required, however to turn this feature on, complete the following:

- Push switch (SW1) into the on position to turn on constant flow mode.
- Push switch (SW1) into the off position to turn off constant flow mode. (Factory set)

IMPORTANT – On first power up, the fan will run through its initialisation routine. This will involve the fan running on maximum speed to calibrate each of the constant flow speeds/settings. Once complete (after approx 1-2 minutes), the fan will run as normal and will not need to be initialised/calibrated again. The fan will remember its settings if there is a power cut.

D. SERVICING AND MAINTENANCE.



WARNING: THE FAN AND ANCILLARY CONTROL EQUIPMENT MUST BE ISOLATED FROM THE POWER SUPPLY DURING MAINTENANCE.

1. At intervals appropriate to the installation, the fan should be inspected and cleaned to ensure there is no build up of dirt or other deposits.
2. Carefully push the front panel of the grille upwards away from the base part of the grille (fig. 6).
3. Wipe the inlets and front face with a damp cloth until clean.

The fan has sealed for life bearings, which do not require lubrication.

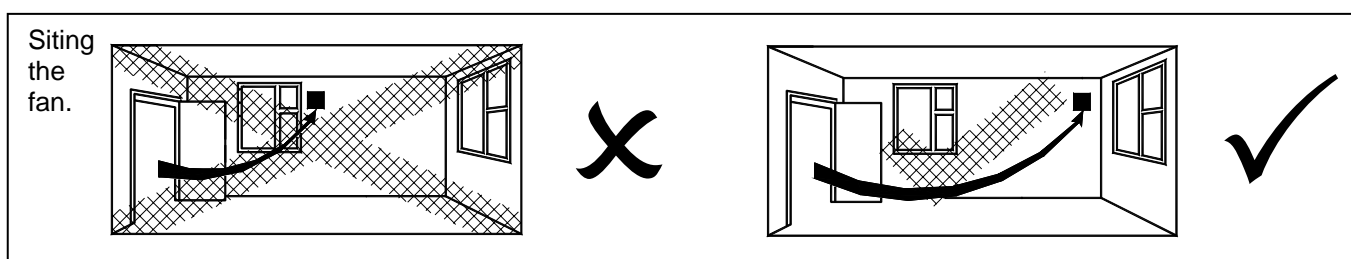

Fig.1 Continuous trickle (6l/s or 9l/s) with no boost facility

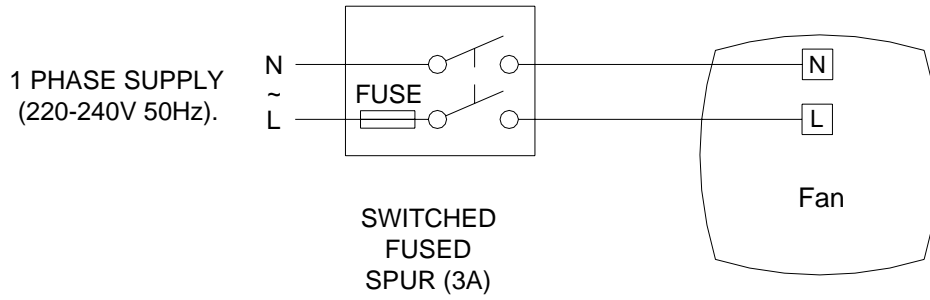

Fig.2 Continuous boost (15l/s) with no trickle facility

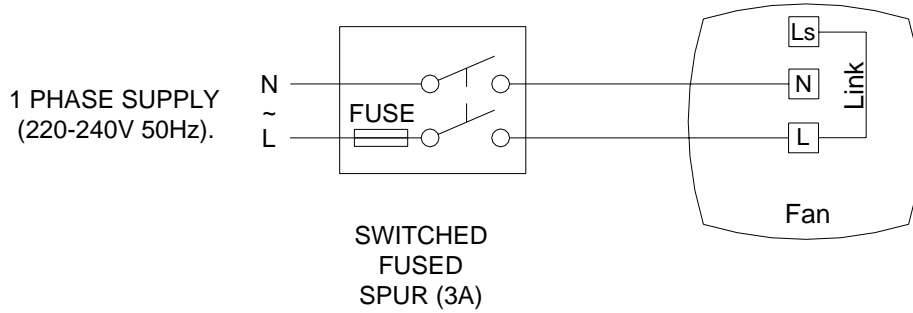

Fig.3 Continuous trickle with boost facility

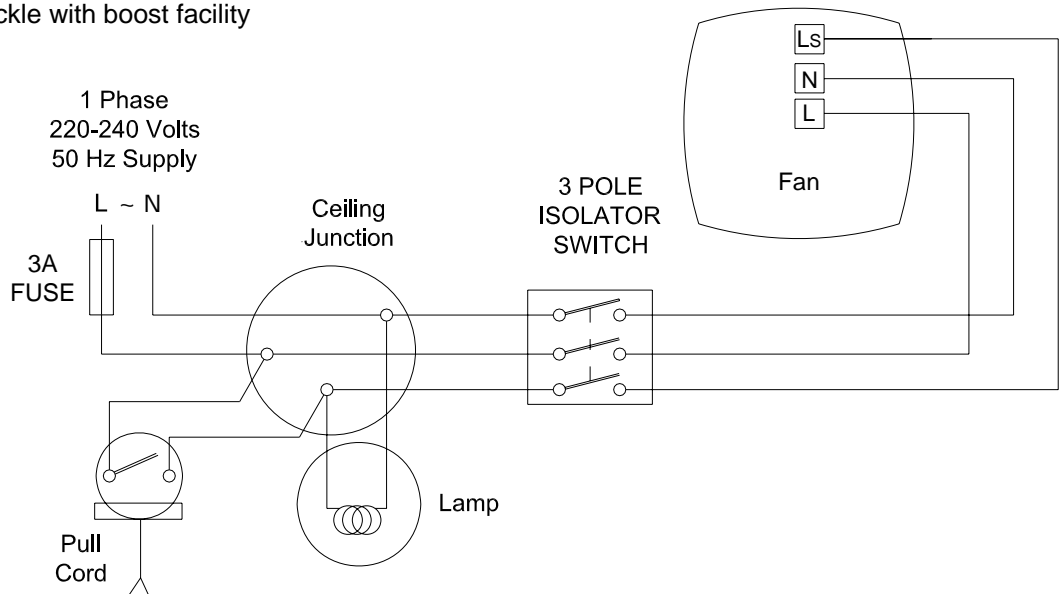
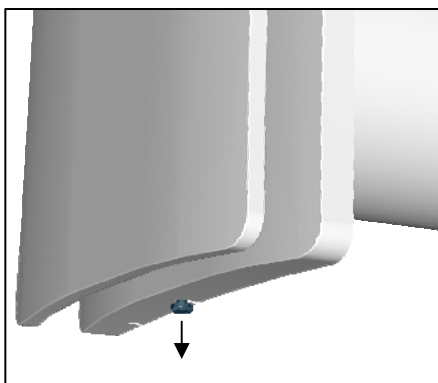
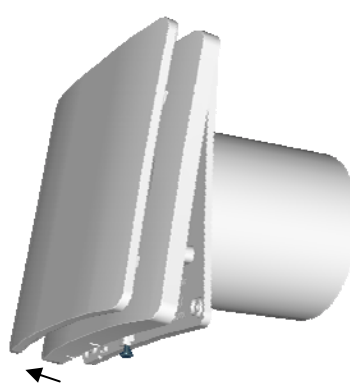

Fig.4. Removing the grille for wiring and setting the controls



1. Loosen screw.



2. Pull grille slightly away from bottom edge.

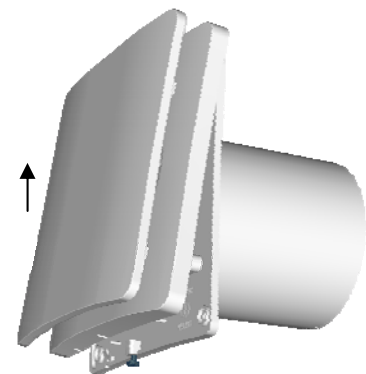

3. Push grille upwards until clear from the fan chassis.

Fig.5. Accessing the control settings

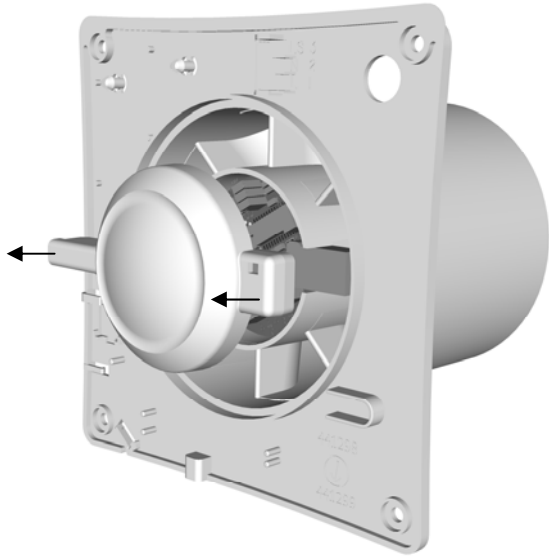

Fig.6. Removing the front grille panel for cleaning.

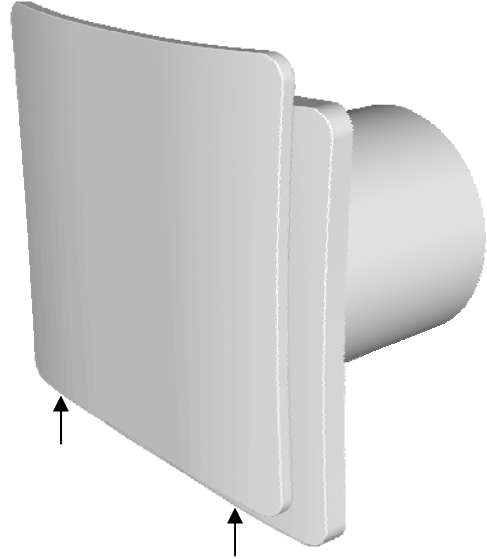
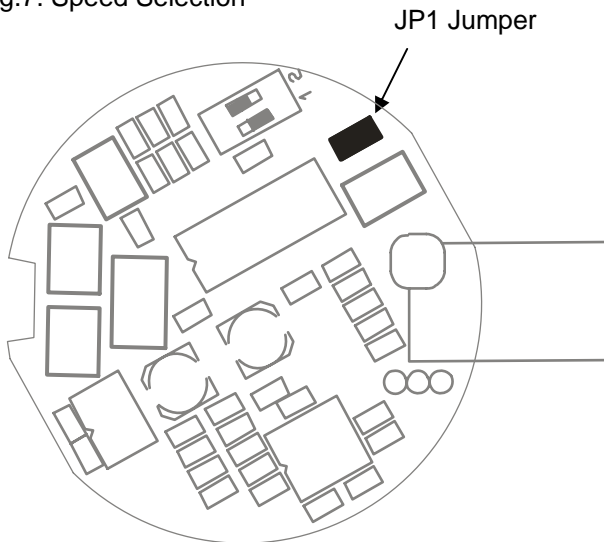

Fig.7. Speed Selection



9l/s = Remove Jumper Connector
6l/s = Replace Jumper Connector (factory set)

(For **15l/s**, permanently link terminal connections L to LS)

Flow rate conversion:

6l/s = 22m³/h
 9l/s = 32m³/h

Fig.8. Constant flow option – using the flow sensor SW1 Dip switch

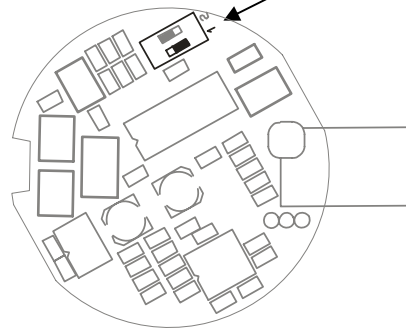

IMPORTANT:
 DO NOT
 CHANGE DIP
 SWITCH 2.
 LEAVE IN OFF
 POSITION

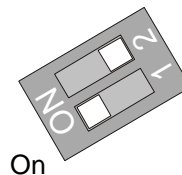

On

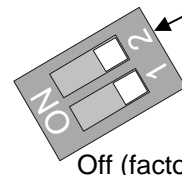

Off (factory set)

Auto sensing mode = Push switch (SW1) into the on position to turn on constant flow mode (enable the digital flow sensor).

Manual mode = Push switch (SW1) into the off position to turn off constant flow mode (disable the digital flow sensor).

Vent-Axia®

Head Office: Fleming Way, Crawley, West Sussex, RH10 9YX. Tel: 01293 526062 Fax: 01293 551188

UK NATIONAL CALL CENTRE, Newton Road, Crawley, West Sussex, RH10 9JA

SALES ENQUIRIES: Tel: 0844 8560590 Fax: 01293 565169

TECHNICAL SUPPORT: Tel: 0844 8560594 Fax: 01293 539209

For details of the warranty and returns procedure please refer to www.vent-axia.com or write to Vent-Axia Ltd, Fleming Way, Crawley, RH10 9YX