

# ***Vent-Axia***®

## **EXTRACTOR HOOD**

### **FITTING AND WIRING INSTRUCTIONS**

**THIS PRODUCT IS MANUFACTURED TO CONFORM WITH THE REQUIREMENTS OF THE FOLLOWING EUROPEAN DIRECTIVES: ELECTROMAGNETIC COMPATIBILITY 89/336/EEC LOW VOLTAGE 73/23/EEC**

**230-240V 50Hz Max 250W**

**PLEASE READ CAREFULLY BEFORE INSTALLATION AND LEAVE WITH END USER**

**PLEASE READ ALL INSTRUCTIONS CAREFULLY BEFORE STARTING INSTALLATION**

THESE INSTRUCTIONS DESCRIBE THE VARIOUS TECHNICAL DETAILS OF YOUR EXTRACTOR HOOD AND ITS USE. THE INSTRUCTIONS COVER MORE THAN ONE MODEL AND MAY REFER TO COMPONENTS THAT ARE NOT PART OF YOUR EXTRACTOR HOOD.

**SAFETY**

If the extractor hood is installed in a room containing a fuel burning appliance the installer must ensure that air replacement is adequate for both the extractor hood fan and the fuel burning appliance.

Do not connect the extractor hood ducting to chimneys, flues or air ducts serving the room.

Do not site where ambient temperatures are likely to exceed 50°C. Do not do any flambé cooking underneath the hood. When frying, NEVER leave the pan unattended in case of fire. This appliance is not suitable for use above an eye level grill.

**Warning:** Failure to comply with the cleaning instructions may result in a risk of fire. The appliance efficiency depends on the condition of the filters.

*All regulations and requirements MUST be strictly followed to prevent hazards to life and property both during and after installation, and during any subsequent servicing and maintenance.*

**GENERAL**

The chimney extractor hood is wall mounted. Extraction or Recirculation modes are available.

The grease filter(s) absorb airborne grease particles so that kitchen furniture and walls remain relatively free of grease and other particles that can cause unpleasant odours.

**Extraction mode.**

For efficiency this mode is recommended since cooking smells, grease and steam are effectively removed from the kitchen through ducting. The extract ducting must be mounted vertically above the centre-line of the extractor hood and pass out through the rear wall or ceiling. The spigot is compatible with either 100mm or 125mm diameter ducting Milano & Roma, Rimini 125mm only.

**N.B.** Remove the carbon odour filters for maximum performance. The efficiency of the hood fan decreases as the length of the ducting and number of bends increase.

If there are any horizontal areas in the extract ducting they must be angled at about 10° upwards towards the outside of the building. Where an excessive amount of moisture is present in the air, a condensation trap may need to be installed in the extract duct. Ducting passing through an unheated roof void should be insulated.

**Recirculation mode.**

This mode is used if ducted extraction is not possible. The air passes through the grease filters first. Then odours are reduced by the carbon filters before the air is recycled into the room. Please fit the carbon odour filters in the hood. The hood spigot is connected to the chimney with the adaptor supplied.

FIG.1

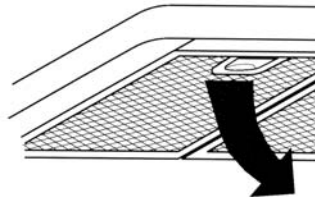
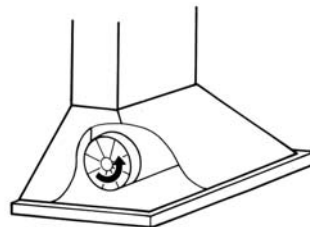

FIG.2



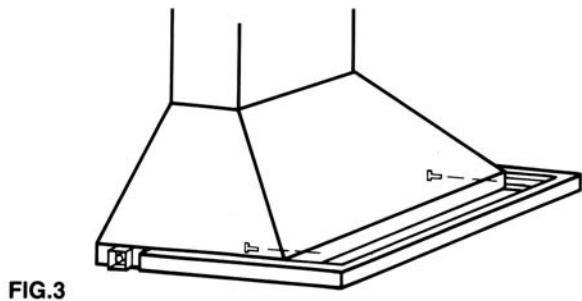

FIG.3

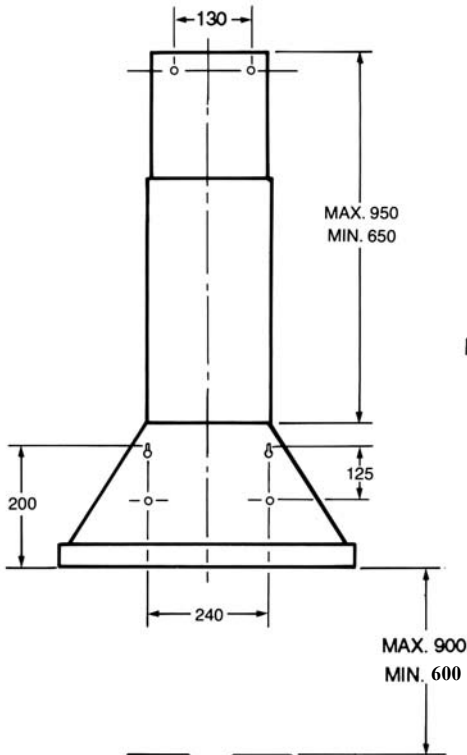

FIG.4

FIG.5

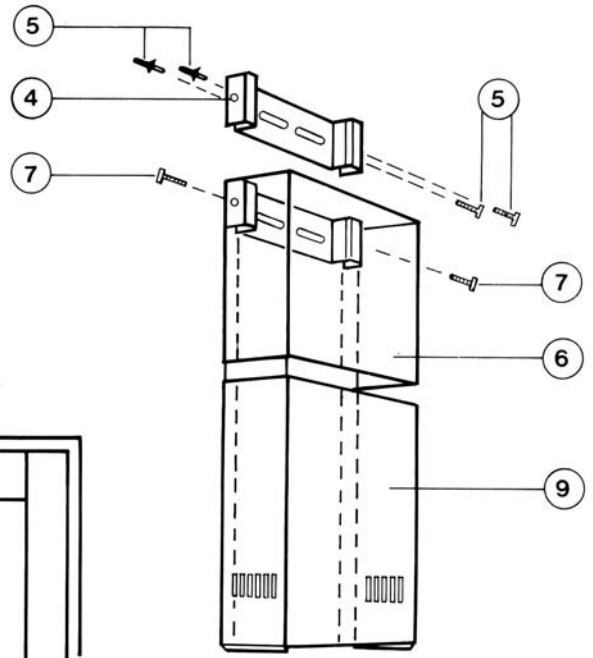
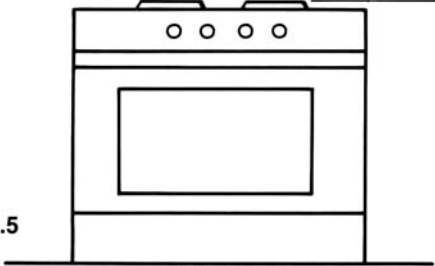

FIG.6

## INSTALLATION

The hood must be mounted over the centre of the cooking area. The distance between the lowest part of the extractor hood and the cooking surface must be not less than 760mm and not more than 900mm. Make sure the wall can support the weight of the hood and chimney ducting

### Wall Fixing of the extractor hood.

**N.B.** Before drilling the wall make sure that no wiring will be damaged. Cut holes for the extract ducting, when required, before mounting the extractor hood and chimney.

1. Fix the spigot (Figure 6/3) onto the hood using the two self tapping screws provided (Figure 6/10).
2. Study Figure 5 and set the distance between the cooking surface and the extractor hood. Mark the positions of the two upper fixing screws (Figure 6/1), drill and fit the wall plugs. Insert the screws and partially tighten.
3. On the extractor hood, pull the grease filter handle(s) downwards (as shown in Figure 1) to release and remove the filter(s). **PUT THE GREASE FILTER(S) CAREFULLY TO ONE SIDE.**
4. Lift the extractor hood and hook the hood onto the wall over the two upper screws (Figure 6/1) through the fixing holes (Figure 6/2). Make sure the screws are tight and secure in the wall.
5. Drill, plug and insert the two lower fixing screws (Figure 6/13) through the fixing holes (Figure 6/12). Make sure the screws are tight and secure in the wall.
6. For extraction mode securely fasten the 100mm or 125mm diameter extract ducting (Figure 6/11) to the hood spigot using a 100mm adaptor, if required. Ducting installation should conform to the requirements of the "General" section.
7. For recirculation mode securely fasten the T-shaped adaptor provided (Figure 6/11) to the hood spigot. See also the "General" section notes.

### **WIRING**

*All electrical connections should be made by a properly qualified electrician. The extractor hood siting, wiring and installation MUST comply with the current I.E.E. Regulations (UK) or the appropriate standards in your country.*

This product is manufactured to comply with the Radio Interference requirements of E.E.C. Directives. This appliance is complete with mains lead and appropriate lamps.

**WARNING: This appliance MUST NOT be earthed. It is double insulated. This appliance MUST be connected to a 230-240V 50Hz AC single phase mains supply. ENSURE THAT THE MAINS SUPPLY IS ISOLATED BEFORE MAKING ELECTRICAL CONNECTIONS.**

The installation MUST be provided with a double pole isolator switch with a contact separation of at least 3mm. Alternatively a suitable 3 pin plug may be used.

For fixed wiring circuits the protective fuse for the appliance must not exceed 5A (UK). Where the appliance is intended to be connected via a plug and flexible mains lead, an approved plug must be used.

**UK:** If an approved 13A (BS 1363) plug is used it must be fitted with a 3A fuse (BS 1362).

### **IMPORTANT**

The wires in the mains lead are coloured in accordance with the following code:-

#### **BLUE - NEUTRAL, BROWN - LIVE**

These wire colours may not match the coloured markings identifying the terminals of your plug, in which case follow the procedure below:-

The BLUE coloured wire must be connected to the terminal marked with the letter N or coloured Black.

The BROWN coloured wire must be connected to the terminal marked with the letter L or coloured Red.

**NEITHER WIRE** is to be connected to the Earth terminal of a 3 pin plug marked with the letter E, or by the Earth symbol , or coloured Green, or coloured Green and Yellow.

**N.B.** Double check the wiring and make sure all connections are secure.

### **Installing the chimney**

These instructions apply to both extract and recirculation modes. N.B. Before drilling the wall make sure that no wiring will be damaged.

1. Determine the maximum height of the chimney (Figure 5), then mark the positions of the two bracket fixing screws (Figure 6/5). Drill and fit the wall plugs. Insert the two captive nuts into the two opposite square holes on the inside of the bracket. Attach the bracket (Figure 6/4) to the wall using the two screws. Make sure the screws are tight and secure in the wall.
2. Mount the shorter section of chimney (Figure 6/6) onto the bracket using the two screws (Figure 6/7). Carefully remove the protective film from the metal.

3. Insert the two captive nuts into the two centre square holes on the inside of the lower part of the longer section of chimney. Fit the longer section of chimney (Figure 6/9) over the shorter section by pulling the sides slightly apart.

4. Use the two screws (Figure 6/8) to attach the hood to the long chimney section. Carefully remove the protective film from the metal. Replace the each grease filter by first pulling handle downwards, placing in position and releasing handle to lock. Switch the mains supply on.

### **USING THE EXTRACTOR HOOD**

The extractor hood should be switched on either before or at the same time as cooking or frying commences. The grease and carbon filters are more effective if the fan is left running for about 20 to 30 minutes after cooking is complete.

**To switch on/off the extractor hood fan:** Use the switch shown in Figure 4/1 to select the speed required.

**To switch on/off the extractor hood lighting:** Use the switch shown in Figure 4/2. The lamps work independently of the fan.

### **CLEANING AND MAINTENANCE**

**WARNING: ALWAYS ENSURE THAT THE MAINS SUPPLY IS ISOLATED FIRST.**

#### **General Cleaning.**

As often as needed, wipe the outside of the chimney extractor hood with a sponge soaked in mild liquid detergent. Do not use harsh cleaning chemicals or products with abrasives.

**N.B.** The appliance efficiency depends on the condition of the filter(s).

#### **Metallic Mesh Grease Filter(s).**

The filter(s) absorb airborne grease particles and should be washed every ten to fifteen days of hood operation, or at more or less frequent intervals depending on how often the hood is used.

ISOLATE the mains supply. Pull filter handle(s) downwards (as shown in Figure 1) to release and remove the filter(s). Wash the filter(s) by dipping in degreaser solution, or putting them in a dishwasher, or by hand using mild liquid detergent. Rinse thoroughly and carefully press on a cloth to dry. **DO NOT CRUSH THE FILTER MATERIAL** - it is made of several layers of thin metal and must be handled with care.

Refit filter(s) by first pulling handle downwards, placing in position and releasing handle to lock.

#### **Carbon Odour filters.**

Required for recirculation mode. The air passes through the active carbon filters and is cleaned before recirculation into the room. **THE FILTER(S) CANNOT BE WASHED.** The filter(s) must be replaced about twice a year, depending on how often the hood is used.

ISOLATE the mains supply. Remove the grease filter(s) as described above to gain access. Remove the old carbon filters by turning anti-clockwise as shown in Figure 2. Insert the new carbon filters, turning clockwise to engage, and replace the grease filter(s).

#### **Frame Cleaning and Replacement.**

Remove the two screws inside the front of the hood as shown in figure 3. Carefully pull forwards both corners of the frame equally so as not to distort or break the frame. Carefully clean the frame with mild liquid detergent. Reverse these instructions to replace the frame.

#### **Lamp Replacement.**

ISOLATE the mains supply. Carefully remove the extractor hood lamp lens for access. If the lamp(s) fail to light when using the switch shown in Figure 4/2, first check that they are screwed in tightly. Replace the extractor hood lamp lens.

The lamps must only be of the tubular type as originally supplied. (Replacement Part No. 451133). Never use lamps with a higher rating than that indicated on the extractor hood lamp lens.

# VENT-AXIA CONTACT NUMBERS

## UK NATIONAL SALES CENTRE

### Domestic & Commercial

Tele: 01293 530202

Fax: 01293 565169

### Industrial

Tele: 01293 441570

Fax: 01293 534898

## REPUBLIC OF IRELAND

Vent-Axia Ventilation Ltd.

921 Western Road Industrial Estate

Naas Road, Dublin 12.

Tele: (01) 450 4133

Fax: (01) 450 4570

## UK NATIONAL TECHNICAL SUPPORT

### Domestic & Commercial

Tele: 01293 526062

Fax: 01293 551188

### Industrial

Tele: 01293 455196

Fax: 01293 455197

Internet site at: [www.vent-axia.com](http://www.vent-axia.com)

Email: [info@vent-axia.com](mailto:info@vent-axia.com)

### The Vent-Axia Guarantee

Applicable only to products installed and used in the United Kingdom. For details of the Guarantee outside of the United Kingdom contact your local supplier.

Vent-Axia guarantees this product for one year from the date of purchase against faulty material or workmanship. In the event of any part being found to be defective, the product will be repaired, or at the Company's discretion the product will be replaced without charge, provided that the product:

- 1). Has been installed and used in accordance with the instruction given with each unit.
- 2). The electricity supply complies with the rating label.
- 3). Has not been misused, neglected or damaged.
- 4). Has not been modified or repaired by any person not authorized to do so by Vent-Axia.

### IF CLAIMING UNDER THE TERMS OF THE GUARANTEE

Please return the complete product, carriage paid to your original supplier by post or in person. Please ensure that it is adequately packed and accompanied by a letter clearly marked 'Guarantee Claim' stating the nature of the fault and providing proof of the date and source of purchase

As part of the policy of continuous product improvement  
Vent-Axia reserve the right to alter specifications without notice

## **Vent-Axia**

**Head Office:** Fleming Way, Crawley, West Sussex RH10 9YX

Tel: 01293 526062 Fax: 01293 551188

Internet site at: [www.vent-axia.com](http://www.vent-axia.com)