

Vent-Axia®

AIRTRAK POWERFLOW ACP FAN RANGE IN-LINE CENTRIFUGAL DUCT FANS

Installation and Wiring Instructions

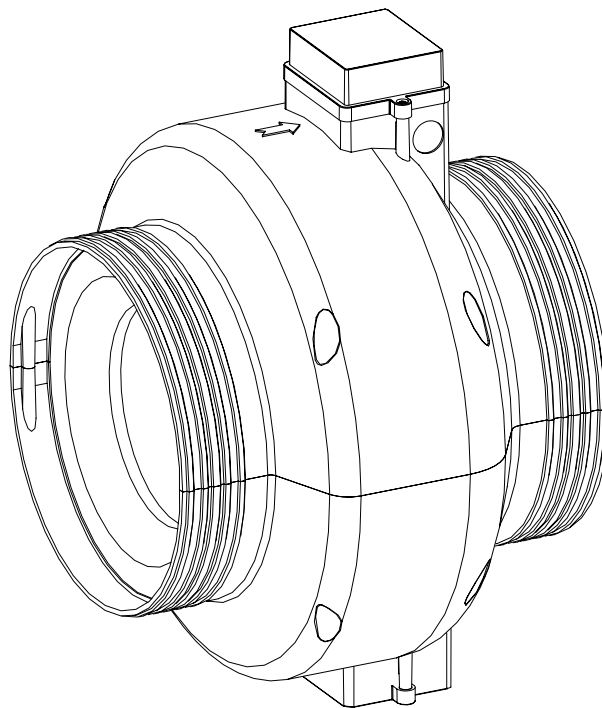

Stock Ref. N°

ACP 100-12B	ACP 160-12B	ACP 315-12B
ACP 125-12B	ACP 200-12B	ACP 315-12HP
ACP 150-12B	ACP 250-12B	

220-240V/1/50Hz



*READ INSTRUCTIONS IN CONJUNCTION WITH ILLUSTRATIONS
READ AND SAVE THESE INSTRUCTIONS*

Installation and Wiring Instructions for AIRTRAK POWERFLOW (ACP) fan range.



IMPORTANT:

READ THESE INSTRUCTIONS BEFORE COMMENCING THE INSTALLATION

DO NOT install this product in areas where the following may be present or occur:

- Excessive oil or a grease laden atmosphere.
- Corrosive or flammable gases, liquids or vapours.
- Ambient temperatures higher than 40°C or less than -5°C.
- Relative humidity above 95%
- Possible obstructions which would hinder the access or removal of the fan.
- Sudden ductwork bends or transformations close to the fan.

SAFETY AND GUIDANCE NOTES

- A. All wiring must be in accordance with the current I.E.E. Regulations, or the appropriate standards of your country.
- B. The fan should be provided with a local double pole isolator switch having a contact separation of at least 3mm.
- C. Ensure that the mains supply (Voltage, Frequency and Phase) complies with the rating label.
- D. The fan should only be used in conjunction with the appropriate Vent-Axia products.
- E. It is recommended that the connection to the terminal box is made in flexible cable or conduit for easy maintenance.
- F. The fan should not be sited within 600mm horizontally of/or 2250mm vertically of a bath/shower tray, in accordance with the current I.E.E. Regulations for bathrooms.
- G. When the fan is used to remove air from a room containing a fuel-burning appliance, ensure that the air replacement is adequate for both the fan and the fuel-burning appliance.
- H. If the fan is used to supply air into a room, the installer must ensure that the fan intake is located a minimum of 600mm from any flue outlet.
- I. This fan is designed as an inline duct fan to be positioned between lengths of ducting. Short duct runs terminating within 1.5m must incorporate suitable guards unless the fan is mounted higher than 2.3m.
- J. This fan should not to be used where it is liable to be subject to direct water spray from hoses etc.
- K. Where ducted fans are used to handle moisture-laden air, a condensation trap should be fitted. Horizontal ducts should be arranged to slope slightly downwards away from the fan.
- L. Certain applications may require the installation of sound attenuation material to achieve the sound levels required. An auto transformer speed controller is also recommended.

INSTALLATION

FAN MOUNTING

1. The fan is suitable for mounting at any angle using the mounting bracket supplied.
2. Securely mount the fan using the appropriate screws, bolts, anti-vibration mounts etc.
3. Flexible connections should be used at the fan inlet and outlet.
4. Ensure that there is adequate clearance for accessing the fan.

WIRING



WARNING: THE FAN AND ANCILLARY CONTROL EQUIPMENT MUST BE ISOLATED FROM THE POWER SUPPLY DURING THE INSTALLATION / OR MAINTENANCE. THE EQUIPMENT MUST BE EARTHED

1. Select and follow the appropriate wiring diagram (*Figs. 1-4*).
2. Check that all connections have been made correctly. Ensure that all terminal screws and cable clamps are securely fastened.
3. The cable entry must be made using a suitable grommet or cable gland.
4. Switch the mains supply on and check the system is operating correctly.

ROUTINE INSPECTION AND MAINTENANCE

ISOLATE THE UNIT FROM THE POWER SUPPLY AND ENSURE THAT IT CANNOT BE ACCIDENTALLY SWITCHED BACK ON

1. At intervals appropriate to the installation, the fan should be inspected and cleaned to ensure there is no build up of dirt or other deposits on the impeller or the motor (Caution – do not dislodge any balance weights which may be fitted to the impeller). If the fan is handling dust laden air, it is recommended that a filter is installed.
2. All Vent-Axia AIRTRAK fan motors are fitted with sealed for life bearings and do not require lubrication.

OVERHEATING PROTECTION

The fan motor is fitted with Standard Thermal Overload Protection. This will automatically switch the fan Off in the event of a fault condition. If this occurs, isolate the fan, check for any obstruction, leave the fan for a short time for the motor to cool before reconnecting the power supply. If the fault reoccurs, isolate the power supply and call a service engineer.

Fig. 1
Fan Controlled by a Remote Switch

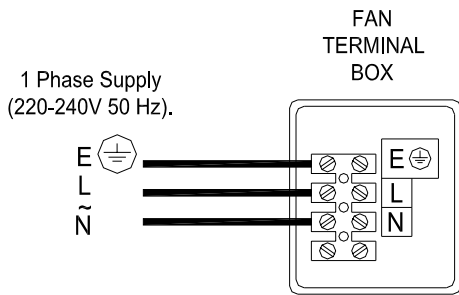

Fig. 2
Fan Controlled by a 2.5 Amp Electronic Speed Controller (Stk Ref. W103-03-102M).

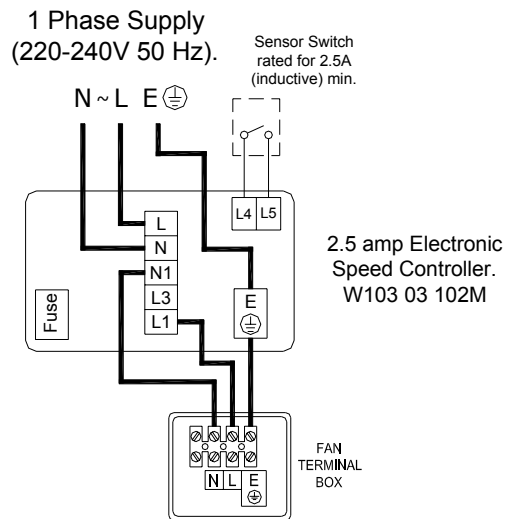

Fig. 3
Fan Controlled by a 3.0 Amp Electronic Speed Controller

(Stk Ref. 103-03-103A).

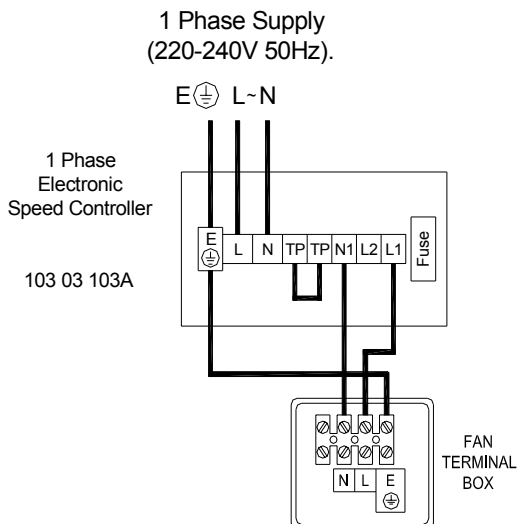
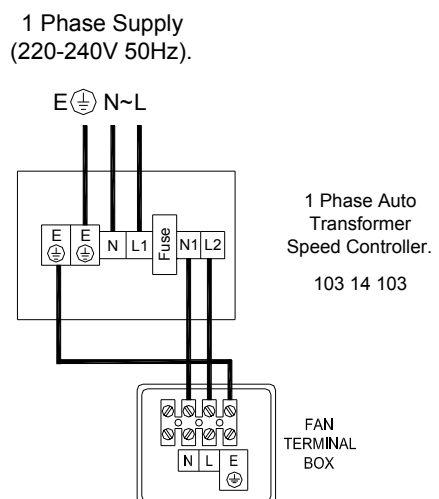

Fig. 4
Fan Controlled by a 3.0 Amp Auto Transformer Speed Controller

(Stk Ref. 103-14-103).



VENT-AXIA SALES CENTRES

ENGLAND & WALES NATIONAL CALL CENTRE

Newton Road, Crawley
West Sussex
RH10 9JA

Telephone: 01293 530202
Fax: 01293 565169

NORTHERN IRELAND

Telephone: 02890 402220
Fax: 01293 565169

SCOTLAND

Telephone: 0141 429 1166
Fax: 01293 565169

REPUBLIC OF IRELAND

Vent-Axia Ventilation Ltd.
921 Western Industrial Estate
Naas Road, Dublin 12.

Telephone: (01) 450 4133
Fax: (01) 450 4570

Did you find these instructions easy to use?

We value your comments, contact us via:

email: info@vent-axia.com

The Vent-Axia Guarantee

Applicable only to products installed and used in the United Kingdom. For details of the guarantee outside the United Kingdom contact your local supplier.

Vent-Axia guarantees its products for two years from the date of purchase against faulty material or workmanship. In the event of any part being found to be defective, the product will be repaired, or at the Company's opinion replaced, without charge, provided that the product:

- 1) has been installed and used in accordance with the instructions given with each unit.
- 2) has not been connected to an unsuitable electricity supply (The correct electricity supply voltage is shown on the product rating label attached to the unit).
- 3) has not been subjected to misuse, neglect or damage.
- 4) has not been modified or repaired by any person not authorised by the Company.

IF CLAIMING UNDER THE TERMS OF THE GUARANTEE

please return the complete product, carriage paid to your original supplier or nearest Vent-Axia Centre, by post or in person. Please ensure that it is adequately packed and accompanied by a letter clearly marked 'Guarantee Claim' stating the nature of the fault and providing proof of date and source of purchase.

As part of the policy of continuous product improvement Vent-Axia reserve the right to alter specifications without notice.

Vent-Axia®

Head Office: Fleming Way, Crawley, West Sussex RH10 9YX
Tel: 01293 526062 Fax: 01293 551188
Internet site at: www.vent-axia.com