

Lo-Carbon PoziDry

Positive Pressure Ventilation Unit

Installation and Wiring Instructions

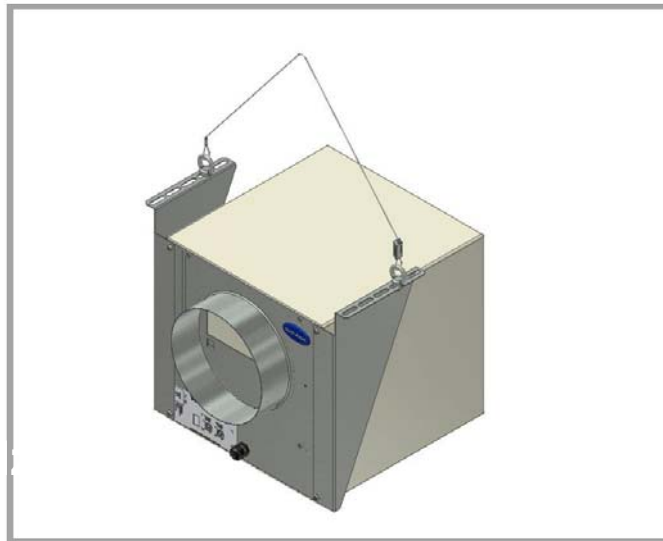

Stock Ref. N°

444766 – With integral heater
444075 – Without heater

Vent-Axia[®]

PLEASE READ INSTRUCTIONS IN CONJUNCTION WITH THE ILLUSTRATIONS.
PLEASE SAVE THESE INSTRUCTIONS

IP22

CE



Installation and Wiring Instructions for the Lo-Carbon PoziDry Positive Ventilation Unit.

IMPORTANT:

READ THESE INSTRUCTIONS BEFORE COMMENCING THE INSTALLATION

SAFETY AND GUIDANCE NOTES

1. DO NOT install this product in areas where the following may be present or occur:
 - 1.1. Excessive oil or a grease laden atmosphere.
 - 1.2. Corrosive or flammable gases, liquids or vapours.
 - 1.3. Ambient temperatures higher than 40°C or less than -5°C.
 - 1.4. Possible obstructions which would hinder access or removal of the Fan.
 - 1.5. Relative humidity above 90%
 - 1.6. Sudden ductwork bends or transformations close to the Unit.
2. All wiring to be in accordance with the current I.E.E. Regulations, or the appropriate standards of your country and **MUST** be installed by a suitably qualified person.
3. The fan should be provided with a 3A fused, isolator switch capable of disconnecting all poles, having a contact separation of at least 3mm.
4. Ensure that the mains supply (voltage, frequency, and phase) complies with the fan's rating label.
5. The fan should not be used where it is liable to be subjected to direct water spray.
6. This appliance is not intended for use by persons (including children) with reduced physical, sensory or mental capabilities, or lack of experience and knowledge, unless they have been given supervision or instruction concerning use of the appliance by a person responsible for their safety.
7. Children should be supervised to ensure that they do not play with the appliance.

A. INTRODUCTORY NOTES

The Vent Axia Lo-Carbon PoziDry is a positive input ventilation unit, designed to be installed in the loft of a dwelling to continually supply filtered fresh air into the building.

The system consists of a fan unit and a discharge grille with a short length of flexible ducting connecting the two.

The Lo-Carbon PoziDry has two fully adjustable speed settings; 'Trickle' and 'Normal'. These speeds are set on installation, but to aid commissioning there are pre-marked settings to suit the characteristics of the house

The Lo-Carbon PoziDry uses a sensor to monitor the temperature in the loft, automatically adjusting the air volume when necessary.

'Trickle' speed is automatically selected when the ambient loft temperature is up to 18°C.

'Normal' is automatically selected when the ambient loft temperature is between 18 and 27°C.

If the ambient loft temperature exceeds 27°C, the Lo-Carbon PoziDry will automatically switch to standby (no airflow).

The standby power consumption is 2W.

In the case of the integral 500W heater version (444766), the heater element is automatically activated when necessary and tempers the supply air to 10°C.

By wiring in a switch on installation it is possible to switch off the heater if necessary. See WIRING on page 5/6.

The Vent Axia Lo-Carbon PoziDry has the capability to run on Purge setting (maximum speed); this is particularly useful for installations where condensation is a severe problem.

To enable 'Purge' speed, connect a switched live connection to the LS core on the integral mains flying lead. See WIRING on page 5/6.

The unit also incorporates a non-resettable elapsed hours counter.

B. INSTALLATION

CAUTION: The Lo-Carbon PoziDry discharges the incoming air along the ceiling and therefore may disrupt the operation of smoke detectors sited nearby. Therefore the Lo-Carbon PoziDry should not be situated within 1m (3ft) of any smoke detector.

After installation check the operation of smoke detectors by running the Lo-Carbon PoziDry at maximum output.

TYPICAL INSTALLATION

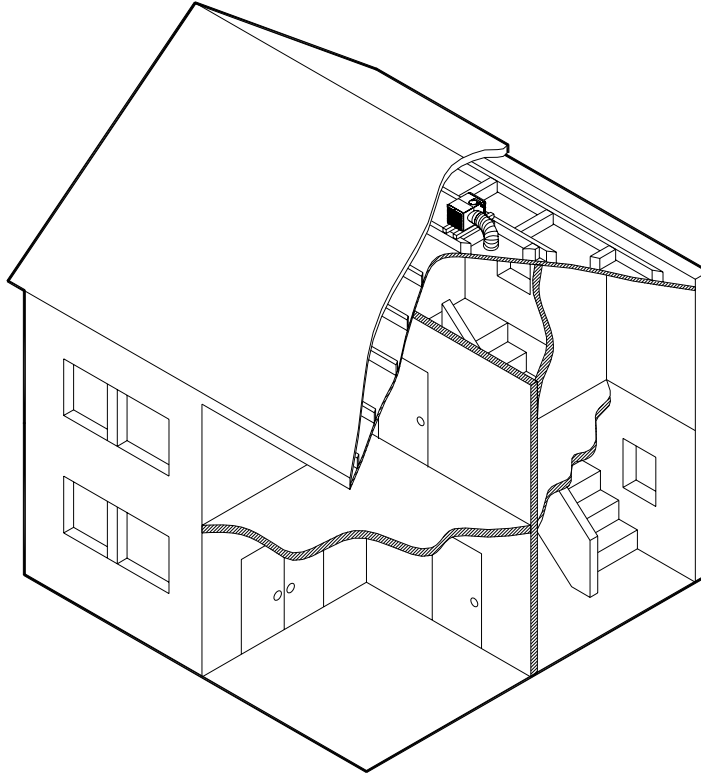

Lo-Carbon PoziDry UNIT:

Prior to installation ensure that the loft is adequately ventilated. The following tips can be used as a basis for this. However this is not an exhaustive list.

Ensure that any ridge vents, tile vents and continuous air gaps are not blocked. These may not be present in older properties, however there should be enough 'leakage' to accommodate the requirements of the Lo-Carbon PoziDry unit.

One method of checking this is by entering the loft, closing the loft hatch, switching off the lights and looking for any daylight penetration. If daylight is visible it is reasonable to assume that there is adequate ventilation within the loft.

There may well be occasions where a loft is so well sealed that additional ventilation may need to be provided by the owner/occupier. This will not only assist the operation of the Lo-Carbon PoziDry, but may also help to prevent future expensive structural damage caused by inadequate air movement. It should be noted that there can never be too much ventilation in a loft.

Ensure that all water tanks are covered and sealed.

Check that all water pipes are lagged.

Ensure that any extract fans are discharging to the outside and not into the loft.

Check that the loft hatch is tightly sealed.

Ensure that all holes in the ceilings are sealed, i.e. ceiling light fittings etc.

A visual inspection of any flues or chimneys for leakage in the loft should be carried out by the installer.

If any leakage points are found, or if there is any doubt at all, the installer should advise the house owner/provider as soon as possible and seek instruction from them before proceeding with the installation.

Flexible ducting is supplied as standard. Ensure that this is pulled out and does not allow any moisture to collect, it should be a smooth single curve to the grille. If the application requires a fixed 90 degree bend and straight ducting may be used. See Spares and Accessories on page 7.

Hanging method:

The Lo-Carbon PoziDry can be hung from a roof beam (Fig. 4). Fix the eye bolts to the appropriate slots in the feet so that the unit is balanced. Suspend from an appropriate hook, or equivalent, attached to a convenient roof beam. An adjuster is provided to adjust the length of the wire, if required.

Ensure that the route for the flexible ducting has gentle bends and that the duct can not be crushed.

The method of fixing the wire to the roof beam is the responsibility of the installer. Ensure that the hook device attached to the beam is strong enough and that the beam is in sufficient condition to withstand the load. The unit weight is approximately 15 kg.

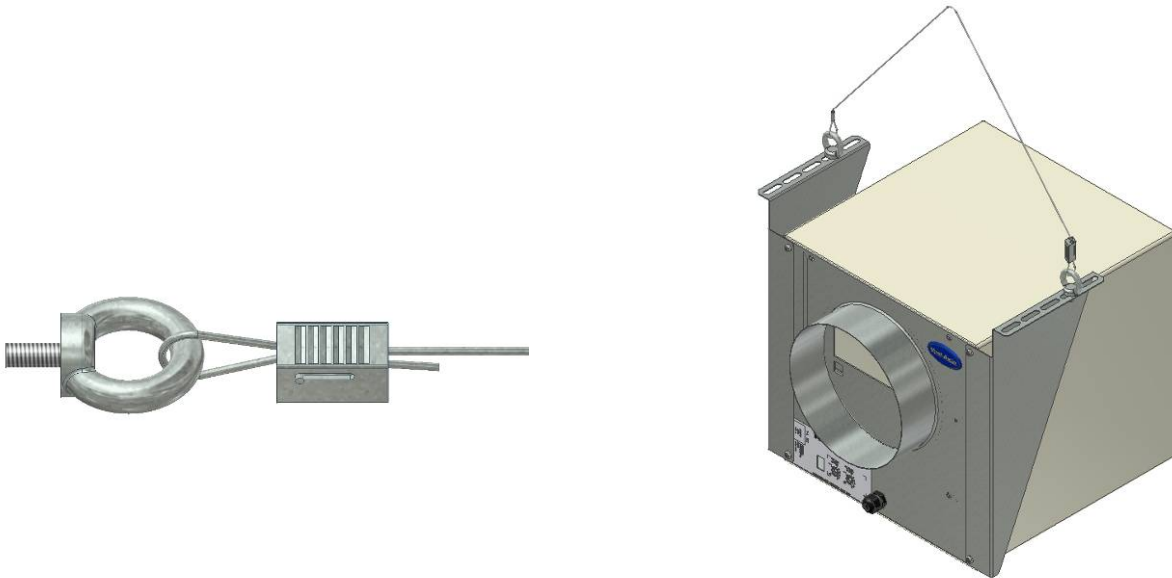

Floor mounting:

Remove the feet brackets from the unit and replace them so that the unit (and hence the display) will be the right way up.

Cut two lengths of 25mm x 50mm (1in x 2in) sawn timber batten to suit the span of the ceiling joists. An accessory kit containing four anti-vibration feet is available, see page 8. Attach these, if needed, to the Lo-Carbon PoziDry using the supplied M8 bolts and washers.

Position the Lo-Carbon PoziDry onto the two sawn timber battens and ensure it is within easy reach of the discharge grille. Ensure that the route for the flexible ducting has gentle bends and that the duct can not be crushed. Screw the 4 anti vibration feet to the two sawn timber battens.

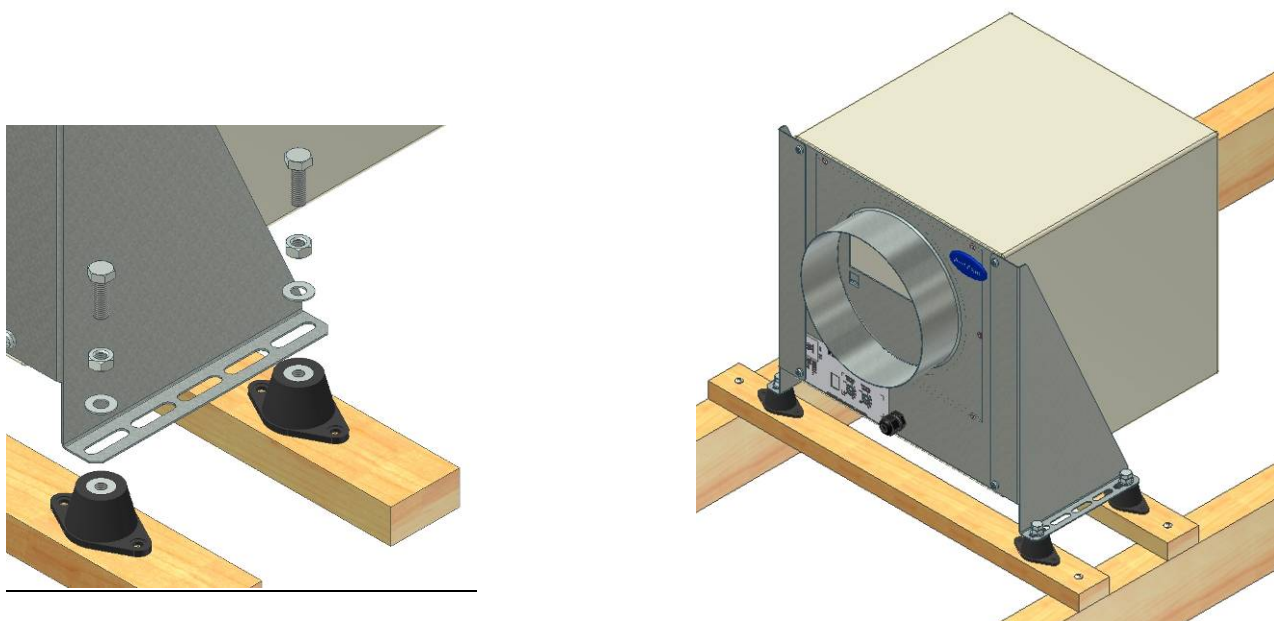

DISCHARGE GRILLE:

The discharge grille must be carefully sited to ensure the maximum effectiveness of the system. This grille should be fitted in the ceiling of a common area, ideally above the landing so that the incoming air can reach all the rooms.

Do not cut the flexible ducting. The ducting **must** remain a minimum of 1m in length.

Remove the loft insulation from the location of the discharge grille and cut a 200mm dia hole in the ceiling.

Pull the plastic diffuser plate off the magnets that retain it on the spigot base. Position the spigot base in the ceiling hole and mark the fixing hole positions. Drill and insert the appropriate fixings (e.g. plasterboard rawlplugs; not supplied) into these holes to suit No. 8 screws.

Pass the spigot base through the ceiling hole and fix it to the ceiling with 1-1/2 inch long No. 8 screws (not supplied). Attach the plastic diffuser plate to the spigot base using the magnets. Fit the free end of the flexible ducting to the discharge grille spigot using the worm drive clip supplied.

The Lo-Carbon PoziDry should not be situated within 1m of a smoke detector, however if this is not possible the Lo-Carbon PoziDry has provisions to blank off the airflow for up to three sides of the diffuser. To do this, cut the closed cell foam material to size and utilising the self adhesive backing, stick the foam strip to the metal base. Once securely located put the plastic diffuser plate in place using the magnetic attachment.

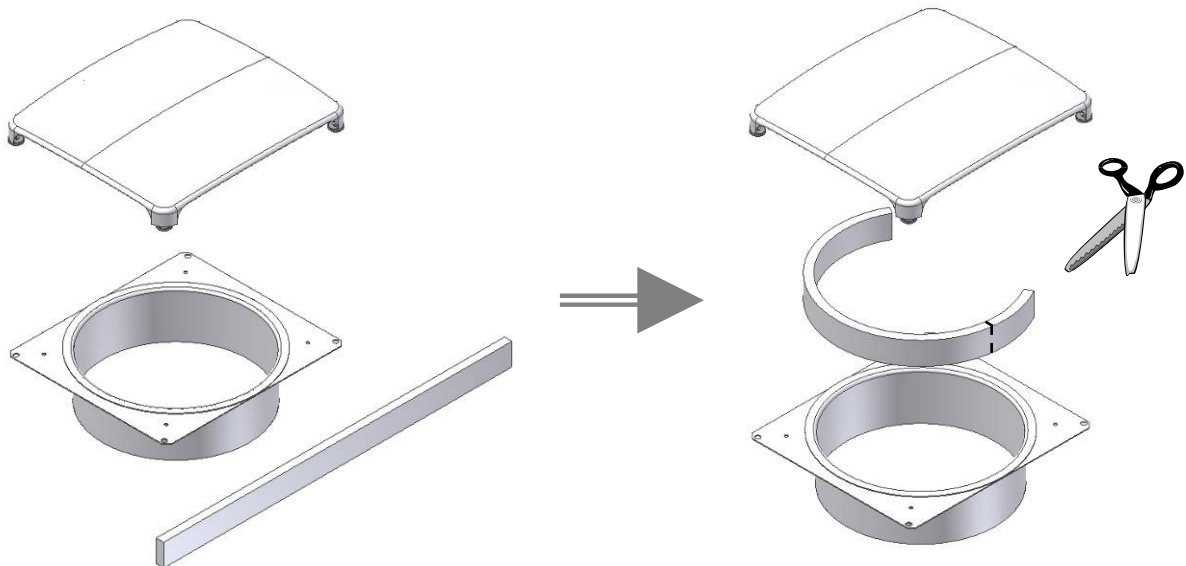

C. WIRING



WARNING: THE POSITIVE VENTILATION UNIT AND ANCILLARY CONTROL EQUIPMENT MUST BE ISOLATED FROM THE POWER SUPPLY DURING THE INSTALLATION / OR MAINTENANCE.

THE Lo-Carbon PoziDry (POSITIVE VENTILATION UNIT) MUST BE EARTHED.

Mains supply voltages (220-240V ac) are present in this equipment which may cause death or serious injury by electric shock. Only a qualified electrician or installer should connect the power supply to this unit. The Lo-Carbon PoziDry is designed for operation from a single-phase alternating current source (220-240V AC).

A 1.2 m integral mains flying lead is connected to the unit for connection to a 3A switched fused spur. It should be capable of disconnecting all poles, having a contact separation of at least 3mm.

TO CONNECT A POWER SUPPLY:

- Ensure the local AC power supply is isolated.
- The product has a pre-wired flying lead. Connect the brown core to Live, blue core to Neutral, green/yellow to Earth, and black to LS (for 100% PURGE if required).

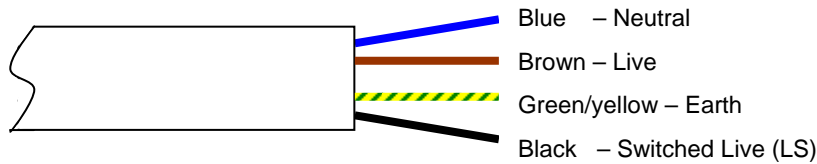

- Use cable clamps and clips to secure the cable, as appropriate.

TO CONNECT A REMOTE SWITCH FOR THE HEATER:

- Ensure the local AC power supply is isolated.
- Remove the cover over the electronics enclosure. Identify the cables to the heater and extend one of them to the local switch (typically installed in a cupboard, on the landing or on a kitchen wall) and back to the unit.

D. START UP SEQUENCE

The Lo-Carbon PoziDry will perform a start up test procedure on **every** power up.

During this sequence, the following will occur:

- 1) Motor goes to full speed.
- 2) LED segments light up one at a time until all 7 are lit.
- 3) Potentiometers and Thermistor are measured and the motor pulses counted. If any of these sources shows an error, then it is displayed. A list of error codes is shown below.
- 4) Motor goes to lowest (Trickle) speed; if the motor stalls then an 'error' is displayed. Otherwise the display shows 'n' indicating Trickle speed.
- 5) After 10 seconds the heater is turned on, the display now shows 'h.' for heat.
- 6) After 20 seconds (to allow the element to warm up) the heater is turned off, the motor goes to maximum Normal speed to cool the heater and the display shows 'b' indicating Normal speed.
- 7) After 10 seconds the display shows the elapsed hours. Six digits are displayed sequentially immediately after the 'b'. For example, 000048 would indicate 2 complete days has elapsed.**
- 8) The unit exits the test mode and runs at the appropriate rate whilst displaying a rotating segment display. The rate will depend upon ambient temperature.

The POZIDRY PLUS has built in fault detection software to ensure continual safe functioning.

If any of these faults are displayed on the LCD display please contact Technical Support on 0844 8560594.

F1 = open circuit thermistor i.e. not connected.

F2 = short circuit thermistor i.e. wires, PCB or thermistor shorted.

The above codes are mutually exclusive so cannot occur at the same time.

F3 = Motor Tachometer signal failure or fan not rotating.

F4 = Motor AND open circuit thermistor failures.

F5 = Motor AND short circuit thermistor failures.

CAUTION:

As the heater element is activated during this sequence, the ducting **must** be attached.

Please take extreme caution after the self test as the unit may become hot.

Note that if the unit is hanging the display is upside down.

E. COMMISSIONING

The Lo-Carbon PoziDry has two speed settings, 'Trickle' and 'Normal'.

'Trickle' speed is automatically selected when the ambient loft temperature is **below 18°C**.

'Normal' is automatically selected when the ambient loft temperature is **between 18°C and 27°C**.

If the ambient loft temperature exceeds 27°C, the Lo-Carbon PoziDry automatically switches to standby (no airflow).

The speed settings on the Lo-Carbon PoziDry are fully adjustable via the potentiometers located on the front of the unit.

However, for ease of adjusting during commissioning there are 6 pre-marked settings to assist in speed selection.

As marked on the unit, the **left hand** potentiometer controls the 'Trickle' speed setting.

The **right hand** potentiometer controls the 'Normal' speed setting.



WARNING: THE BLUE POTENTIOMETER DRIVER SUPPLIED WITH THE UNIT MUST BE USED TO ADJUST THE POTENTIOMETERS.

Turning the potentiometer **clockwise** will increase the speed.

Once the Lo-Carbon PoziDry speeds are set, apply the supplied white label (442657A) over marked area containing 'Trickle' and 'Normal' holes to ensure the potentiometers are inaccessible and so that the unit returns to an IPX2 rated status.

The fan speeds must be selected to suit the condensation level of the house.

The condensation level of a house is affected by a combination of factors and not just house size, but research by the Building Research Establishment and other bodies has shown that a ventilation rate equal to half the volume of the house per hour will provide adequate background ventilation, therefore for ease of installation the Lo-Carbon PoziDry can be commissioned based on house size.

Based on this air change rate; the following speeds are recommended:

'Trickle' Setting 1 = 10 l/s (36m ³ /h)	power consumption 2.5W	- floor area up to 72m ² .
'Trickle' Setting 2 = 18 l/s (65m ³ /h)	power consumption 3.0W	- floor area up to 130m ² .
'Trickle' Setting 3 = 26 l/s (94m ³ /h)	power consumption 4.0W	- floor area up to 187m ² .
'Trickle' Setting 4 = 34 l/s (122m ³ /h)	power consumption 5.0W	- floor area up to 245m ² .
'Trickle' Setting 5 = 42 l/s (151m ³ /h)	power consumption 7.0W	- floor area up to 302m ² .

Maximum motor power 13W

As a guideline the 'Normal' speed setting should be the 'Trickle' speed setting plus three, however as every house is unique, this is not always the case, in some houses the 'Normal' speed may need to be more or less than the guideline speed.

'Normal' Setting 1 = 10 l/s (36m³/h).

'Normal' Setting 2 = 18 l/s (65m³/h).

'Normal' Setting 3 = 26 l/s (94m³/h).

'Normal' Setting 4 = 34 l/s (122m³/h) - To be used when 'Trickle' Setting 1 is set.

'Normal' Setting 5 = 42 l/s (151m³/h) - To be used when 'Trickle' Setting 2 is set.

'Normal' Setting 6 = 50 l/s (180m³/h) - To be used when 'Trickle' Setting 3 is set.

Note: Figures based on a 2.4m ceiling height.

The factory setting is "Trickle" Setting 2 and "Normal" setting 5.

In many installations where condensation is a severe problem; it is recommended to run the fan at high speed for a couple of weeks to ventilate the house thoroughly.

This can be achieved by utilizing the LS input option, whereby the unit will run on Purge setting until the LS signal is terminated. To achieve this, connect the LS core of the integral mains flying lead to an LS input.

It is the responsibility of the installer to ensure that appropriate speeds are selected.

F. SERVICING AND MAINTENANCE.

The fan motor uses sealed ball bearings and does not require further lubrication. Apart from filter change the Lo-Carbon PoziDry contains no user serviceable parts.

Under normal conditions; i.e. away from main roads and industrial areas; it is recommended that the filter is checked annually and cleaned or replaced as necessary. Otherwise change as required.

The filter may be gently cleaned with a vacuum cleaner or washed in a soapy water solution and allowed to air dry before re-fitting. Do not dry in a tumble dryer.

Spare filter packs are available from Vent-Axia Sales Centres.

Spares and Accessories	Part Number
FILTER PACK	
ANTI-VIBRATION FEET SET	
HANGING CABLE SET	
90 degree BEND dia 200	
1.5 m dia 200 DUCT	

G. FAULT FINDING.

The Lo-Carbon PoziDry has built in fault detection software to ensure continual safe functioning.

If one of the following faults appears on the LCD display please contact Technical Support on 0844 8560594.

F1 = Open circuit thermistor i.e. not connected.

F2 = Short circuit thermistor i.e. wires, PCB or thermistor shorted.

The above codes are mutually exclusive so cannot occur at the same time.

F3 = Motor Tachometer signal failure or fan not rotating.

F4 = Motor AND open circuit thermistor failures.

F5 = Motor AND short circuit thermistor failures.

Note that if the unit is hanging the display is upside down.

Vent-Axia®

Head Office: Fleming Way, Crawley, West Sussex, RH10 9YX. Tel: 01293 526062 Fax: 01293 551188

UK NATIONAL CALL CENTRE, *Newton Road, Crawley, West Sussex, RH10 9JA*

SALES ENQUIRIES: Tel: 0844 8560590 Fax: 01293 565169

TECHNICAL SUPPORT: Tel: 0844 8560594 Fax: 01293 539209

For details of the warranty and returns procedure please refer to www.vent-axia.com or write to Vent-Axia Ltd, Fleming Way, Crawley, RH10 9YX