

Vent-Axia[®]

Long Case Axial Fan

Installation and Wiring Instructions

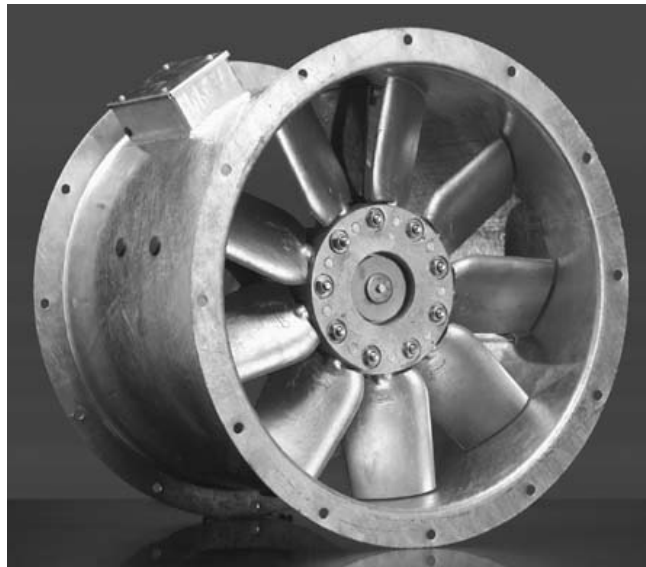

220-240V/1/50Hz & 380-415V/3/50Hz

*READ INSTRUCTIONS IN CONJUNCTION WITH ILLUSTRATIONS
PLEASE SAVE THESE INSTRUCTIONS*



**IMPORTANT:
READ THESE INSTRUCTIONS BEFORE COMMENCING THE INSTALLATION**

DO NOT install this product in areas where the following may be present or occur:

- Excessive oil or a grease laden atmosphere.
- Corrosive or flammable gases, liquids or vapors.
- Ambient temperatures less than -5°C or higher than 54°C .
- Relative humidity above 95%
- Possible obstructions which would hinder the access or removal of the fan.
- Sudden ductwork bends or transformations close to the fan.

SAFETY AND GUIDANCE NOTES

Air moving equipment may present mechanical, electrical or noise hazards. To minimise the risks associated with these potential hazards, it is essential that installation, operation and maintenance instructions are followed and carried out by a suitably qualified person.

- A.** All wiring to be in accordance with the current I.E.E. Regulations, or the appropriate standards of your country.
- B.** The Fan should be provided with a local 2/3 pole isolator switch having a contact separation of at least 3mm.
- C.** Ensure that the mains supply (Voltage, Frequency, and Phase) complies with the rating label.
- D.** The Fan should only be used in conjunction with the appropriate Vent-Axia products.
- E.** It is recommended that the connection to the terminal box is made with flexible cable/conduit.
- F.** The fan should not be sited within 600mm horizontally of/or 2250mm vertically of a bath/shower tray, in accordance with the I.E.E. Regulations for bathrooms.
- G.** When the Fan is used to remove air from a room containing a fuel-burning appliance, ensure that the air replacement is adequate for both the fan and the fuel-burning appliance.
- H.** If the fan is used to supply air into a room, the installer must ensure that the fan intake is located a minimum of 600mm from any flue outlet.
- I.** This fan is designed as an inline ducted fan to be positioned between lengths of ducting. Short duct runs terminating within 1.5m must incorporate suitable guards.
- J.** Certain applications may require the installation of sound attenuation material, together with either an Auto Transformer or Inverter Speed Controller to achieve the sound levels required.

DESCRIPTION.

The Long Case Axial range of fans incorporates factory adjustable pitch impellers, which provide a comprehensive range of duties offering high performance and pressure characteristics. Available in twelve sizes ranging from 315mm to 1250mm \varnothing and performances from $0.24\text{m}^3/\text{s}$ to $38\text{m}^3/\text{s}$ with a pressure development up to 1250Pa. The casing is constructed from rolled steel plate and protected with a galvanised finish.

A. INSTALLATION.

1. Ensure the impeller rotates and is free from obstruction, prior to installation.
2. The fan is suitable for mounting at any angle.
3. Ensure that there is adequate clearance for accessing the fan.
4. Securely mount the fan using the holes in the end flanges and use the appropriate drop rods, bolts, anti-vibration mountings etc.
5. Ensure the Airflow Arrow is aligned with the direction of the airflow required.
6. The use of flexible connections and anti-vibration mountings is recommended to minimise noise and vibration.
7. Ensure that the flexible connections are taut and the fan and ductwork are aligned.
8. Flexible connections **MUST** be used in conjunction with anti-vibration mountings.
9. Anti-vibration mountings must be installed in compression.

Fig. 1. TYPICAL INSTALLATION (Horizontal).

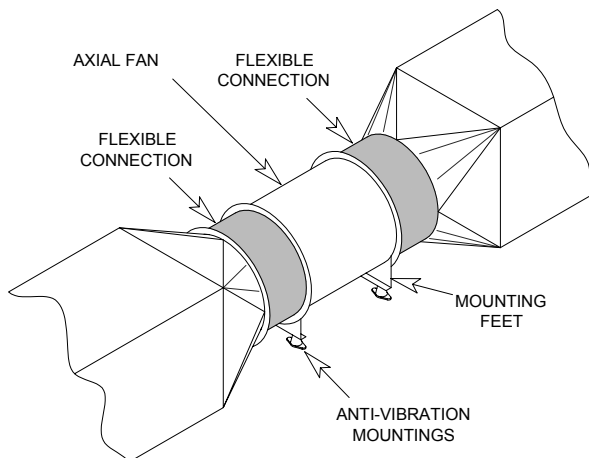

WIRING



WARNING: THE FAN AND ANCILLARY CONTROL EQUIPMENT MUST BE ISOLATED FROM THE POWER SUPPLY DURING THE INSTALLATION / OR MAINTENANCE. THE EQUIPMENT MUST BE EARTHED

1. Select and follow the appropriate wiring diagram (Figs. 2-11).
2. Check all connections have been made correctly and ensure that all terminal connections and cable clamps are securely fastened.
3. The cable entry must be made using a suitable grommet or cable gland.
4. Switch the mains power supply on and check the fan is operating correctly.

Fig. 2. Single Phase Fan Connected to a 240V D.O.L. Starter.

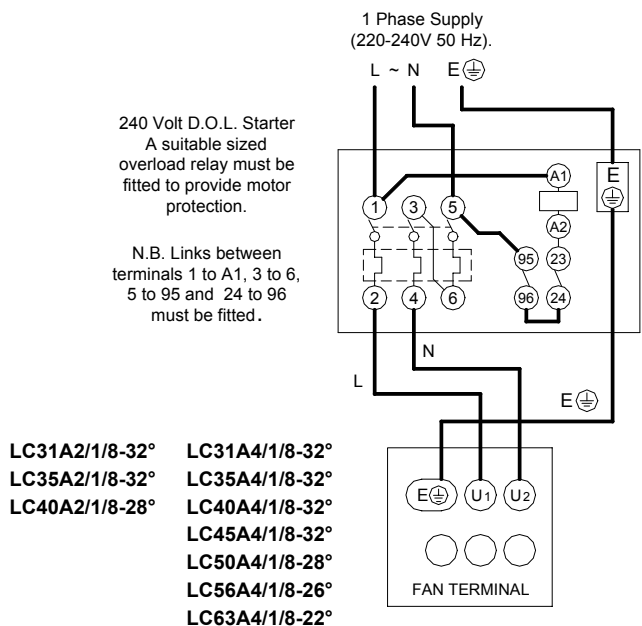

- LC31A2/1/8-32°
- LC35A2/1/8-32°
- LC40A2/1/8-28°
- LC31A4/1/8-32°
- LC35A4/1/8-32°
- LC40A4/1/8-32°
- LC45A4/1/8-32°
- LC50A4/1/8-28°
- LC56A4/1/8-26°
- LC63A4/1/8-22°

Fig. 3. Single Phase Fan Connected to a 240V D.O.L. Starter an Auto Transformer Speed Controller.

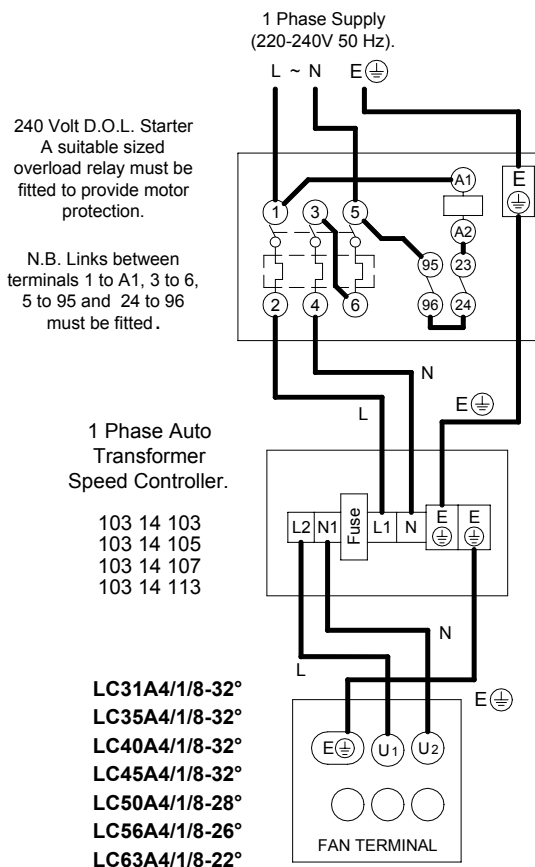

- LC31A4/1/8-32°
- LC35A4/1/8-32°
- LC40A4/1/8-32°
- LC45A4/1/8-32°
- LC50A4/1/8-28°
- LC56A4/1/8-26°
- LC63A4/1/8-22°

Fig. 4. Three Phase Fan Connected to a 415V D.O.L. Starter.

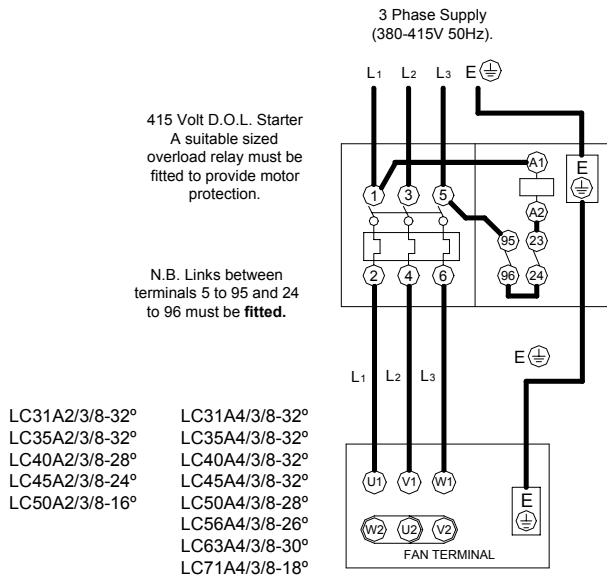

Fig. 5. Three Phase Fan Connected to a Star / Delta Starter.

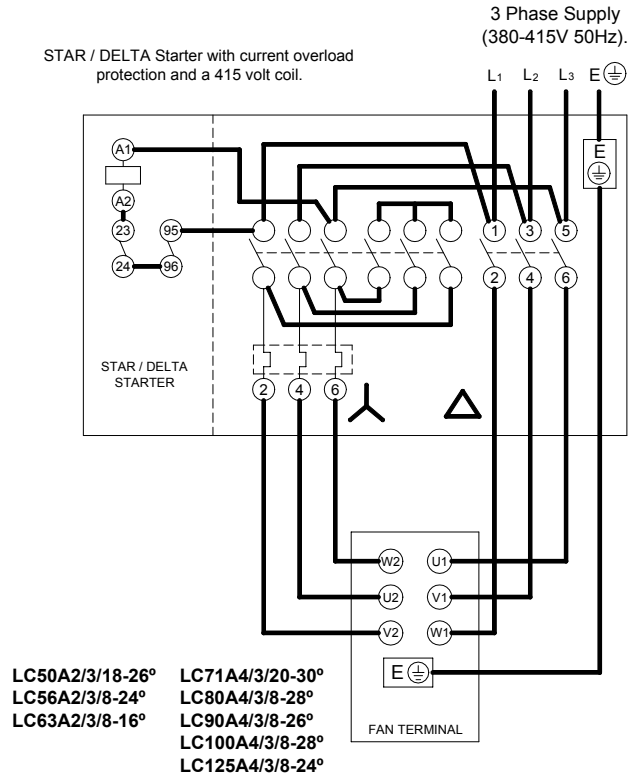
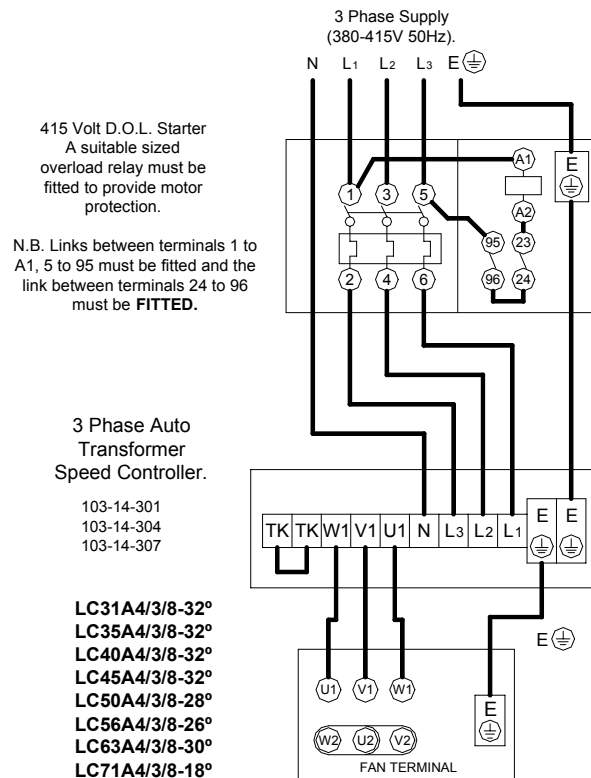
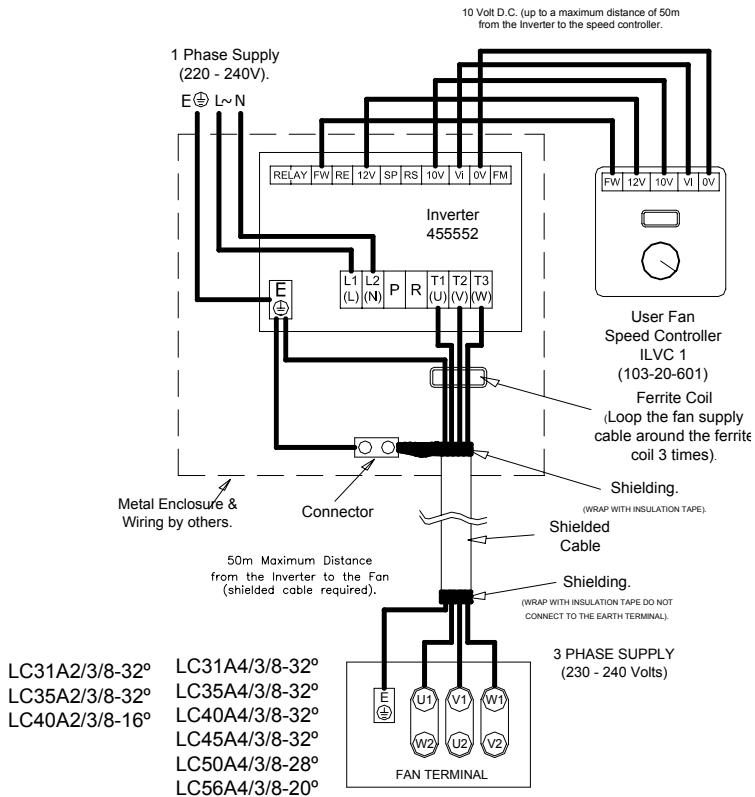

Fig. 6. Three Phase Fan Connected to a 415V D.O.L. Starter and an Auto Transformer Speed Controller.



NOTE: If an Auto Transformer is being used to control the Fan speed, the reset facility **MUST** be disabled.
 Contact Vent-Axia's Technical Support Line for details.

**Fig. 7. Three Phase Fan
Single Phase in – Three Phase (240V) Out
LC Fan connected to an Inverter Speed
Controller Kit (103 20 101).**



**Fig. 8. Three Phase Fan
Single Phase in – Three Phase (240V) Out
LC Fan connected to an Inverter Speed
Controller Kit (103 20 102 or 103 20 103).**

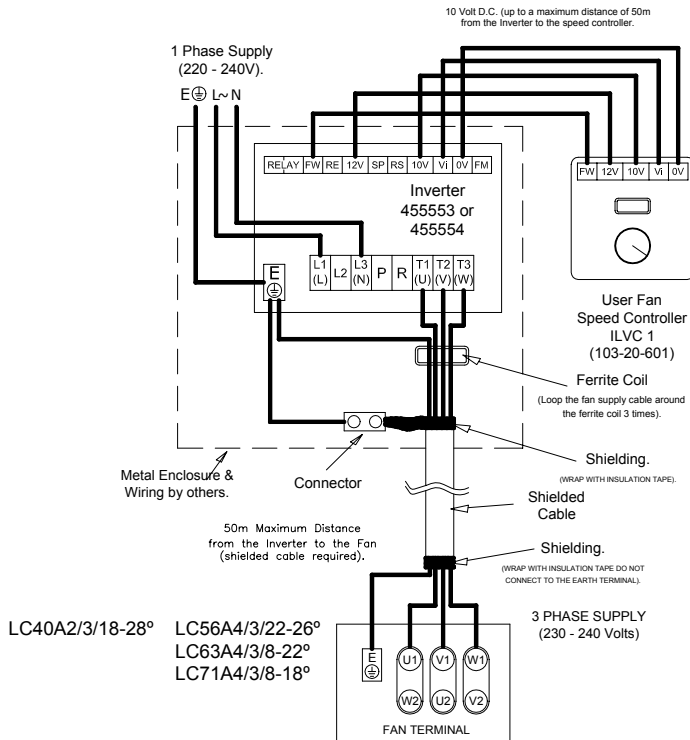

**Fig. 9. Three Phase Fan.
Three Phase In – Three Phase Out. LC Fan connected to an Inverter Speed Controller Kit
(103 20 301, 103 20 302, 103 20 303 or 103 20 305).**

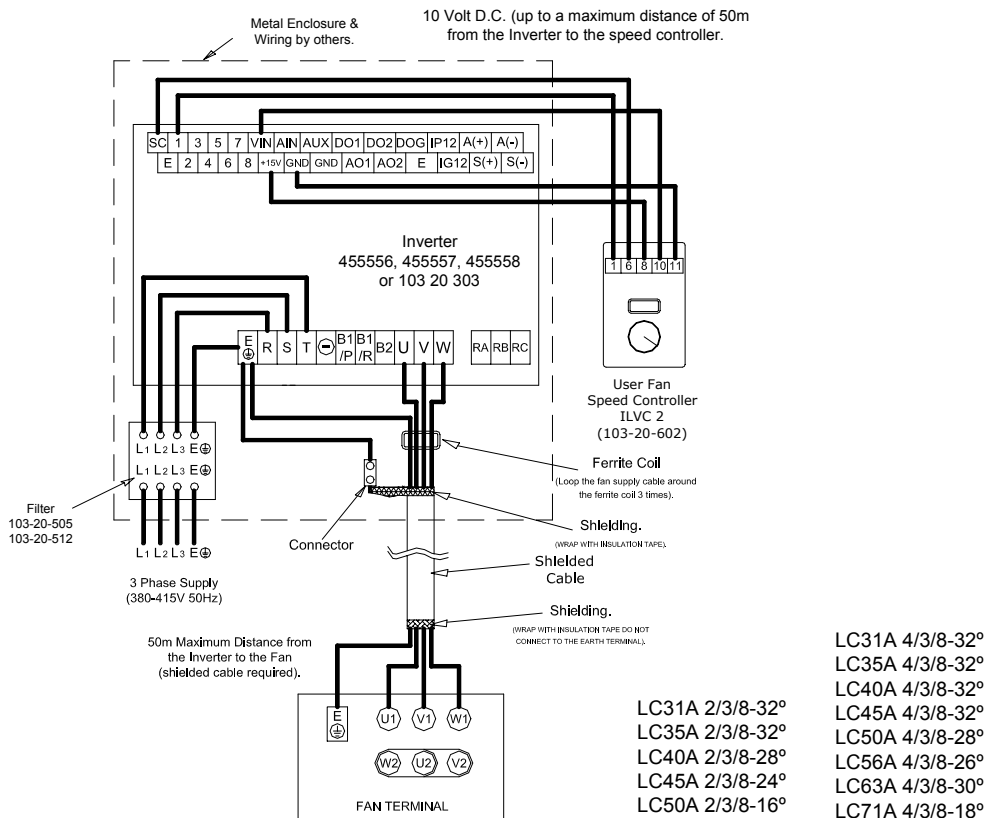

Fig. 10. Three Phase Fan.
Three Phase In – Three Phase Out. LC Fan connected to an Inverter Speed Controller Kit
(103 20 350 or 103 20 310).

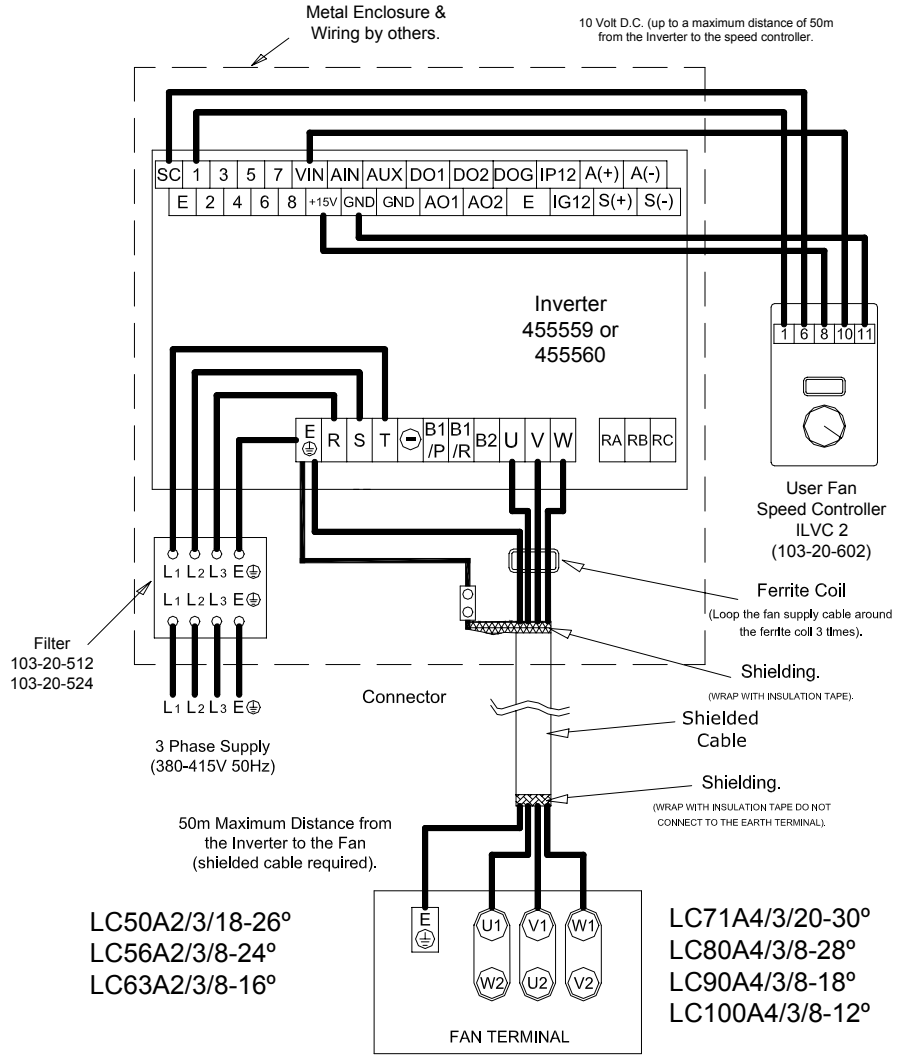
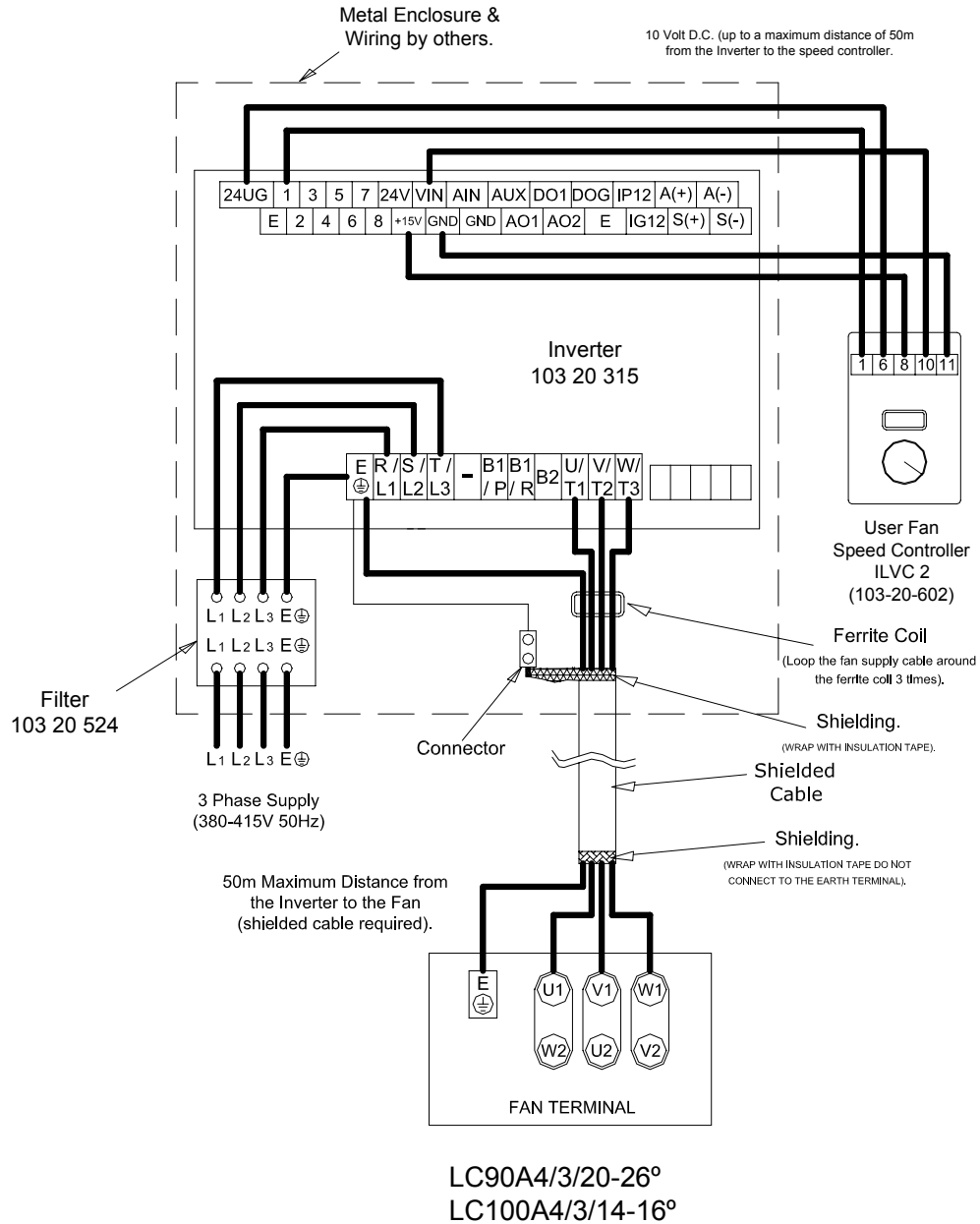

Fig. 11. Three Phase Fan.

Three Phase In – Three Phase Out. LC Fan connected to an Inverter Speed Controller Kit (103 20 315).



ROUTINE INSPECTION AND MAINTENANCE

ISOLATE FROM THE POWER SUPPLY AND ENSURE THAT THE FAN CANNOT BE ACCIDENTALLY SWITCHED BACK ON.

1. At intervals appropriate to the installation, the fan should be inspected and cleaned to ensure there is no build up of dirt or other deposits on the impeller or motor. If the fan is handling dust laden air, it is recommend that a filter is installed.
2. All Case Axial fans have sealed for life bearings and do not require lubrication.
3. Check the condition and security of all fixing bolts, rods, anti-vibration mountings, and flexible connections.

VENT-AXIA SALES CENTRES

ENGLAND & WALES NATIONAL CALL CENTER

Newton Road, Crawley
West Sussex
RH10 9JA

Telephone: 01293 530202
Fax: 01293 565169

NORTHERN IRELAND

Telephone: 02890 402220
Fax: 01293 565169

SCOTLAND

Telephone: 0141 429 1166
Fax: 01293 565169

REPUBLIC OF IRELAND

Vent-Axia Ventilation Ltd.
921 Western Road Industrial Estate
Naas Road, Dublin 12.

Telephone: (01) 450 4133
Fax: (01) 450 4570

Did you find these instructions easy to use?

We value your comments, contact us via :

Email: info@vent-axia.com

The Vent-Axia Guarantee

Applicable only to products installed and used in the United Kingdom. For details of the Guarantee outside of the United Kingdom contact your local supplier.

Vent-Axia guarantees this product for two years from the date of purchase against faulty material or workmanship. In the event of any part being found to be defective, the product will be repaired, or at the Company's discretion the product will be replaced without charge, provided that the product:

- 1). Has been installed and used in accordance with the instruction given with each unit.
- 2). Has not been connected to an unsuitable electricity supply (The correct electricity supply voltage shown on the product-rating label attached to the unit).
- 3). Has not been misused, neglected or damaged.
- 4). Has not been modified or repaired by any person not authorised to do so by Vent-Axia.

IF CLAIMING UNDER THE TERMS OF THE GUARANTEE

Please return the complete product, carriage paid to your original supplier by post or in person. Please ensure that it is adequately packed and accompanied by a letter clearly marked 'Guarantee Claim' stating the nature of the fault and providing proof of the date and source of purchase.

As part of the policy of continuous product improvement Vent-Axia reserve the right to alter specifications without notice

Vent-Axia®

Head Office: Fleming Way, Crawley, West Sussex RH10 9YX
Tel: 01293 526062 Fax: 01293 551188
Internet site at: www.vent-axia.com

DECLARATION OF CONFORMITY

Vent-Axia Ltd.
Newton Road
Crawley,
West Sussex,
RH10 9JA

EC DECLARATION OF CONFORMITY.

Here with we declare that the air movement equipment designated below, on the basis of its design and construction in the form brought onto the market by us in accordance with the relevant safety and health requirements of the EC Directive on Machinery.

If alterations are made to the machinery without prior consultations with us, this declaration becomes invalid.

DESIGNATION OF EQUIPMENT: VENTILATION FAN.

SERIES TYPE: LONG CASE AXIAL FAN.

Applied Authorisation Standards ⁽¹⁾
in particular: EN 292-1, EN 292-2, EN294
EN 50081-2, EN 60204-1.

Applied National Standards and
Technical Specifications ⁽²⁾
in particular: BS 848 Part 1,
BS 848 Part 2,
BS 848 Part 3.

Basis of self attestation Working to
Quality Assurance: BS EN ISO 9001

Signatory:



R.D.A Spearman.
Product Director.

Place / Date Crawley – April 2003

Notes: 1. For the complete list of applied standards and technical specifications see
Vent- Axia Ltd. Documentation.
2. Where no relevant harmonised standards exist.