

Wall or Ceiling Mounted Halogen Quartz Infrared Heater

INSTRUCTION MANUAL

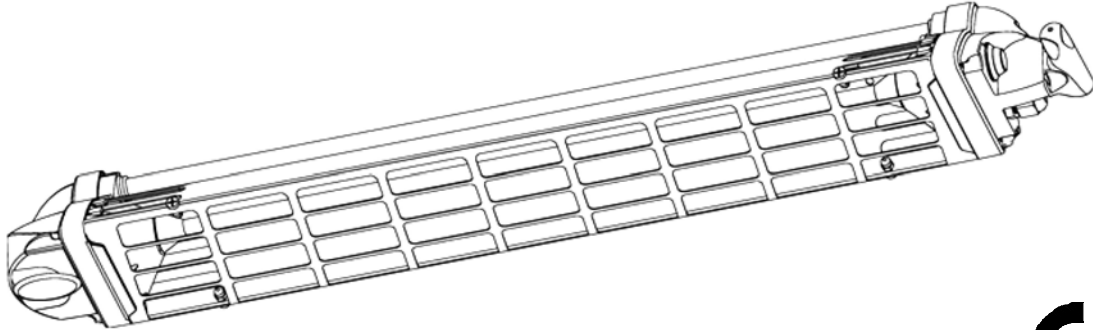

PLEASE READ AND SAVE THESE INSTRUCTIONS

IMPORTANT: READ THESE INSTRUCTIONS BEFORE COMMENCING THE INSTALLATION



SAFETY AND GUIDANCE NOTES

1. This appliance is intended solely for the use it has been designed. The Manufacturer is not responsible for any damage that could happen for improper use.
2. After unpacking make sure that the appliance is complete and shows no signs of visible damage or tampering.
3. Keep packing materials, which are potential dangers, away from children.
4. The appliance is not suited for persons (as well as children) physically, mentally, sensory disabled, or with no experience, unless they have been supervised or directed by someone responsible for their safety.
5. Do not let children play with the appliance.
6. Ensure that the mains supply (voltage, frequency, and phase) complies with the heaters rating label.
7. Do not use in presence of gas, inflammable or explosive liquids or substances.
8. Some fundamental rules which apply to all electrical devices must be observed when using the heater:
 - Do not touch the heater with wet hands.
 - Do not pull the electric cord or the device itself to unplug it from the socket.
 - Do not let children play with the electrical appliance.
9. Avoid the use of an extension cords with this product, because the extension cord may overheat and cause a risk of fire.
10. Do not apply any modification to the product that could compromise the safety.
11. Keep connections dry.
12. If the appliance is not used for a long period, disconnect it from the power supply.
13. Always disconnect the appliance before doing any maintenance.
14. If the power cord is damaged, Do not use the appliance, contact a suitably qualified person to replace the cord.

INSTALLATION OF THE APPLIANCE

Installation should always be carried out by a qualified electrician or a competent person in accordance with the current I.E.E regulations, or the appropriate standards of your country. The supply must be done through a properly earthed socket.



A circuit breaker with contact separation distance of at least 3 mm must be fitted upstream from the supply.

- The heaters should always be installed horizontally only using the mounting brackets supplied. This ensures correct positioning and adequate clearance.
- A minimum air gap of 400mm should always be allowed between the top of the heater and a ceiling or roof. The appliance should be 600mm away from the walls (fig.1).
- Be sure that the heater is not facing the ceiling or inflammable substances.
- A safety distance of not less than 1000mm should always be left in front of the heater.
- This unit should be mounted at a minimum of 1800 mm above ground level (fig.1). If installed in a toilet, the height should be 2250 mm in zone 1 and zone 2; in zone 3 the minimum above ground level is 1800 mm, according with the rules of each Country.
- The appliance must not be located directly below a wall socket.
- The heater must be installed to prevent the switches being touched by people using a shower.
- Do not use the heater directly near a bathtub, a shower, a swimming pool.
- Ensure that there is no possibility of inflammable material coming into contact with the heater, or lies near the heater.
- Heaters should not be installed in areas where hazardous vapours may be present. Defined in BS5345.
- The heaters are fitted with safety guards. These are intended only to stop large objects from hitting the emitters. On no account should the heater be operated with the guard removed.

The heat generated by the heater reaches a distance of about 3 meters in front of the appliance. The lamp in the heater is a halogen filled quartz linear lamp with a tungsten element. The tungsten element operates at about 2,200 degrees centigrade and is housed in a quartz sleeve to filter out the white light and emit short wave infrared radiant heat. The heater operates at full output almost immediately and emits a radiant energy with a wavelength of 1.2 microns.

ELECTRICAL INSTALLATION

The heaters power rating is 1800 watt.

- The heaters are fitted with high temperature silicone rubber flexible cable (H05 RN-F) conforming to BS 6500. Connect the brown wire to Live (L), Connect the blue wire to Neutral (N), & Connect the green/yellow wire to Earth.
- Before pressing the switch, hold the grip on the side and avoid touching the metal parts.
- The product is a class I appliance and is rated at IP65, so the heater may be used outdoors.
- For keeping the IP protection rate of the appliance, the connection of the appliance with the power supply must be done by means of a minimum IP65 system, as per the standards HD 384 CENELEC for Europe, or international IEC 60346-7-708 1988.

LOCATION

Wall Mounting

- A mounting bracket is provided with the heater which has been specifically designed to allow this product to be fitted to a wall. Before drilling the holes for the wall plugs and screws, be sure that the wall is solid and that there are no hidden water pipes or electrical wires.

Hold the bracket up against the wall and mark through the 4 fixing hole positions drill four holes with a 5 mm diameter drill bit and fix the wall bracket with the wall plugs and screws provided (fig.2).

Then fix the appliance to the wall bracket using the 2 screws and the 2 half rings (fig.2).



Ceiling Mounting

- A chain suspension kit is provided for ceiling mounting. Before drilling the holes for the ceiling fixings, be sure that the ceiling is solid and that there are no hidden water pipes or electrical wires.

Fix the ceiling fixings into the ceiling at a distance of about 55 cm. Fix the 4 half rings around the pipe on the appliance, being sure that the chain is fixed with the screws (fig.3). The 4 half rings should be at the opposite ends of the pipe, for the best stability. Ensure that the chains are securely mounted as this application is designed for overhead use.

IMPORTANT: Ensure that the supply cable is well mounted and that it does not come into contact with the reflector of the heater or that it does not trail into the heated area. The supply cable can be fixed to the metal pipe behind the reflector with plastic wrappers.

COMMISSIONING

- Switch on heater and confirm that the lamp is operating.
- Ensure that the heater is aiming its warmth into the target area by adjusting heater angle as necessary by using the adjustment device on the bracket, after you have loosed the screws of the half rings (See diagram opposite)

All users should be made aware of all aspects of operation and safety and these instructions should be retained for future reference.

- In unoccupied premises it is recommended that the heating system is switched off and isolated from the electrical supply.

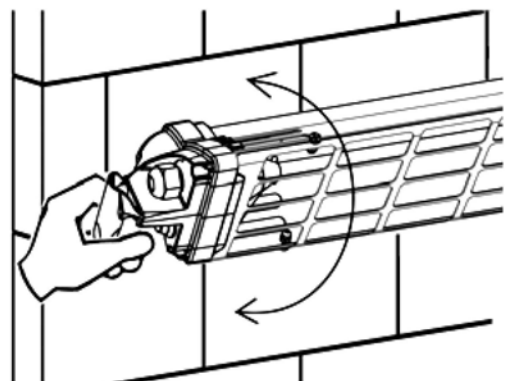

MAINTENANCE



Warning

The Heater must be isolated from the power supply and allowed to cool down before any cleaning and maintenance takes place.

The IR Industrial Heaters contain no moving parts and therefore very little maintenance is required other than to ensure that there is no excessive build-up of dust/dirt on the reflectors or lamps as this can cause overheating and premature lamp failure. To clean the appliance, wipe off with a damp cloth. Wait until it is completely dry before re-connecting to the power supply.

LAMP & SILICONE BUMPERS REPLACEMENT

The lamps used in the IR heater are robust and if knocks and shock vibrations are avoided, they will last for around 5000 hours. When changing the lamp, also the silicon bumpers connected with the lamp must be substituted. They should be substituted even before if there are signs of aging. Due to the special sealing and anti-shock design of the heater, the lamps are not intended to be user replaceable. Please ensure that all lamps are replaced by a suitably qualified electrician / Service engineer.



This product conforms to EU Directive 2002/96/EC.

This appliance bears the symbol of the barred waste bin. This indicates that, at the end of its useful life, it must not be disposed of as domestic waste, but must be taken to a collection centre for waste electrical and electronic equipment. It is the user's responsibility to dispose of this appliance through the appropriate channels at the end of its useful life. Failure to do so may incur the penalties

established by laws governing waste disposal. Proper differential collection, and the subsequent recycling, processing and environmentally compatible disposal of waste equipment avoids unnecessary damage to the environment and possible related health risks, and also promotes recycling of the materials used in the appliance. For further information on waste collection and disposal, contact your local waste disposal service, or the shop from which you purchased the appliance.

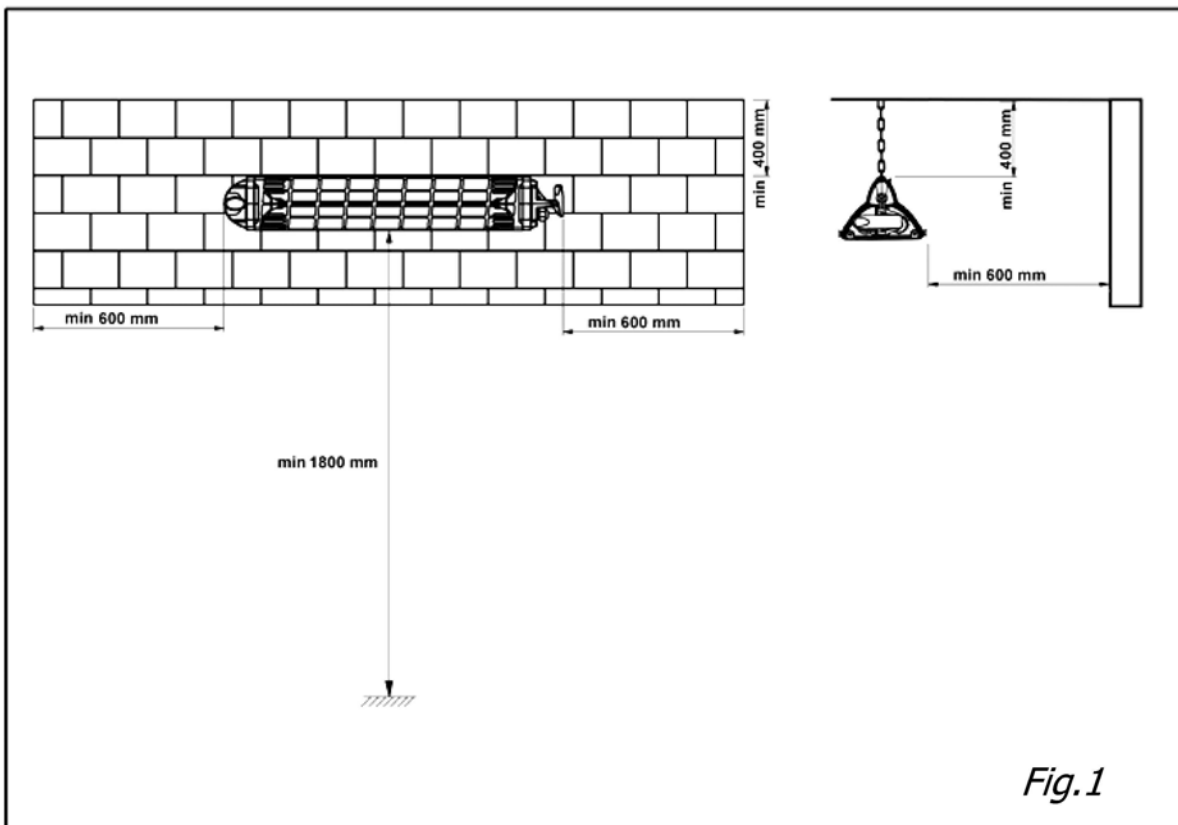

Fig.1

