

Centra Lo-Carbon SELV

CONTINUOUS EXTRACT FAN

Installation and Wiring Instructions



Stock Ref. N°

- 44 31 74 - Constant Volume
- 44 31 75 - Timer (**T**)
- 44 31 76 - Humidistat-Timer (**HT**)
- 44 31 77 - Humidistat - Timer - Pullcord. (**HTP**)
- 44 71 28 - Timer-Pullcord (**TP**)

FAN UNITS 12V DC SELV (CLASS III)
CONTROLLERS 220-240V 50Hz MAINS SUPPLY (CLASS II)
WITH 12V DC SELV OUTPUT

Vent-Axia®

PLEASE READ INSTRUCTIONS IN CONJUNCTION WITH ILLUSTRATIONS.
PLEASE SAVE THESE INSTRUCTIONS.

IPX7
CE

Installation and Wiring Instructions for the Centra Lo-Carbon SELV Range of Extractor Fans.



IMPORTANT: READ THESE INSTRUCTIONS BEFORE COMMENCING THE INSTALLATION

DO NOT install this product in areas where the following may be present or occur:

- Excessive oil or a grease laden atmosphere.
- Corrosive or flammable gases, liquids or vapours.
- Ambient temperatures higher than 40°C or less than –5°C.
- Possible obstructions which would hinder the access or removal of the Fan.

SAFETY AND GUIDANCE NOTES

- A. All wiring to be in accordance with the current I.E.E. Regulations, or the appropriate standards of your country and **MUST** be installed by a suitably qualified person.
- B. The Fan should be provided with a local isolator switch capable of disconnecting all poles, having a contact separation of at least 3mm.
- C. Ensure that the mains supply (Voltage, Frequency, and Phase) complies with the rating label.
- D. The Fan should only be used in conjunction with the appropriate Vent-Axia products.
- E. The fan should only be used in conjunction with fixed wiring.
- F. When the Fan is used to remove air from a room containing a fuel-burning appliance, ensure that the air replacement is adequate for both the fan and the fuel-burning appliance.
- G. The Fan should not be used where it is liable to be subject to direct water spray for prolonged periods of time.
- H. Where ducted Fans are used to handle moisture-laden air, a condensation trap should be fitted. Horizontal ducts should be arranged to slope slightly downwards away from the Fan.
- I. This appliance is not intended for use by young children or infirm persons without supervision.
- J. Young children should be supervised to ensure that they do not play with the appliance.
- K. The **exterior** grille should be at least 2.3m above the ground to prevent people from being able to access moving parts. If the **external** grille is positioned between 0-2.3m from the ground, Please use the Vent-Axia wall kit as detailed below to ensure people cannot access the fans impeller from the outside.

IMPORTANT:- ONLY CONNECT TOGETHER PRODUCTS FROM THE CENTRA LO-CARBON SELV RANGE SINCE THE FANS ARE SPECIALLY DESIGNED TO WORK ON 12V DC AND ARE NOT COMPATIBLE WITH OTHER VENT-AXIA CONTROLLERS. DO NOT CONNECT MORE THAN ONE FAN TO THE CONTROLLER.

DESCRIPTION

The Centra Lo-Carbon SELV 100mm fan is a continuously running extract fan for kitchens, utility rooms, bathrooms and toilets.

Long life ball bearing DC motor with anti-vibration mounts provides low noise transmission into plasterboard/panels for silent operation.

The fan can be wall, window or panel/ceiling mounted.

ACCESSORIES (not supplied)

WALL FITTING KIT

A range of white (stock ref. 254102) or brown (stock ref. 254100) 100mm wall kits are available for installing into most walls using telescopic liners supplied.

WINDOW FITTING KIT

A window fitting kit is available (stock ref. 442947).

6" TO 4" ADAPTER PLATE

An adapter to cover up an existing 150mm (6") installation (stock ref. 443334)

A. INSTALLATION

IMPORTANT: The fan should only be used in conjunction with fixed wiring.

SITING THE CONTROLLER

1. The controller must not be installed in a shower cubicle or enclosure. It must be sited away from direct sources of water spray and out of reach (1.5m) of a person using a fixed bath or shower.
2. Site away from direct sources of heat. Ambient temperature range 0 to 40°C. Do not site in an area containing excessive levels of grease.
3. Decide where to site the controller and fan (see section siting the fan), and work out the required cable runs.

SITING THE FAN

1. The electrical supply to this fan is 12V DC SELV from the mains controller. This means that the fan may be installed within reach of a person using a fixed bath or shower, i.e. in a nearby wall. However, the fan must not be placed where it could be submerged in water or regularly exposed to direct water spray, e.g. from a shower head whether permanently fixed or movable.
2. Site away from direct sources of heat. Ambient temperature range 0 to 40°C. Do not site in an area containing excessive levels of grease.
3. If the fan is installed in a room containing a fuel burning appliance the installer must ensure that air replacement is adequate for both the fan and the fuel burning appliance. If the fan is used to supply air into the room the installer must ensure that the fan intake is located at least 600mm away from any flue outlet.
4. Ducted Applications. These fans can be used with short lengths of ducting, but check details first with your Vent-Axia sales centre. Where an excessive amount of moisture is present in the air, a condensation trap will need to be installed in the exhaust duct. Horizontal ducts should slope away from the fan unit. Ducts passing through an unheated roof void should be insulated.
5. A short circuit of the airflow should always be avoided by siting the fan as far away as possible from and opposite to the main source of air replacement. FIG.1

PANEL/CEILING MOUNTING

1. For panel/ceiling mounting the fan should be installed into a closed duct system of at least 1.2m long or protected by an exterior air grille that must comply with the standard requirements of your country to prevent access to the fans impeller.
2. Cut a 105mm diameter hole.
3. Loosen the screw at the bottom of the grille and remove the front grille. Mark the screw centres through the holes in the fan back plate. Drill, plug and screw into position.

4. Attach ducting as required for the installation.
5. Wire the fan as described in Section B-Wiring. Adjust any settings as required (see Section C-Setup).
6. Replace the grille and tighten the retaining screw.
7. After installation, ensure impeller rotates freely.

WALL MOUNTING

1. For wall mounting cut a 117mm diameter hole through the wall and insert the wall sleeve. Slope the sleeve slightly downwards away from the fan. Cut to length and cement both ends into position flush with the wall faces.
2. Loosen the screw in the bottom of the grille and remove the front grille. Mark the screw centres through the holes in the fan back plate. Drill, plug and screw into position.
3. Fix exterior grille into position with the louvres positioned downwards. (Note:- The grille must comply with the standard requirements of your country to prevent access to the fans impeller).
4. Wire the fan as described in Section B-Wiring. Adjust any settings as required (see Section C-Setup).
5. Replace the grille and tighten the retaining screw.
6. After installation, ensure impeller rotates freely.

WINDOW MOUNTING

1. Refer to window kit instructions supplied with the kit.

B. WIRING.



WARNING: THE FAN AND ANCILLARY CONTROL EQUIPMENT MUST BE ISOLATED FROM THE POWER SUPPLY DURING THE INSTALLATION / OR MAINTENANCE.

IMPORTANT

- **The Controller MUST** be surface mounted to allow air to freely circulate around the unit. When installed in a loft void it **MUST NOT** be enclosed or covered with insulation.
- The fan should only be used in conjunction with fixed wiring.
- The cross - sectional area of supply cord used should be ranged from 1 -1.5mm².
- Cable entry can only be made from the rear of the fan.

1. Select and follow the appropriate wiring diagram. (Fig. 2, 3 or 4)
2. Check all connections have been made correctly and ensure all terminal connections securely fastened.
3. Ensure the impeller rotates and is free from obstructions.

C. SETUP



WARNING: THE FAN AND ANCILLARY CONTROL EQUIPMENT MUST BE ISOLATED FROM THE POWER SUPPLY DURING THE INSTALLATION / OR MAINTENANCE.

ACCESSING THE CONTROL SETTINGS – (Fig. 5 and 6)

1. Loosen the screw in the bottom of the grille and remove the front grille.
2. Carefully pull the inner cap from the centre of the fan away from the chassis.
3. Adjust the settings as outlined below.

PLEASE USE THE CORRECT SETTINGS FOR THE RELEVANT MODEL

TRICKLE SPEED SELECTION (6l/s or 9l/s) – (Fig. 8)

In normal running mode the fan can extract at either 6l/s (22m³/h) or 9l/s (32m³/h) flow rate. The fan will boost to 15l/s (54m³/h) when the LS connection is switched.

- Factory set at **6l/s** (22m³/h). (Fig.9)
- Remove jumper connector (JP1) if **9l/s** (32m³/h) extract flow rate is required. (Fig.9)

BOOST SPEED SELECTION (Fig. 9)

(443175 - Timer, 443176 - Humidistat-Timer and 443177 - Humidistat-Pullcord models only)

The fan has two boost speed settings for different installation requirements:

- Max speed: Dip switch 2 in the 'OFF' position. (Fig.10)
- 15l/s speed: Dip switch 2 should be in the 'ON' position. (Factory set) (Fig.10)

Dip switch 1 should be in the 'ON' position for constant trickle mode.

CONSTANT FLOW MODE – enable/disable the digital flow sensor (Fig. 10)

(44 31 74 – Constant Volume model only)

In the majority of applications constant flow mode will not be required, however to turn this feature on, complete the following:

- Push switch (SW1) into the on position to turn on constant flow mode.
- Push switch (SW1) into the off position to turn off constant flow mode. (Factory set)

IMPORTANT – On first power up, the fan will run through its initialisation routine. This will involve the fan running on maximum speed to calibrate each of the constant flow speeds/settings. Once complete (after approx 1-2 minutes), the fan will run as normal and will not need to be initialised/calibrated again. The fan will remember its settings if there is a power cut.

TIMER ADJUSTMENT (T, TP, HT & HTP MODELS) (FIG. 8)

BEFORE ADJUSTING THE TIMER, SWITCH OFF THE MAINS SUPPLY. TIMER SHOULD ONLY BE ADJUSTED BEFORE OR DURING INSTALLATION

IMPORTANT NOTE:- ON THE **TP & HTP** MODELS ONLY THIS ADJUSTS THE OVERRUN TIME FOR THE PULLCORD OPERATION. ON **T & HT** MODELS THE TIMER IS ACTIVATED VIA THE LS CONNECTION.

1. Remove the fan grille. The controller is factory set at 15 minutes approx. The overrun time period can be adjusted from 1-30 minutes by altering the adjuster on the control PCB.
2. To REDUCE the operating time, use a small screwdriver to turn the adjuster Fig.8. CLOCKWISE.
3. To INCREASE the operating time, use a small screwdriver to turn the adjuster Fig.8. ANTI-CLOCKWISE.
4. Replace the fan grille.

HUMIDITY SET-POINT ADJUSTMENT (HT/HTP MODELS) (FIG. 8)

BEFORE ADJUSTING THE CONTROLLER, SWITCH OFF THE MAINS SUPPLY. HUMIDISTAT SHOULD ONLY BE ADJUSTED BEFORE OR DURING INSTALLATION.

1. Remove the fan grille. The controller is factory set to switch on at about 70% RH. The humidity set point can be adjusted from 65-95%RH by altering the adjuster on the control PCB.
2. To LOWER the set-point use a small screwdriver to turn the adjuster Fig.8. ANTI-CLOCKWISE. This makes the controller MORE sensitive.
3. To RAISE the set-point use a small screwdriver to turn the adjuster Fig.8. CLOCKWISE. This makes the controller LESS sensitive.
4. Replace the fan grille.

PULLCORD (TP & HTP MODELS ONLY) – The pullcord activates the inbuilt timer overrun (adjustment settings above). Once activated, the fan will remain on boost for the preset overrun time. If the pullcord is pulled again during the overrun time period, the timer will reset the countdown timer back to the preset value. There is no way of switching the fan back to trickle manually.

D. SERVICING AND MAINTENANCE.



WARNING: THE FAN AND ANCILLARY CONTROL EQUIPMENT MUST BE ISOLATED FROM THE POWER SUPPLY DURING MAINTENANCE.

1. At intervals appropriate to the installation, the fan should be inspected and cleaned to ensure there is no build up of dirt or other deposits.
2. Carefully push the front panel of the grille upwards away from the base part of the grille (fig. 7).
3. Wipe the inlets and front face with a damp cloth until clean.

The fan has sealed for life bearings, which do not require lubrication.

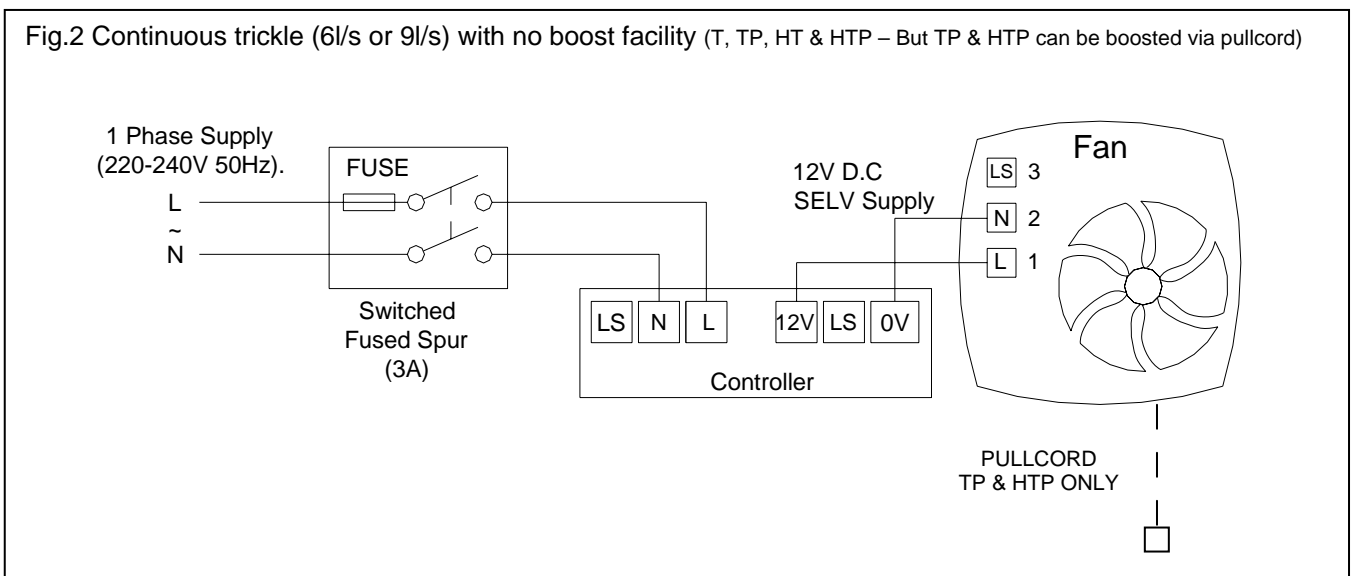
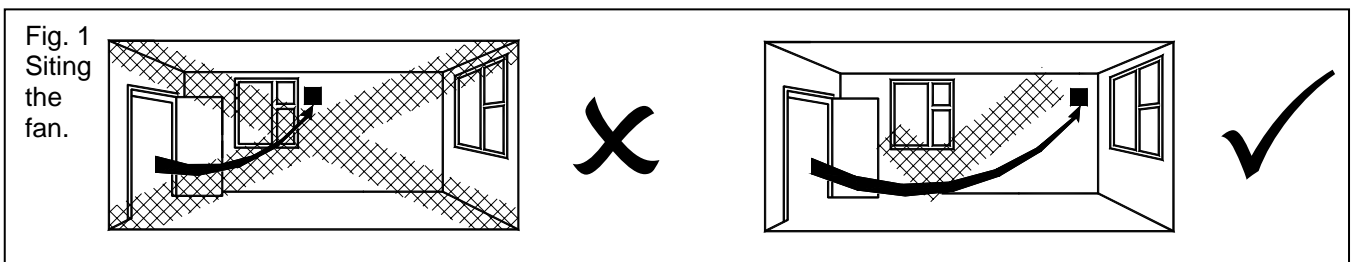

Fig.3 Continuous boost (15/s or Max) with no trickle facility (NOT AVAILABLE ON TP & HTP MODELS)

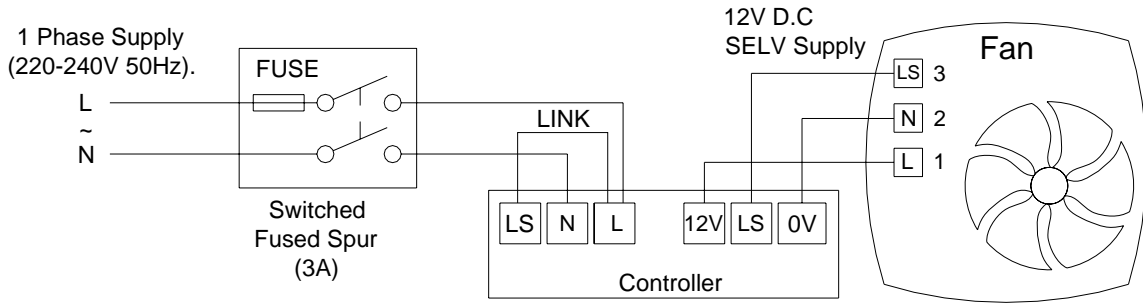

Fig.4 Continuous trickle with boost facility (NOT AVAILABLE ON TP & HTP MODELS)

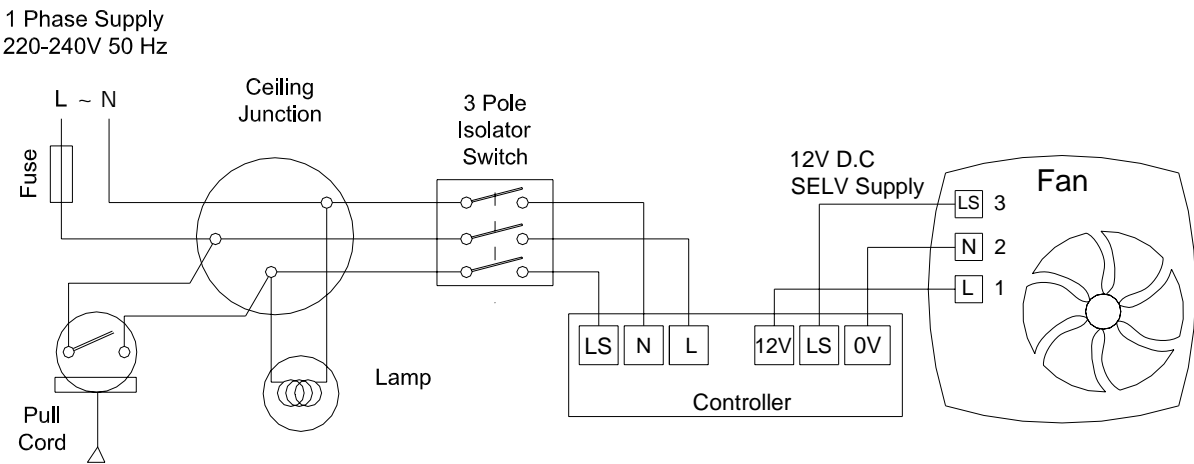
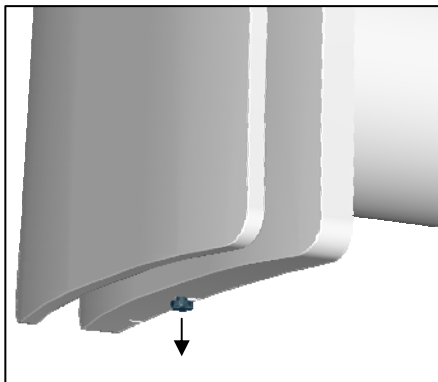
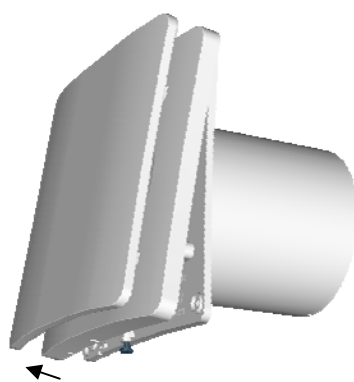

Fig.5. Removing the grille for wiring and setting the controls



1. Loosen screw.



2. Pull grille slightly away from bottom edge.

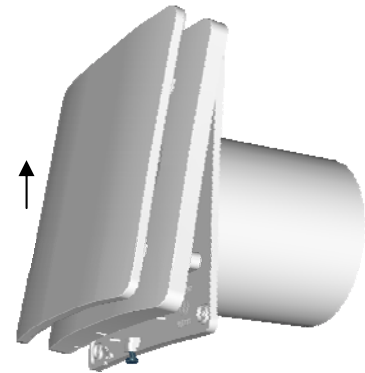

3. Push grille upwards until clear from the fan chassis.

Fig.6. Accessing the control settings

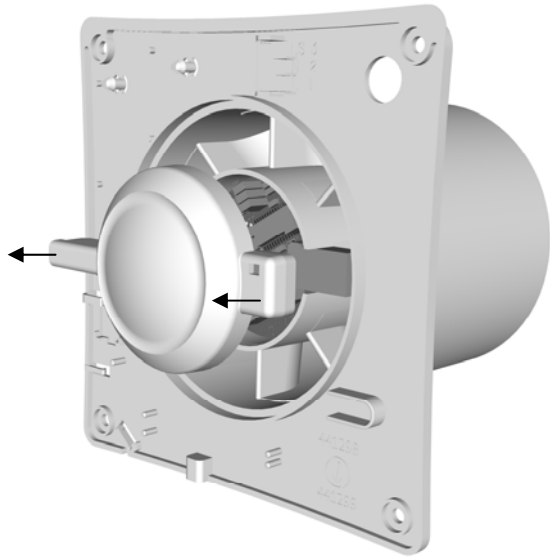

Fig.7. Removing the front grille panel for cleaning.

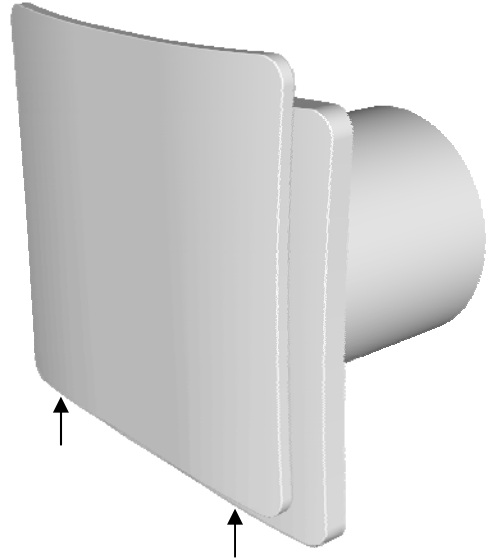
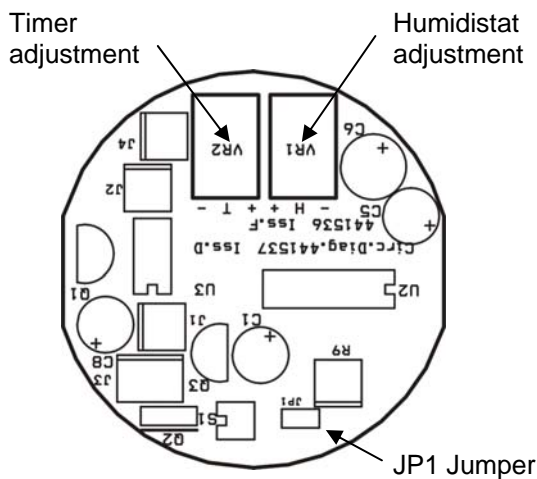
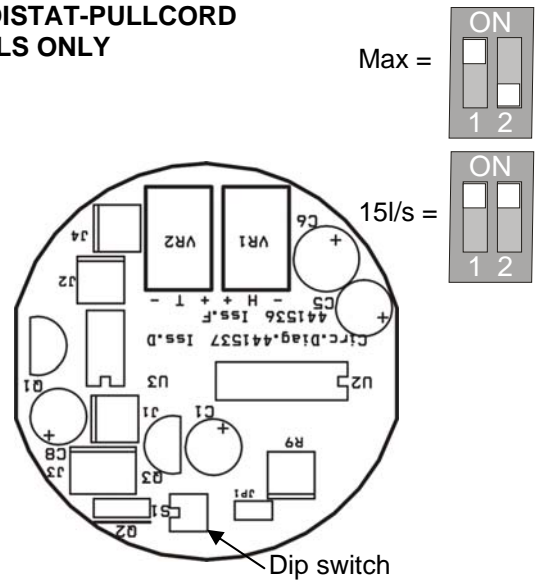

Fig.8. Trickle speed selection and T/HT/HP adjuster pots



9l/s = Remove Jumper Connector
6l/s = Replace Jumper Connector (factory set)

Fig.9. Boost speed selection
**TIMER, HUMIDISTAT-TIMER AND
 HUMIDISTAT-PULLCORD
 MODELS ONLY**



Max speed boost: Dip switch 2 in the 'OFF' position.
15l/s speed boost: Dip switch 2 should be in the 'ON' position.

Fig.10. Constant flow option – using the flow sensor
443174 – CONSTANT VOLUME MODEL ONLY

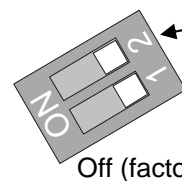
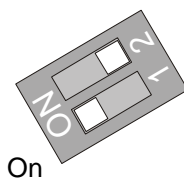
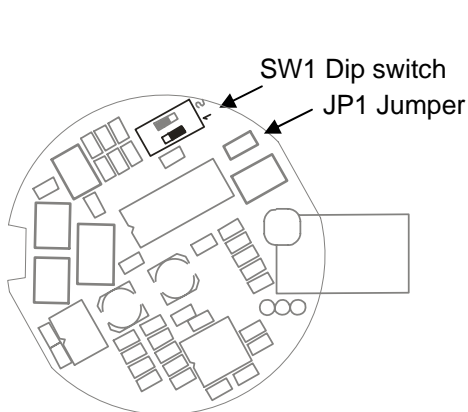

**IMPORTANT:
 DO NOT
 CHANGE DIP
 SWITCH 2.
 LEAVE IN OFF
 POSITION**

Auto sensing mode = Push switch (SW1) into the on position to turn on constant flow mode (enable the digital flow sensor).

Manual mode = Push switch (SW1) into the off position to turn off constant flow mode (disable the digital flow sensor).

The **Vent-Axia** Guarantee

Applicable only to products installed and used in the United Kingdom. For details of guarantee outside the United Kingdom contact your local supplier.

Vent-Axia guarantees its products for two years from date of purchase against faulty material or workmanship. In the event of any part being found to be defective, the product will be repaired, or at the Company's option replaced, without charge, provided that the product:-

- Has been installed and used in accordance with the instructions given with each unit.
- Has not been connected to an unsuitable electricity supply. (The correct electricity supply voltage is shown on the product rating label attached to the unit).
- Has not been subjected to misuse, neglect or damage.
- Has not been modified or repaired by any person not authorised by the company.

IF CLAIMING UNDER TERMS OF GUARANTEE

Please return the complete product, carriage paid to your original supplier or nearest Vent-Axia Centre, by post or personal visit. Please ensure that it is adequately packed and accompanied by a letter clearly marked "Guarantee Claim" stating the nature of the fault and providing evidence of date and source of purchase.

The guarantee is offered to you as an extra benefit, and does not effect your legal rights

Vent-Axia

Head Office: Fleming Way, Crawley, West Sussex, RH10 9YX. Tel: 01293 526062 Fax: 01293 551188

UK NATIONAL CALL CENTRE, Newton Road, Crawley, West Sussex, RH10 9JA

SALES ENQUIRIES: Tel: 0844 8560590 Fax: 01293 565169

TECHNICAL SUPPORT: Tel: 0844 8560594 Fax: 01293 539209

Web:-www.vent-axia.com Email:- info@vent-axia.com

As part of the policy of continuous product improvement Vent-Axia reserves the right to alter specifications without notice.