

Sentinel

Kinetic MVHR & Cooker Hood

User, Installation, Commissioning &
Servicing Instructions

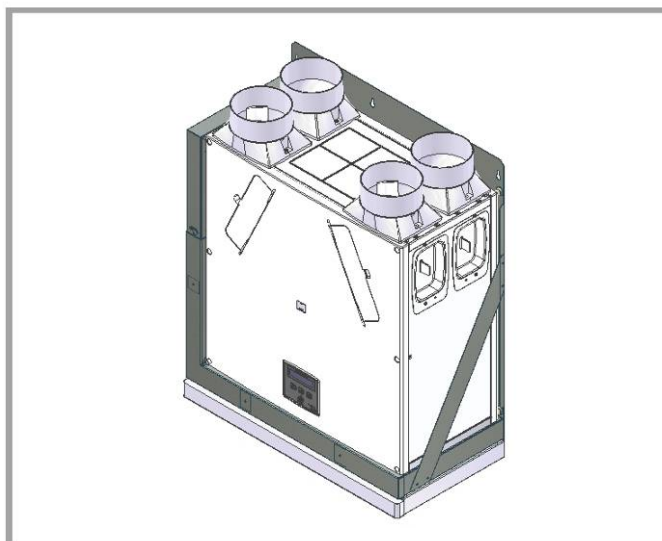

Stock Ref. N°

441483 Kinetic CWL
441484 Kinetic CSL
441485 Kinetic CWR
441486 Kinetic CSR

Read in conjunction with Sentinel Kinetic MVHR Installation &
Commissioning and Operation & Monitoring Documents

Vent-Axia®

PLEASE RETAIN THESE INSTRUCTIONS WITH THE PRODUCT.



IMPORTANT



PLEASE READ THESE INSTRUCTIONS CAREFULLY BEFORE COMMENCING INSTALLATION.

1. READ THE SAFETY INSTRUCTIONS ON PAGE 2 OF THE SENTINEL KINETIC MVHR INSTALLATION & COMMISSIONING AND OPERATION & MONITORING DOCUMENTS
2. IF THE EXTRACTOR HOOD IS INSTALLED IN A ROOM CONTAINING A FUEL-BURNING APPLIANCE, THE INSTALLER MUST ENSURE THAT AIR REPLACEMENT IS ADEQUATE FOR BOTH THE EXTRACTOR HOOD FAN AND THE FUEL-BURNING APPLIANCE.
3. DO NOT CONNECT THE EXTRACTOR HOOD DUCTING TO CHIMNEYS, FLUES OR AIR DUCTS SERVING THE ROOM.
4. DO NOT SITE WHERE AMBIENT TEMPERATURES ARE LIKELY TO EXCEED 50°C. DO NOT DO ANY FLAMBÉ COOKING UNDERNEATH THE HOOD. WHEN FRYING, NEVER LEAVE THE PAN UNATTENDED IN CASE OF FIRE. THIS APPLIANCE IS NOT SUITABLE FOR USE ABOVE AN EYE LEVEL GRILL.
5. **WARNING:** FAILURE TO COMPLY WITH THE CLEANING INSTRUCTIONS MAY RESULT IN A RISK OF FIRE. THE APPLIANCE EFFICIENCY DEPENDS ON THE CONDITION OF THE FILTERS.
6. *All regulations and requirements MUST be strictly followed to prevent hazards to life and property both during and after installation, and during any subsequent servicing and maintenance.*



Disposal

This product should not be disposed of with household waste. Please recycle where facilities exist. Check with your local authority for recycling advice.

Contents

Product Description	4
Sentinel Kinetic MVHR with Cooker Hood	4
User Information.....	5
Technical Specification	6
Sentinel Kinetic with Cooker Hood Technical Specification.....	6
Installation	10
Overview	10
Before Installing the Unit.....	10
Unit Installation.....	10
Fitting the Cooker Hood to the Metal Duct Unit.....	11
Attach Ducting.....	14
Electrical Installation.....	14
Commissioning.....	14
Maintenance.....	15
Caring for the Unit.....	15
Cooker Hood Cleaning Interval	15
Removing Filters.	15
Spares.....	16
Troubleshooting.....	16
Appendix A: Options and Accessories	17
CO2 / Temperature Sensor.....	17
Normal / Boost switch.....	17
Humidistat	17
Wireless Boost Switch.....	17

UK Building Regulations (Part F) Declaration of Conformance

The Sentinel Kinetic conforms to the 2006 Building Regulations (Part F - Means of Ventilation requirements) for installed performance of a ducted mechanical extract fan when installed in accordance with the instructions in this document.

Product Description

Sentinel Kinetic MVHR with Cooker Hood

The Vent-Axia **Sentinel Kinetic Mechanical Ventilation Heat Recovery (MVHR)** unit is a heat recovery unit with a Cooker Hood designed for the energy efficient ventilation of houses and similar dwellings, conforming to the latest requirements of the Building Regulations document F 2006.

In case of a fire or severe overheating on the hob, the unit is fitted with an intumescent fire damper to close the duct as required by BRE Digest 398 and a thermal fuse to switch off the electrical power.

The unit is designed to be mounted in the kitchen above a cooker hob in a standard cupboard space for continuous 24-hour exhaust ventilation of stale moist air from bathrooms, toilets and kitchens. The unit should be switched to boost mode by extending the cooker hood during cooking, or by use of any of the standard switches or sensors. As the stale air is extracted, a heat exchanger within the unit retains up to 90% of the heat and transfers it to the supply air entering the bedrooms and lounge.

Figure 1: Sentinel Kinetic with cooker hood (Right Hand version shown)

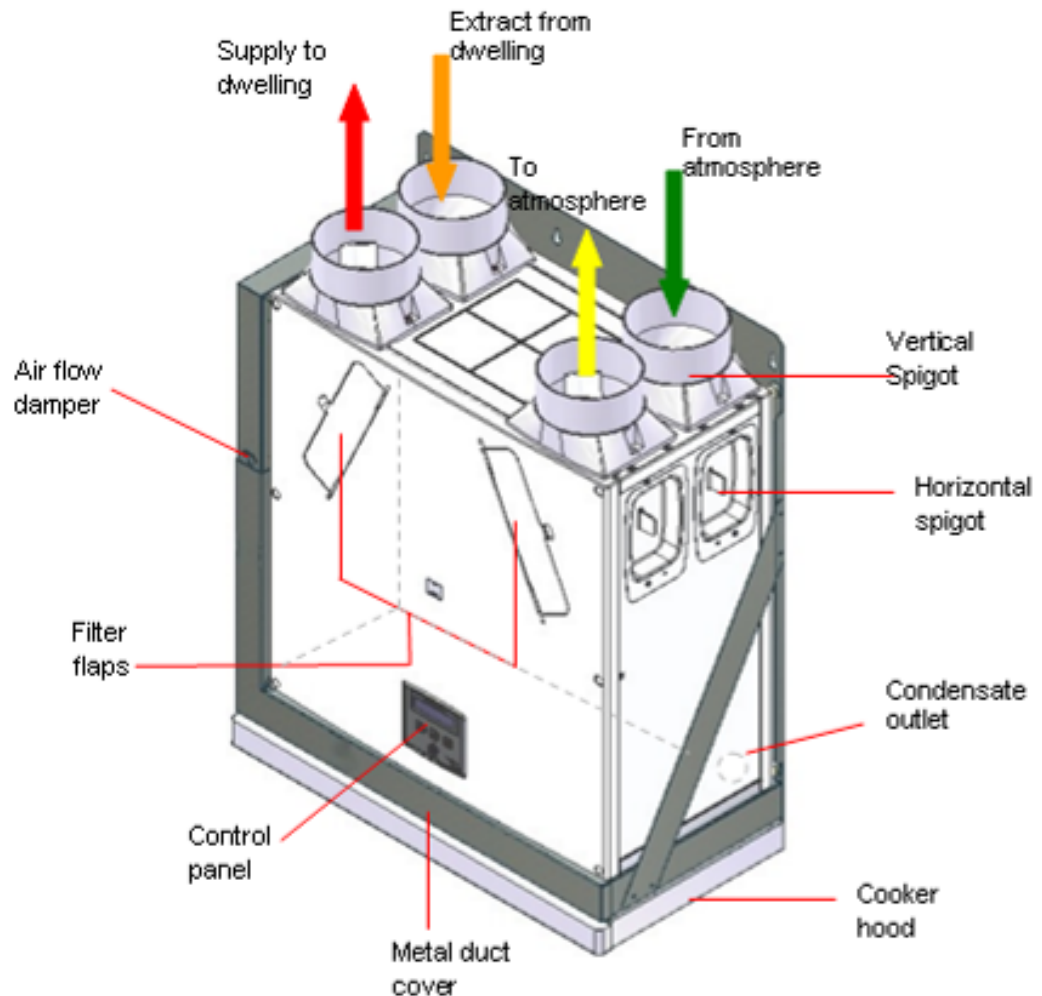

Models

- **441483, 441484, 441485, 441486** - **Sentinel Kinetic with Cooker Hood** and with summer bypass. An internal damper is activated when the outside temperature is equal to, or greater than, the pre-set 'Comfort Temperature' (adjustable between 16 and 30°C). The damper opens allowing cooler fresh air to bypass the Heat Recovery Cell and reduce the internal temperature to the pre-set 'Comfort Temperature'. When the inside air temperature reaches the pre set 'Comfort Temperature' the bypass damper closes. (See page 10 within the Operation & Monitoring leaflet for further information). Note that when the cooker hood is extended the heat recovery cell bypass opens ensuring that grease and other contaminants from cooking do not reduce its efficiency during normal use.

Accessories

- **441838** - Plug-in integral humidity sensor.
- **441865** - Wireless enable kit (consists of wireless receiver and one wireless switch).
- **437827** - Additional wireless switch (up to four may be connected).
- **441780** - Vent-wise accessory pack.
- **443131** – Wired remote control.

A range of sensors can be used to manage system demand and control the ventilation rate. These include an internal humidity sensor, humidity sensors for independent mounting in rooms, wireless receiver and wireless boost switches, CO₂ sensor, manual switches and pull cords. For these alternative control options, see www.vent-axia.com

User Information

Operation of Cooker Hood

The unit is operated in boost mode when the telescopic hood is pulled out. Close it to return the unit to its Normal Flow Rate.

Important Note:

Do not hold on to or place any object on telescopic hood whilst is open, since this can cause damage to its functioning component parts

Operation of Cooker Hood Light

Access can be gained to the light switch when the telescopic hood is opened. The light may be left on with the hood closed if required. However, make sure you switch it off when you have finished using it.

Cleaning Instruction

Refer to page 15 of this document.

Technical Specification

Sentinel Kinetic with Cooker Hood Technical Specification

Performance	
Airflow	Refer to Sentinel Kinetic Installation & Commissioning Document page 5 Flow for cooker hood adjustable using the integral damper.
Sound levels (@ 3 m)	20 dB(A) (normal), 36 dB(A) (boost). Detailed sound spectra available from Vent-Axia.
Power	
AC Voltage Input	220-240 V AC (single phase)
AC Frequency Input	50 Hz nominal
Supply Fuse	3 A (located in fused spur)
Product Fuse	2 A (located on main PCB)
Rated Power	Total 142 W (max.) including (2x11W cooker hood low energy bulbs)
Physical	
Weight	28 kg
Spigot diameter	125 mm
Condensate pipe diameter	22 mm
Environmental	
IP Rating	IP22
Operating Temperature	-10°C to +45°C
Air Intake Temperature	As above
Operating Humidity	0% to 95% RH
Storage Temperature	-10°C to +45°C
Storage Humidity	0% to 95% RH

For all other technical details, please see the Product Catalogue or our website at www.vent-axia.com

Technical Specification

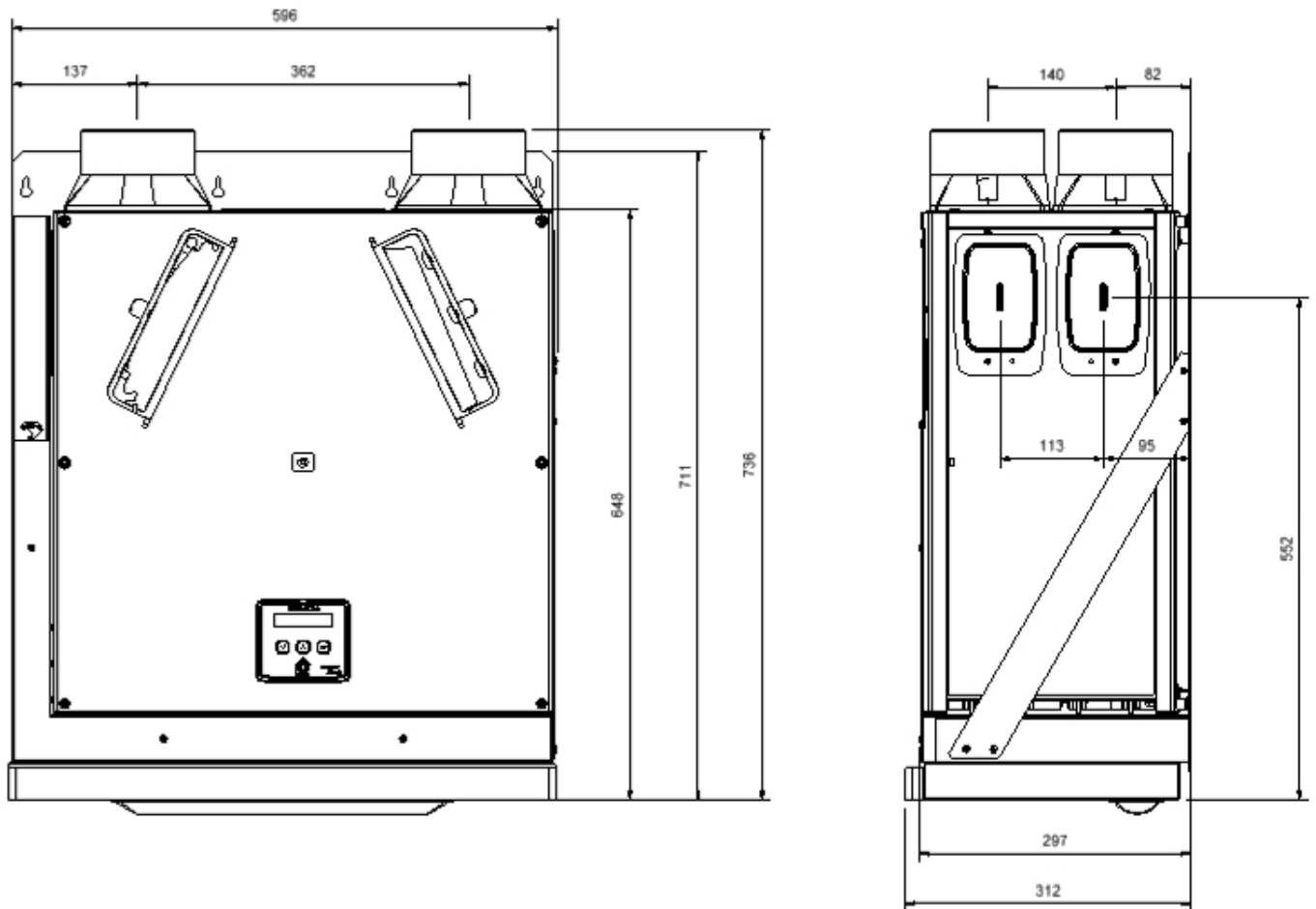

Figure 2: Sentinel Kinetic with Cooker Hood Dimensions

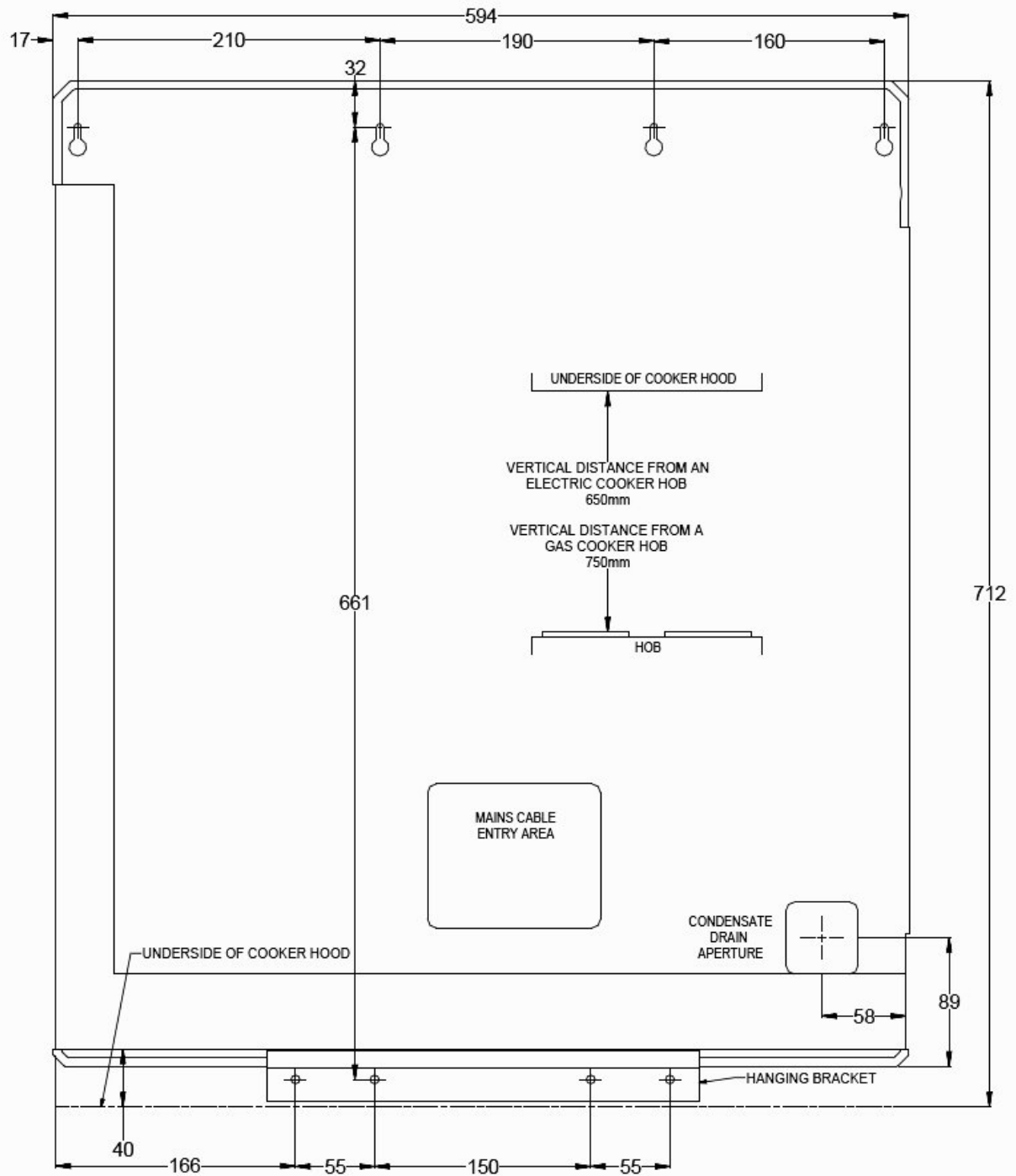

Figure 3: Sentinel Kinetic with RIGHT HAND Cooker Hood Dimensions

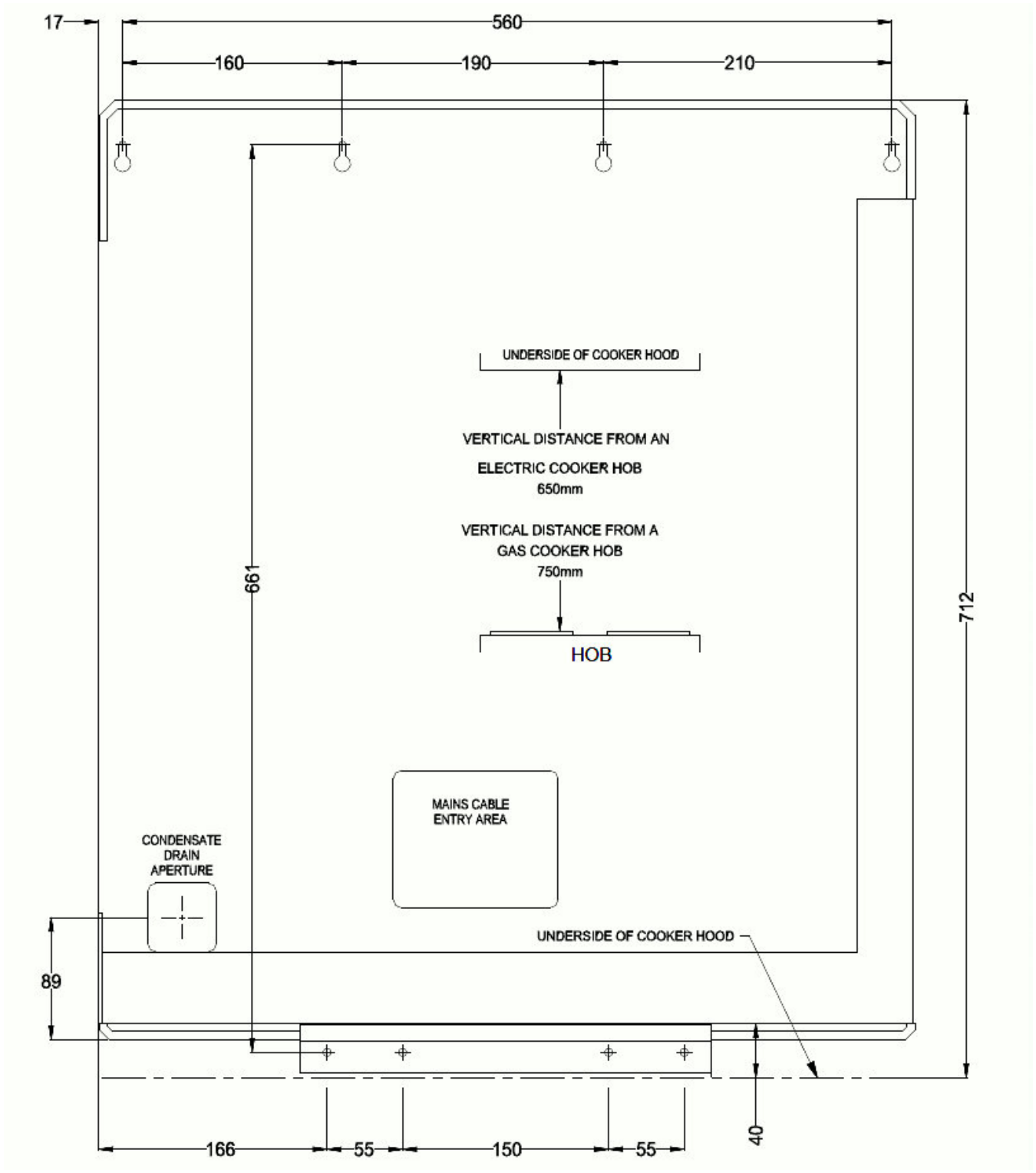

Figure 4: Sentinel Kinetic with LEFT HAND Cooker Hood Dimensions

Installation

Overview

The following instructions are intended to help prevent potential hazards and should be carried out only by a qualified electrician and installer.

Before Installing the Unit

Inspect the Unit

When taking delivery of the unit, check the items delivered against the delivery note. Inspect the unit for damage in transit. If in doubt, contact Customer Services. The Sentinel Kinetic with cooker hood is made up of two separate boxes. Each box containing the Sentinel Kinetic HR with metal duct assembly should come with an accessory pack containing wall brackets, condensate drain link pipes, worm-drive clips, fixings and product documentation. Each box containing the cooker hood should contain an accessory pack consisting of black protective box for cooker hood socket and plug connection, screws, cable receptors and product documentation. A template to aid marking out the wall for drilling is printed on the carton.

Lift and Move the Unit Safely

The weight of this unit is 28 kg. Always use appropriate lifting techniques and appliances when moving heavy equipment.

Check Site Requirements and Safety Notices

Check that the physical and environmental conditions for the site meet, or exceed, the requirements detailed in the *Technical Specification* on page 6.

Read and observe the safety notices listed in *IMPORTANT* on page 2.

Unit Installation

READ THE SENTINEL KINETIC INSTALLATION & COMMISSIONING DOCUMENT BEFORE INSTALLING THIS UNIT. In particular, ensure that any external switches, sensors and electrical connections are made prior to the unit being mounted on the wall.

The Sentinel Kinetic Cooker Hood is only suitable for installation above a domestic cooker or cooker hob. **The unit with cooker hood must be sited a minimum of 650mm above an electric hob and 750mm above a gas hob.**

It will fit in a 600 mm (external) x 300 mm deep (internal) kitchen wall cupboard space above the hob.

The wall should have sufficient strength to support the unit.

Take into consideration the position of the electrical services and the condensate drain.

Ensure there is adequate access for installation, operation and maintenance.

It is recommended that a local mains and sensor terminal connection box is installed within 1m of the unit to facilitate future maintenance, rather than wiring these directly to the unit.

The unit MUST always be mounted vertically with ducting exiting vertically. Do not use this unit as a support for any other equipment.

Select Unit Orientation

The unit may be purchased as left or right hand, where left hand refers to the connections to atmosphere being on the left side of the unit.

Condensate Horizontal Discharge Installation

To install the condensate horizontal outlet refer to Sentinel Kinetic Installation & Commissioning document page 11.

Spigot Installation

See Sentinel Kinetic Installation & Commissioning document page 13. Note, only vertical spigots can be used on this product.

Fitting the Cooker Hood to the Metal Duct Unit

1. Before fitting the unit to the wall, unpack the cooker hood, locate the four self-cutting screws and protective box for the cooker hood cable plug and socket.
2. Pull out the telescopic hood and remove the two metal filters by releasing the grey plastic springs and sliding. (fig. 5)
3. Before fixing the cooker hood to the bottom of the metal duct, take off the "L" shaped duct front cover by removing three screws.



Figure 5: Telescopic extractor hood

Fitting Cooker Hood to Right Hand Unit

Before fitting the cooker hood, you should identify whether the installed unit is Left Hand or Right Hand, see page 8.

If the unit is Left Hand, then follow instructions on page 13

1. Rest the unit on its back ready to connect the cooker hood to the bottom of metal ducting.
2. First lead the cooker hood cable through the hole at the bottom of the metal duct adaptor (fig. 6). Then align the cooker hood by choosing adjustable hole positions to suit, then fit it to the metal duct unit using four screws provided.
3. Carefully lead the cooker hood cable and plug into the metal duct and connect it with the cable with the socket ensuring that the locating lugs align. It is important that the cable is routed away from the fire damper.
4. Place the assembled socket and plug in the protective box provided shown (fig. 7). Ensure the grommet is lined up with the rib and tuck in cable assembly shown by arrow before putting the cover together. Put the boxes together and secure using the screws provided.



Figure 6: Inserting with plug through the hole



Figure 7: Telescopic extractor hood

5. Replace the "L" shaped duct front cover and tighten the three screws

Wall Mounting

6. A wall mounting template can be obtained from Vent Axia technical support or refer to pages 8 & 9 for dimensions.
7. If you are in receipt of wall mounting template, fix the template to the wall and ensure that it is level.
8. Mark the position of the condensate outlet and the four upper and four lower fixing holes.
9. See page 8 & 9. To install the condensate outlet refer to Sentinel Kinetic Installation & Commissioning document page 11.
10. Drill and plug the wall at the fixing points.
11. Locate the bottom supporting bracket provided then use four screws to fix to the wall. Ensure the angled flange is pointing towards you.
12. The upper four screws should now be fitted ready for keyhole fixing slots to engage. Leave 6 – 10 mm protruding.
13. Lift the unit and offer it to the upper screws sliding downwards, making sure that the lower part of the back plate of the unit fits into the lower supporting bracket.
14. Complete the fixing of the condensate drain as shown on page 11 of the Sentinel Kinetic manual.
15. Fix hanging brackets supplied to the front door panel, then offer it to the pre-fitted bushes. Spacers may be used to pack out the bushes to maintain the line of the cupboard doors.

Fitting Cooker Hood to Left Hand Unit

1. Remove the cooker hood light cover using cross type screwdriver.
2. After removing the light cover, turn the cooker hood to its opposite face. Unscrew the cable clip from inside, then insert the cable with its connector (fig. 8) through aperture gently by pulling it to your right as far as it will extend.
3. Feed the cable with its plug through the aperture on the right hand side (fig. 9).
4. Turn the cooker hood to its opposite face, pull the cable through as far as it extends. Use the existing cable clip and its screw to secure the cables to the hood as shown (fig. 10).
5. Now the cooker hood is ready to fit to the metal duct unit.
6. Go to instructions for Fitting Cooker Hood to Right Hand Unit, items 1-15 on pages 9 and 10.



Figure 8: Passing cable through

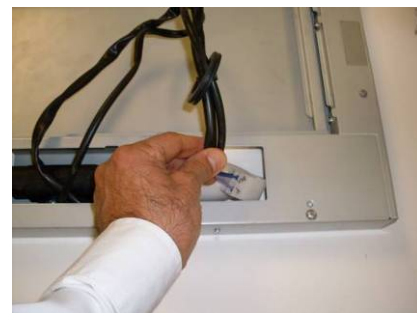

Figure 9: Insert cable opposite direction



Figure 6: Using cable clip to secure the cable

Attach Ducting

See the Sentinel Kinetic Installation & Commissioning document.

Electrical Installation

See the Sentinel Kinetic Installation & Commissioning document.

Commissioning

See the Sentinel Kinetic Installation & Commissioning document.

Setting the Cooker Hood Flow

Adjust the damper to give the correct flow as determined by the system designer.

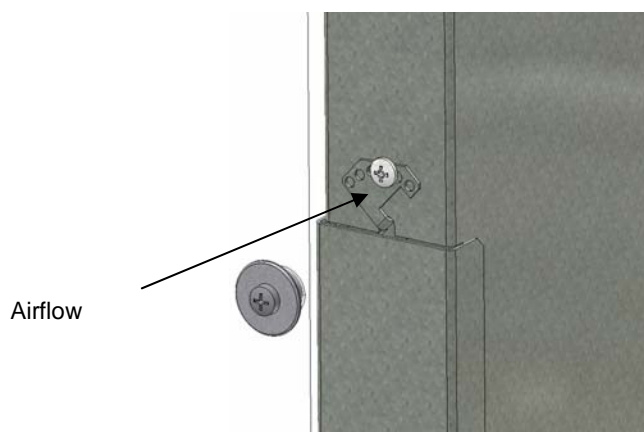

Maintenance

Caring for the Unit

Heat recovery units, by their very nature, require regular maintenance. The Sentinel Kinetic has been designed to facilitate access to enable maintenance to be carried out easily.



WARNING

THE FAN AND ANCILLARY CONTROL EQUIPMENT MUST BE ISOLATED FROM THE POWER SUPPLY DURING MAINTENANCE.

Cooker Hood Cleaning Interval

For MVHR unit maintenance, refer to Sentinel Kinetic Installation & Commissioning and Operation & Monitoring documents.

Item	Action
Cooker Hood Filters	Clean Filters every six months or more frequently if the style of cooking requires it. For instruction how to remove filters see below.
Cooker Hood Adaptor	Switch off the unit at the wall isolator before cleaning any component. Remove cover and wipe the interior clean every six months or more frequently if the style of cooking requires it. After cleaning ensure that the cover is replaced correctly and screws tightened. Do not use water or spray cleaning agents for cleaning the space, however a damp or dry cloth may be used.

Removing Filters.

- Rear Filter – To remove the rear filter grip and pull inwards the grey les at either side and slide the filter forwards and downwards.
- Front Filter – To remove the front filter grip and pull inwards the grey les at either side and drop the filters downwards.
- The filters can be washed in a dishwasher or soapy water. Thoroughly dry the filters and reassemble in reverse order.



Spares

The following spares may be ordered from Vent-Axia:

Table 1: Spares

Part No	Description
441768	Main Power Board
441767	Control Panel
441774	Filters, 2-pack (bypass version 438222)
441764	Heat Recovery Cell (bypass version 438222)
441759	Supply Motor
441760	Exhaust Motor
441776	Summer Bypass
456510	Thermal Cut-out Fuse
441542	Low Energy Bulb 11 Watt SES compact fluorescent
372777	Light Cover
372743	Cooker hood filters (set of two)

Troubleshooting

See the Sentinel Kinetic installation & commissioning documentation.

Appendix A: Options and Accessories

Humidistats

An optional internal humidistat is available as an accessory. (Part Number 441838). This adjusts the fan speed proportionally depending on the temperature and relative humidity levels in the extracted air whilst avoiding nuisance tripping at night time when temperatures drop and relative humidity naturally rises. The unit does not just look for relative humidity levels above a set point, which can be unreliable in products that extract from multiple rooms, but it also looks for a rapid increase in relative humidity typically generated by such activities as showering or cooking.

For further details on options and accessories, refer to Sentinel Kinetic installation & commissioning documentation.

Vent-Axia

Head Office: Fleming Way, Crawley, West Sussex, RH10 9YX. Tel: 01293 526062 Fax: 01293 551188

UK NATIONAL CALL CENTRE, Newton Road, Crawley, West Sussex, RH10 9JA

SALES ENQUIRIES: Tel: 0844 8560590 Fax: 01293 565169

TECHNICAL SUPPORT Tel: 0844 8560594 Fax: 01293 532814

For details of the warranty and returns procedure please refer to www.vent-axia or write to Vent-Axia Ltd, Fleming Way, Crawley, RH10 9YX